

Article

# Guest Partitioning and High CO<sub>2</sub> Selectivity in Hydroquinone Clathrates Formed from Ternary (CO + CO<sub>2</sub> + H<sub>2</sub>) Gas Mixtures

Sang Jun Yoon <sup>1</sup>, Dongwon Lee <sup>2</sup>, Ji-Ho Yoon <sup>3,\*</sup>  and Jong-Won Lee <sup>2,\*</sup><sup>1</sup> Clean Fuel Laboratory, Korea Institute of Energy Research, Daejeon 34129, Korea; yoonsj@kier.re.kr<sup>2</sup> Department of Environmental Engineering, Kongju National University, Chungnam 31080, Korea; 201502051@smail.kongju.ac.kr<sup>3</sup> Department of Energy and Resources Engineering, Korea Maritime and Ocean University, Busan 49112, Korea

\* Correspondence: jhyoon@kmou.ac.kr (J.-H.Y.); maruhill@kongju.ac.kr (J.-W.L.); Tel.: +82-51-410-4684 (J.-H.Y.); +82-41-521-9425 (J.-W.L.); Fax: +82-51-403-4680 (J.-H.Y.); +82-41-552-0380 (J.-W.L.)

Received: 24 June 2020; Accepted: 9 July 2020; Published: 12 July 2020



**Abstract:** Clathrate formation and guest behaviors in hydroquinone (HQ) clathrates were investigated for the first time using ternary (CO + CO<sub>2</sub> + H<sub>2</sub>) gas mixtures. Two gas compositions (low and high CO<sub>2</sub> concentrations) were used to simulate synthesis gases generated from various sources. After reaction at 2.0, 4.0, and 6.0 MPa, the conversion yield of pure HQ to the clathrate form reached >90% if the CO<sub>2</sub> partial pressure was 0.7 MPa or higher. In addition, CO<sub>2</sub> was the most abundant occupant, whereas CO was only detectable at higher CO concentrations and experimental pressures. The separation efficiency values expressed as molar ratios of CO<sub>2</sub> to CO in the solid clathrate form were found to be 12.7 and 23.9 MPa at 4.0 and 6.0 MPa, respectively. The experimental and the calculated results in this study provide information useful for the design of a clathrate-based separation process for synthesis gases from various sources (i.e., synthesis gases with various compositions).

**Keywords:** hydroquinone; clathrate compounds; syngas; carbon dioxide; carbon monoxide

## 1. Introduction

Carbon dioxide (CO<sub>2</sub>) separation and recovery technologies are very important for reducing CO<sub>2</sub> emissions from combustion of fossil fuels and for resolving global warming due to excess CO<sub>2</sub>. At present, CO<sub>2</sub> can be captured in two ways—by pre-combustion and post-combustion technologies [1]. The post-combustion approach removes CO<sub>2</sub> from flue gases after the fossil fuels are burned completely. In this case, the flue gases are mainly CO<sub>2</sub> + N<sub>2</sub>, except that the combustion is performed in pure oxygen. Absorption with amine solutions has been commercialized for post-combustion CO<sub>2</sub> capture [2]. Alternative technologies such as adsorption and membrane filtration are also being developed for commercial applications [2]. Meanwhile, pre-combustion CO<sub>2</sub> capture is used to remove CO<sub>2</sub> and all of the carbon content in the fossil fuels used for energy or electricity generation, because the carbon components will otherwise produce CO<sub>2</sub> after combustion. The basic idea of this de-carbonization is to convert a fossil fuel to a synthesis gas containing mostly hydrogen (H<sub>2</sub>) and CO<sub>2</sub> [3]. The synthesis gas can come from coal or oil gasification, methane reforming, or from biological waste [4]. The composition of the synthesis gas varies depending on its source, but the main components are H<sub>2</sub>, CO, and CO<sub>2</sub>. The same technologies used in post-combustion capture (adsorption, absorption, membrane) are also being developed for use in this area [5–7].

The conventional technologies face some challenges, in addition to their energy consumption and high capital cost. For example, the commercial absorption technology uses a corrosive and environmentally unfriendly absorber, while the membrane technology also has some disadvantages due to its limited thermal stability and low selectivity [8]. In this regard, the need to develop novel and low-cost technologies is increasing. One such novel technology is the use of clathrate compounds. A clathrate compound is a non-stoichiometric solid crystal formed by interactions between host and guest species [9]. Hydrogen-bonded host molecules form three-dimensional structures with cage-like cavities, which interact in ways that stabilize the entire crystal structure when a guest molecule enters a cavity. Seo et al. reported CO<sub>2</sub> removal from flue gases (post-combustion capture) by forming gas hydrate (the host material was water) [10]. In addition, some researchers also reported that CO<sub>2</sub> can be removed by forming gas hydrate from binary CO<sub>2</sub> + H<sub>2</sub> gas mixtures (pre-combustion capture) [5,7,11,12]. However, both pre- and post-combustion captures ignore the existence of carbon monoxide (CO), which occurs due to incomplete combustion or conversion of the fossil fuel. When CO adds to the binary gas mixtures (CO<sub>2</sub> + N<sub>2</sub> or CO<sub>2</sub> + H<sub>2</sub>), an additional compression process is necessary because the equilibrium condition of a CO-containing gas system shifts to a higher-pressure region [13,14]. The water–gas shift reaction is used to convert CO to CO<sub>2</sub> by supplying water vapor [4], but this additional process using a catalyst increases the total process cost. In this regard, additives such as tetrahydrofuran (THF) have been used in gas hydrate applications to reduce the formation pressure [15]. A lesser known class of semi-clathrate was used with tetra-butyl ammonium bromide (TBAB) for the same reason. Wang et al. reported that CO<sub>2</sub> can be removed from ternary mixtures of CO<sub>2</sub> + CO + H<sub>2</sub> using the semi-clathrate with TBAB [1]. This can reduce the formation (or operation) pressure to the range of 2.5–5.0 MPa, which is generally the total pressure of the synthesis gas. However, some challenges remain even when the formation pressure is lowered. To form a gas hydrate or semi-clathrate, cooling to near the freezing point is required. In addition, using an additive can result in contamination of both the solid and gas phases. Most of all, selective CO<sub>2</sub> removal by forming the hydrate once is not possible.

Forming a gas hydrate requires cooling. There are two kinds of cavities in which guest molecules can reside. However, cooling requires another type of energy consumption, leading to an additional cost, while the use of water can contaminate recovered gases due to its vapor pressure. In this regard, using an organic material that has a solid phase at room temperature and captures gaseous guests at lower pressures (approximately 0.08 MPa for CH<sub>4</sub> and CO<sub>2</sub>) could be an alternative for the hydrate-based process. Lee et al. reported on the dry synthesis of the clathrate compound using hydroquinone (HQ) as a host [16]. This organic compound is a solid crystal at room temperature and atmospheric pressure. In addition, because only one kind of cavity is formed when HQ is converted to the clathrate form, the specific gas component having the best fit can be selectively separated from the gas mixture in the solid form [8]. In our previous reports, we published work on selective separation of CO<sub>2</sub> and CO from binary CO<sub>2</sub> + H<sub>2</sub> and CO + H<sub>2</sub> gas mixtures, respectively [8,17]. Although both CO<sub>2</sub> and CO are captured in the HQ clathrates, CO<sub>2</sub> forms the clathrate compound at lower partial pressures, as indicated by spectroscopic measurements and elemental analysis results [8,18]. These gas components are the main components of synthesis gas, however the clathrate formation and guest behaviors have not been reported in gas systems, including either CO<sub>2</sub> or CO. Therefore, clathrate formation with HQ as the host was investigated in this work using ternary (CO<sub>2</sub> + CO + H<sub>2</sub>) gas mixtures at 2.0, 4.0, and 6.0 MPa. As mentioned earlier, because the composition of the synthesis gas can vary depending on its source, two gas compositions (20 and 40 mol% CO<sub>2</sub> with equimolar mixtures of CO and H<sub>2</sub>) were examined. The experimental and calculated results from this study provide very useful information on the guest behavior and component separation for the ternary gas mixtures used to simulate synthesis gas. Moreover, considering the quantitative results obtained, two potential processing concepts are proposed as well.

## 2. Materials and Methods

Pure HQ with a minimum purity of 99 mol% was supplied by Sigma-Aldrich Chemicals Co. (St. Louis, Missouri, USA). The ternary ( $\text{CO}_2 + \text{CO} + \text{H}_2$ ) gas mixtures used to simulate synthesis gases had two gas compositions: 20 mol%  $\text{CO}_2 + 40$  mol%  $\text{CO} + 40$  mol%  $\text{H}_2$  (analyzed composition of 20.1 mol%  $\text{CO}_2 + 38.8$  mol%  $\text{CO} + 41.1$  mol%  $\text{H}_2$ ) and 40 mol%  $\text{CO}_2 + 30$  mol%  $\text{CO} + 30$  mol%  $\text{H}_2$  (analyzed composition of 39.3 mol%  $\text{CO}_2 + 29.2$  mol%  $\text{CO} + 31.5$  mol%  $\text{H}_2$ ). These gases were manufactured and purchased from Daemyoung Special Gas Co. (Cheonan-si, Republic of Korea) and were used without further purification or treatment. To promote the gas-solid reaction, the HQ particles were ground into a fine powder with a particle size of less than 100  $\mu\text{m}$ . After grinding, the HQ powder was added to a high-pressure reactor (made from 316 stainless steel with an internal volume of approximately 200  $\text{cm}^3$ ) and allowed to react when pressurized at 2.0, 4.0, or 6.0 MPa with the ternary gas mixtures [8,17]. An external reservoir cell ( $\sim 500$   $\text{cm}^3$ ) was attached to the reactor to compensate the pressure drop due to clathrate formation and to keep the experimental pressure constant. Figure 1 shows a schematic diagram of the experimental instrument. After reaction for 14 days at room temperature, samples were collected for spectroscopic measurements after releasing the pressurized gas from the reactor and the reservoir. A multipurpose X-ray diffractometer (SMD 3000 model, Advanced Scientific Instrumentation Co. (Mumbai, India)) was used to identify the crystal structures of the HQ samples. The X-rays were monochromatized to a wavelength of 1.5406  $\text{\AA}$  using a parabolic mirror and channel-cut crystal [8,17]. The X-ray diffraction patterns from the HQ samples were collected from  $8.0^\circ$  to  $50.0^\circ$  with a step size of  $0.05^\circ$  and a step time of 3 s [8,17]. For solid-state  $^{13}\text{C}$  nuclear magnetic resonance (NMR), an Agilent (Santa Clara, California, USA) DD2 400 MHz spectrometer was used. The  $^{13}\text{C}$  NMR spectra were collected at ambient temperature using a 1.6 mm solid HFX fast magic angle spinning (MAS) probe at a spinning rate of 20 kHz. The pulse length of the proton was 2  $\mu\text{s}$  and a phase repetition delay of 10 s was employed with proton decoupling [8,17]. A dispersive Raman spectrometer (Horiba Jobin Yvon (Northampton, UK), Lab-RAM ARAMIS model) was used with a 460 mm focal length monochromator and an air-cooled charge-coupled device (CCD) detector. An Ar-ion laser emitting a 514 nm beam with 40 mW of power was used as the excitation source. The components of C, H, N, and S in the HQ samples were determined using an elemental analyzer (Thermo Scientific (Waltham, Massachusetts, USA), Flash 2000 Series) [8,17]. All the analytic measurements were performed immediately after pressure release and sample collection in one place (the Analysis Center for Research Advancement of Korea Advanced Institute for Science and Technology (KAIST), Republic of Korea), because the clathrate compound starts to dissociate after the release of gas from the high-pressure reactor. Basically, the experimental procedures were very similar to those described in our previous reports [8,17].

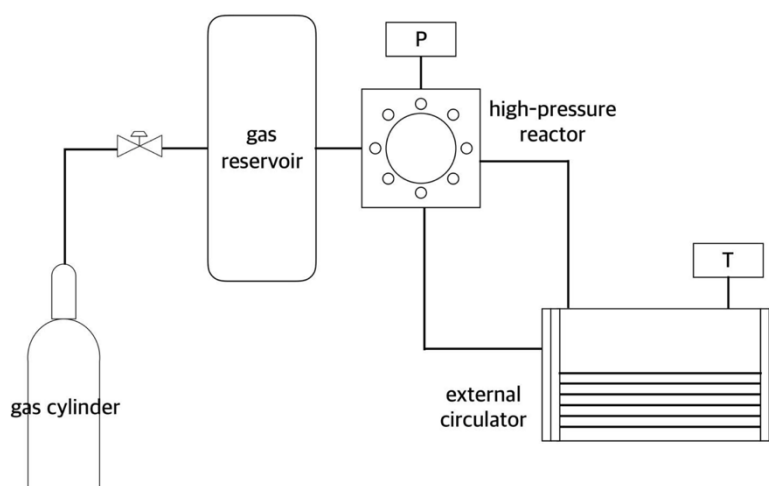
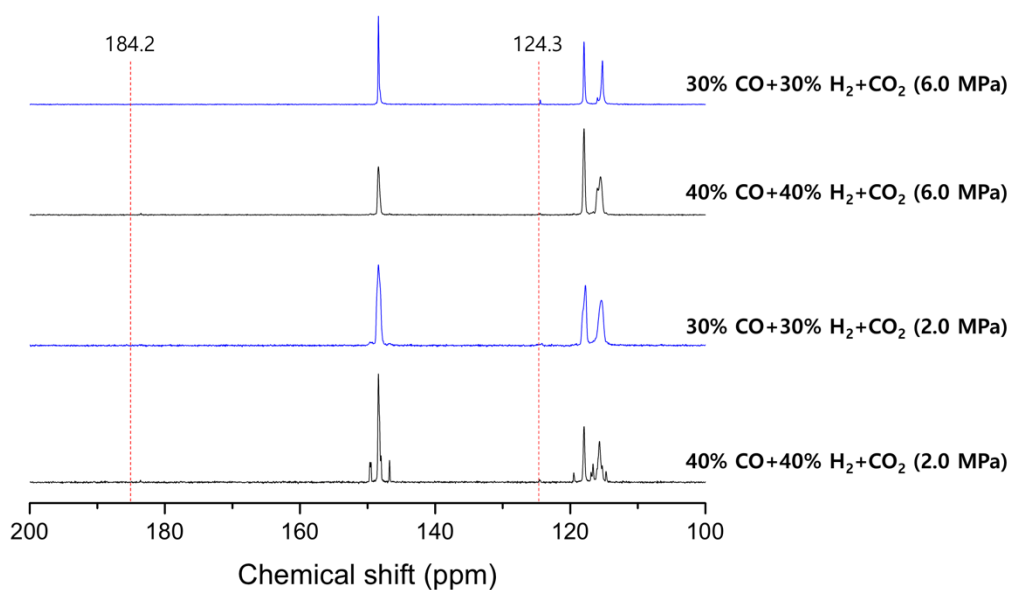

Figure 1. A schematic diagram of the experimental instrument.

### 3. Results and Discussion

In order to explore clathrate formation with the ternary ( $\text{CO}_2 + \text{CO} + \text{H}_2$ ) gas mixtures, solid-state  $^{13}\text{C}$  NMR spectra were collected for the HQ samples after the reactions. Two gas compositions (i.e., 20 mol%  $\text{CO}_2 + 40$  mol%  $\text{CO} + 40$  mol%  $\text{H}_2$ , and 40 mol%  $\text{CO}_2 + 30$  mol%  $\text{CO} + 30$  mol%  $\text{H}_2$ ) were used at the experimental pressures of 2.0 and 6.0 MPa. As shown in Figure 2, the HQ samples were not completely converted to clathrate compounds (called the  $\beta$ -forms). Pure HQ has a crystal structure called the  $\alpha$ -form, for which the NMR spectra show two groups of carbon signals (a triplet with a 2:3:1 ratio for hydroxyl-substituted carbon and an unresolved multiplet for non-substituted carbon at 116–120 ppm), as shown in the Figure 2 [8,19]. However, when HQ is converted to the  $\beta$ -form clathrate by occupation of cavities by the guest species, the triplet changes to one peak at 148 ppm, while a doublet corresponding to the non-substituted carbon signal in HQ molecules is detected at 116–120 ppm [19]. Considering such differences in the  $^{13}\text{C}$  NMR spectra, we can say that the clathrate was not formed at lower  $\text{CO}_2$  concentrations, while the conversion into the clathrate was almost complete at higher  $\text{CO}_2$  concentrations. In addition,  $\text{CO}_2$  capture can be directly observed from an additional carbon peak at 124.3 ppm, which agrees with the literature [8,18]. When the atomic signal for the hydroxyl-substituted carbon has shoulders on both sides (for example, 40 mol%  $\text{CO} + 40$  mol%  $\text{H}_2 + \text{CO}_2$  at 2.0 MPa), this means that unreacted (pure) hydroquinone is mixed with the reacted clathrate form. Because the relative intensity ratio of the triplet for pure hydroquinone is known to be 2:3:1, the middle peak area after peak deconvolution can be expressed as the sum of the pure  $\alpha$ -form and the clathrate  $\beta$ -form signals. The percentage value for this  $\beta$ -form signal can be interpreted as a conversion yield to the clathrate compound [17,19]. The obtained conversion yields were 57.40% for the 20 mol%  $\text{CO}_2$ -containing gas mixtures and 96.16% for 40 mol%  $\text{CO}_2$ -containing gas mixtures.



**Figure 2.** Solid-state  $^{13}\text{C}$  NMR spectra for hydroquinone (HQ) samples after reaction with ternary ( $\text{CO}_2 + \text{CO} + \text{H}_2$ ) gas mixtures at 2.0 and 6.0 MPa. Blue plots represent HQ samples after reaction with the ternary (30%  $\text{CO} + 30\%$   $\text{H}_2 + 40\%$   $\text{CO}_2$ ) gas, while black ones represent HQ samples after reaction with the ternary (40%  $\text{CO} + 40\%$   $\text{H}_2 + 20\%$   $\text{CO}_2$ ) gas. Dashed lines at 184.2 and 124.3 ppm represent the chemical shifts from  $\text{CO}$  and  $\text{CO}_2$  molecules captured in the clathrate cages, respectively.

When the experimental pressure was increased to 6.0 MPa, HQ showed complete conversion to the clathrate form, regardless of the  $\text{CO}_2$  concentration in the gas phase. Guest  $\text{CO}_2$  was also observed in all the HQ samples prepared. No additional peak was detected at 184.2 ppm, where a carbon signal from  $\text{CO}$  molecules was reported to occur [17]. However, it should be noted that the signal of the right peak was split for the non-substituted carbon. This is thought to mean that two kinds of HQ

clathrates (i.e., CO- and CO<sub>2</sub>-loaded clathrates) co-existed. The difference between the two signals for the non-substituted carbon atom in the HQ molecule is known to vary depending on the guest nature and the cage occupancy [8]. For CO-occupied clathrate, the difference was reported to be 1.80 ppm, while the value reported for the CO<sub>2</sub>-occupied clathrate was 2.59 ppm [8,17]. Therefore, the existence of the middle peak among the non-substituted carbon signals indicates that the CO guest clathrate was formed. The proportion of the CO guest clathrate was calculated using numerical integration and was found to be 28.48% (that is, 71.52% was CO<sub>2</sub> guest clathrate) for the 20 mol% CO<sub>2</sub>-containing gas mixture, while it was 1.47% (98.53% of CO<sub>2</sub>-occupied clathrate) for the 40 mol% CO<sub>2</sub>-containing gas mixture. A larger proportion can be obtained for ternary gas mixtures with higher CO concentrations, but CO<sub>2</sub> is more readily retained in the HQ clathrate than CO molecules are. No additional peak was detected at 184.2 ppm, even though there were split carbon signals for the non-substituted carbon in the HQ molecule [17]. This means there were some empty (guest-free) CO guest clathrates. Rapid release of CO from some cavities while collecting samples, along with the non-stoichiometric characteristics of the clathrate compound, are thought to contribute to such empty clathrate cavities. Such empty  $\beta$ -form clathrate cavities have also been reported in the literature [20,21].

To identify guest molecules and the formation of the HQ clathrate, Raman spectroscopy was performed for the prepared HQ samples. The Raman spectra in Figure 3 agree well with the Raman pattern reported for pure HQ and for the HQ clathrate [22]. In other words, among the three peaks for the C–C stretching mode at 1600–1620 cm<sup>-1</sup>, the middle one is the largest for pure unreacted HQ, while it is the smallest when HQ is converted into the  $\beta$ -form clathrate [22]. In addition, the C–H stretching mode at 3000–3070 cm<sup>-1</sup> obtained for the HQ sample prepared with 20 mol% CO<sub>2</sub>-containing gas at 2.0 MPa was different from the others [22]. This difference meant that the HQ sample remained unreacted, while the other samples were predominantly  $\beta$ -form, supporting the NMR results. In addition, the C–O stretching mode for CO<sub>2</sub> molecules was observed for all the samples, which is direct evidence for the presence of CO<sub>2</sub> in the clathrate cages [8,18]. For the HQ sample prepared with the 20 mol% CO<sub>2</sub>-containing gas mixture at 6.0 MPa, the C–O stretching mode for CO molecules was observed at 2137 cm<sup>-1</sup> [17]. Combining all the above information indicates that larger amounts (spectroscopically detectable amounts) of CO<sub>2</sub> occupied the HQ clathrates, while few CO molecules were found in the clathrate, except at the highest CO partial pressure (i.e., 20 mol% CO<sub>2</sub>-containing gas mixture at 6.0 MPa). It should be noted that some clathrate cavities remained empty even though some CO guest clathrate formed. It has been reported that H<sub>2</sub> is not retained in the clathrate form [8,17], so it was not surprising that no experimental observations of H<sub>2</sub> retention were obtained in this study. Therefore, it can be said that even if ternary (CO<sub>2</sub> + CO + H<sub>2</sub>) gas mixtures are used, only CO and CO<sub>2</sub> molecules compete for partitioning within the solid clathrate, while H<sub>2</sub> molecules are excluded. Moreover, CO<sub>2</sub> molecules are more likely to occupy cavities than CO molecules are.

X-ray diffraction (XRD) measurements were also performed in order to identify the crystal structures of the prepared HQ samples (Figure 4). Pure HQ and the  $\beta$ -form clathrate show little difference in their crystal structures (space group), except for the molecular alignment of the  $\beta$ -form and lattice parameters [8]. The obtained diffraction patterns correspond to the  $\beta$ -form with conversion to the HQ clathrate (except for the HQ sample prepared with the 20 mol% CO<sub>2</sub>-containing gas mixture at 2.0 MPa). The lattice parameters calculated from the diffraction patterns were found to be  $a = 38.5216 \pm 0.0086 \text{ \AA}$  and  $c = 5.6531 \pm 0.0006 \text{ \AA}$  ( $\alpha$ -form), and  $a = 16.5200 \pm 0.0349 \text{ \AA}$  and  $c = 5.7000 \pm 0.0034 \text{ \AA}$  ( $\beta$ -form) for the 20 mol% and 40 mol% CO<sub>2</sub>-containing gas mixtures, respectively, at 2.0 MPa. These values agree well those reported in the literature [16–18]. In addition, when the experimental pressure was increased to 6.0 MPa, the lattice parameters for 20 mol% and 40 mol% CO<sub>2</sub>-containing gas mixtures were found to be  $a = 16.4838 \pm 0.0082 \text{ \AA}$  and  $c = 5.6981 \pm 0.0017 \text{ \AA}$ , and  $a = 16.3878 \pm 0.0221 \text{ \AA}$  and  $c = 5.7440 \pm 0.0061 \text{ \AA}$ , respectively. These changes in the crystal structures agree with previous spectroscopic measurements [8,17,18].

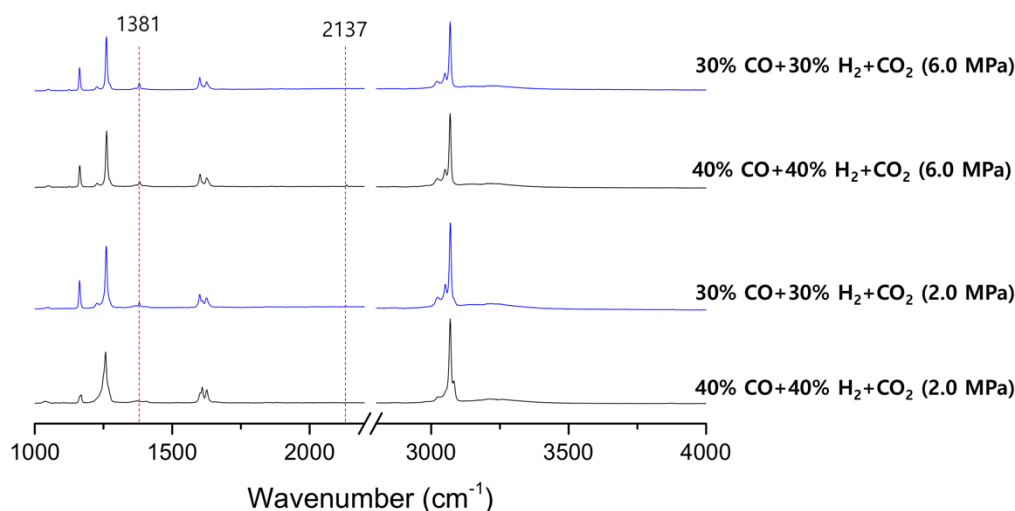

**Figure 3.** Raman spectra for hydroquinone (HQ) samples after reaction with ternary ( $\text{CO}_2 + \text{CO} + \text{H}_2$ ) gas mixtures at 2.0 and 6.0 MPa. Blue plots represent HQ samples after reaction with the ternary (30%  $\text{CO} + 30\% \text{H}_2 + 40\% \text{CO}_2$ ) gas, while black ones represent HQ samples after reaction with the ternary (40%  $\text{CO} + 40\% \text{H}_2 + 20\% \text{CO}_2$ ) gas. Dashed lines at  $2137 \text{ cm}^{-1}$  and  $1381 \text{ cm}^{-1}$  indicate the stretching mode for C–O bonds of CO and  $\text{CO}_2$  molecules trapped in the clathrate cages, respectively.

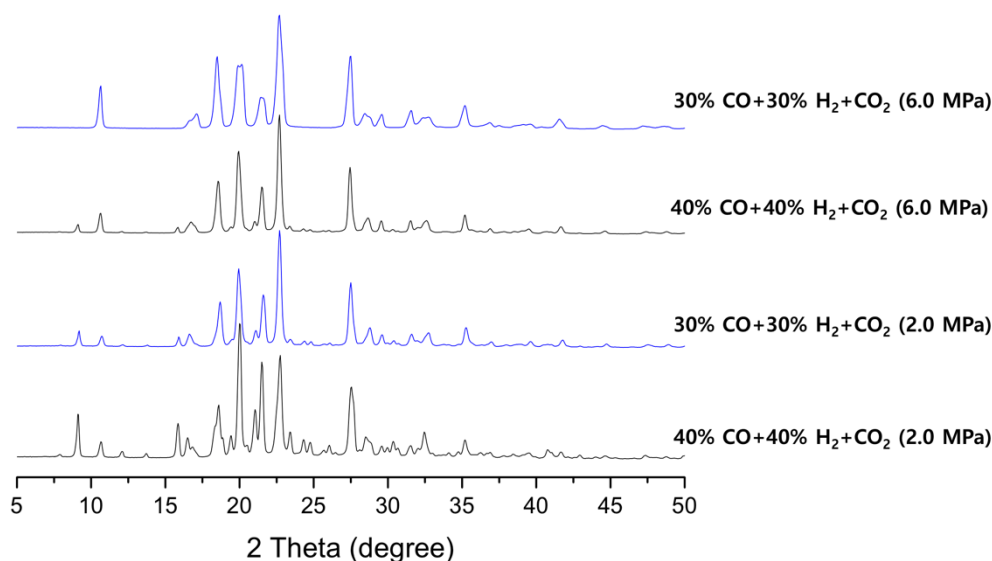

**Figure 4.** X-ray diffraction (XRD) patterns for hydroquinone (HQ) samples after reaction with ternary ( $\text{CO}_2 + \text{CO} + \text{H}_2$ ) gas mixtures at 2.0 and 6.0 MPa. Blue plots represent HQ samples after reaction with the ternary (30%  $\text{CO} + 30\% \text{H}_2 + 40\% \text{CO}_2$ ) gas, while black ones represent HQ samples after reaction with the ternary (40%  $\text{CO} + 40\% \text{H}_2 + 20\% \text{CO}_2$ ) gas.

For detailed information on the guest molecules in the HQ clathrates, elemental analysis for C, H, N, S, and O was also performed. After combining the results of elemental analysis with numerical integration for the NMR spectrum peaks, conversion yields to the HQ clathrate, in addition to the guest (CO and  $\text{CO}_2$ ) occupancies, were calculated (Figure 5 and Table 1). The samples were prepared at three experimental pressures of 2.0, 4.0, and 6.0 MPa with ternary ( $\text{CO}_2 + \text{CO} + \text{H}_2$ ) gas mixtures of two compositions. To more easily identify the  $\text{CO}_2$  separation trends, the results were plotted with regard to the simplified partial  $\text{CO}_2$  pressure ( $y_{\text{CO}_2} \times P_{\text{total}}$ ). As can be seen in the graph, the conversion yield reaches  $>90\%$  if the  $\text{CO}_2$  partial pressure is 0.7 MPa, while complete conversion is observed for the HQ samples if the  $\text{CO}_2$  partial pressure is  $>0.7$  MPa. In addition, most of the cavity content is  $\text{CO}_2$ , while CO is only detectable at higher CO concentrations and experimental pressures (that

is, with the 40 mol% CO-containing gas mixtures at 4.0 and 6.0 MPa). The ideal formula of the HQ clathrate is expressed as  $3\text{HQ}\cdot x\text{Gas}$ , where the cage occupancy (defined as the value of  $x$ ) can have any value from 0 to 1 due to the compound's non-stoichiometric property [8]; that is, the cage occupancy 0 means that all the cages of the clathrate form are completely empty, while the value of 1 indicates that all of the cages are occupied by the guest molecules. The cage occupancy rates by  $\text{CO}_2$  molecules obtained in this study were found to be 10–30% (corresponding to 0.09–6.8 L  $\text{CO}_2$  (STP)/kg of HQ). Meanwhile, cage occupancy rates by CO were just 0.7 and 0.9 % at 4.0 and 6.0 MPa (the highest CO partial pressures), respectively. Therefore, a significant number of clathrate cavities remained empty, even though the HQ molecules were converted to the clathrate form. The mole ratios of  $\text{CO}_2$  to CO values in the solid clathrate were found to be 12.7 and 23.9 at 4.0 and 6.0 MPa, respectively. In other words, ten times more  $\text{CO}_2$  could be encapsulated in the solid clathrate, even if the  $\text{CO}_2$  concentration was slightly larger or smaller than the CO concentration. The molar ratios are infinity for the other HQ samples because no CO molecules were found in the clathrate.

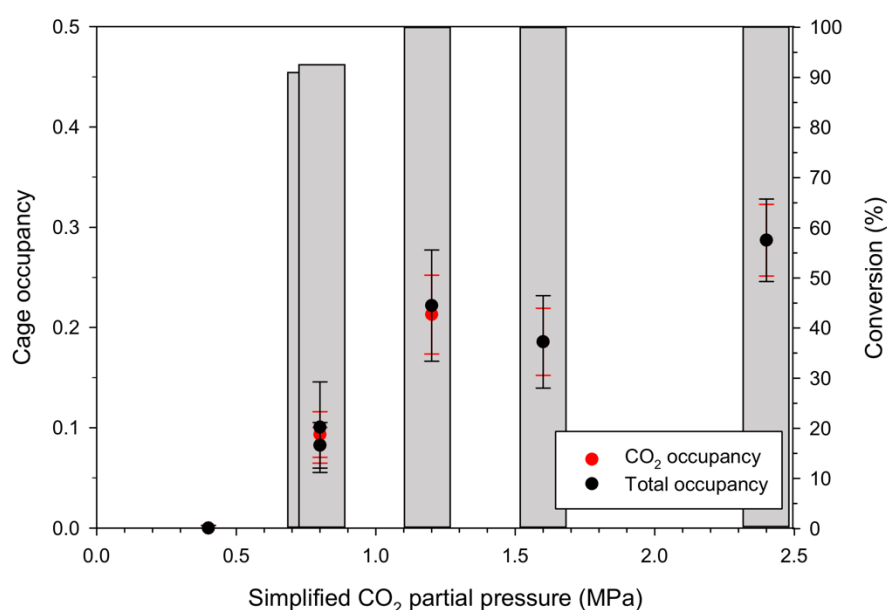

**Figure 5.** Cage occupancies of  $\text{CO}_2$  and ( $\text{CO}_2 + \text{CO}$ ) total molecules in the hydroquinone (HQ) clathrate cages, which are expressed regarding the simplified  $\text{CO}_2$  partial pressures. Conversion yields of HQ to the clathrate form are displayed in the bar graph, with corresponding values shown in the right axis.

**Table 1.** Cage occupancies of enclathrated guest molecules in the hydroquinone (HQ) clathrate cages and conversion yields of HQ to the clathrate form.

Simplified $\text{CO}_2$ Partial Pressure (MPa)	Guest Occupancies			Conversion Yield (%)
	$\text{CO}_2$	CO	Total	
0.4	0.0000 ± 0.0003	0.0000 ± 0.0001	0.0000 ± 0.0003	0.0
0.8	0.0932 ± 0.0227	0.0073 ± 0.0225	0.1005 ± 0.0452	91.1
0.8	0.0825 ± 0.0177	0.0000 ± 0.0050	0.0825 ± 0.0227	92.4
1.2	0.2129 ± 0.0394	0.0089 ± 0.0161	0.2218 ± 0.0555	100.0
1.6	0.1857 ± 0.0334	0.0000 ± 0.0128	0.1857 ± 0.0462	100.0
2.4	0.2871 ± 0.0357	0.0000 ± 0.0054	0.2871 ± 0.0411	100.0

Based upon these experimental and calculated results, we propose two processes for clathrate-based  $\text{CO}_2$  separation (Figure 6). The first process could be applied to synthesis gases at relatively high pressures and high CO concentrations. In this process, a reactor (reactor 1 in the figure) is used to separate both CO and  $\text{CO}_2$  from the gas mixtures. Thus, only hydrogen comes out of the reactor. The clathrate compounds from reactor 1 are then allowed to dissociate and release all of the captured

gas components. Then, pure CO<sub>2</sub> can be separated by forming HQ clathrate using the released CO<sub>2</sub> + CO gas mixtures at lower pressure. The second process would be used for more typical synthesis gases. The first reactor would be used to capture pure (or almost pure) CO<sub>2</sub> by forming HQ clathrate. Next, the exhausted gas would be compressed, then enter a second reactor to separate CO from H<sub>2</sub>. According to the experimental and calculated results, the latter process seems to be more viable. As mentioned before, the HQ clathrates ( $\beta$ -form) can be formed with empty cavities, which can be used to capture guest species more readily [21,23]. Therefore, it may be possible to reduce the operational cost and to decrease the clathrate formation time by recycling the HQ clathrate after dissociation. Although guest behaviors and the formation of empty clathrate cavities were identified and two concepts for clathrate-based gas-separation processes were proposed, additional large-scale investigation will be necessary to design a practical process.

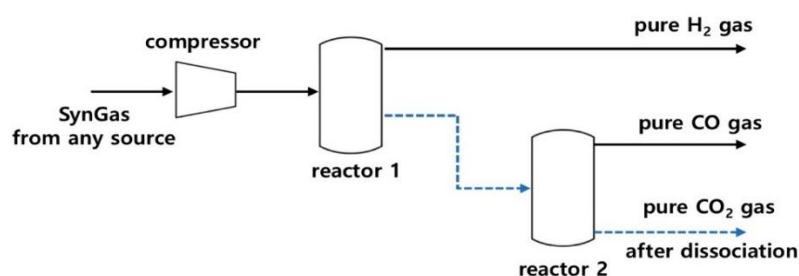

(a)

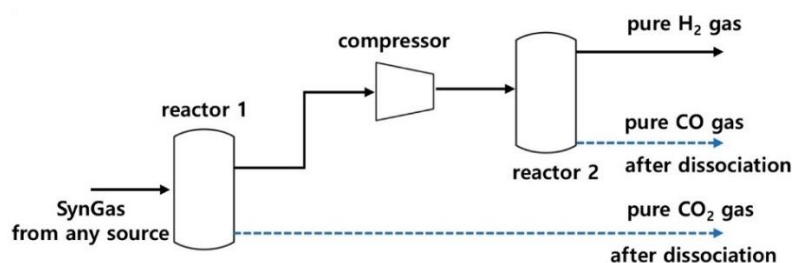

(b)

**Figure 6.** Two conceptual clathrate-based processes for CO<sub>2</sub> separation of synthesis gases from a variety of sources: (a) A clathrate-based process for separating H<sub>2</sub> from the first reactor, then separating CO<sub>2</sub> at the second reactor; (b) In this process, CO<sub>2</sub> is separated first, then the remaining gas mixture is compressed and reacted to separate CO in the clathrate form from gaseous H<sub>2</sub>. Dotted blue lines indicate the flow of the solid clathrate compounds in the process. By recycling empty (guest-free) or degassed hydroquinone clathrates after dissociation to remove enclathrated gases, the processing time might be shortened.

#### 4. Conclusions

The HQ clathrate formation was verified using ternary (CO<sub>2</sub> + CO + H<sub>2</sub>) gas mixtures with two compositions: 20 mol% CO<sub>2</sub> + 40 mol% CO + 40 mol% H<sub>2</sub> and 40 mol% CO<sub>2</sub> + 30 mol% CO + 30 mol% H<sub>2</sub>. Although HQ molecules were almost fully converted to the clathrate form (except for some at lower pressures), most of the clathrate cavities were found to be occupied by CO<sub>2</sub> molecules rather



than CO (>10 times). The proportion of CO guest clathrate calculated using numerical integration was 28.48% (that is, 71.52% of CO<sub>2</sub> guest clathrate) for the 20 mol% CO<sub>2</sub>-containing gas mixture, while it was 1.47% (98.53% of CO<sub>2</sub>-occupied clathrate) for the 40 mol% CO<sub>2</sub>-containing gas mixture. However, CO cage occupancies were just 0.7% and 0.9% at 4.0 and 6.0 MPa (the highest CO partial pressures), respectively, which were much lower than the CO clathrate proportions. Such differences indicate that there were some empty cavities in the clathrate structures. In addition, the conversion yields of HQ to clathrate was found to be 90% or more if the CO<sub>2</sub> partial pressure was 0.7 MPa or higher. Such complete conversion at lower CO<sub>2</sub> partial pressures and the higher probability of finding CO<sub>2</sub> in the clathrate cages led us to propose two concepts for clathrate-based separation of synthesis gases from a variety of sources.

**Author Contributions:** Conceptualization, S.J.Y. and J.-W.L.; methodology, J.-W.L.; validation, S.J.Y. and J.-W.L.; investigation, D.L.; resources, D.L.; data curation, J.-W.L.; writing—original draft preparation, S.J.Y. and J.-W.L.; writing—review and editing, S.J.Y. and J.-H.Y.; supervision, J.-W.L.; All authors have read and agreed to the published version of the manuscript.

**Funding:** This research received no external funding.

**Acknowledgments:** This research was financially supported by Basic Science Research Program through the National Research Foundation of Korea (NRF), funded by the Ministry of Education (NRF-2018R1A2B6009170), and also supported by Korea Ministry of Environment (MOE) as the Waste to Energy Recycling Human Resource Development Project.

**Conflicts of Interest:** The authors declare no conflict of interest.

## References

1. Wang, S.; Danner, M.; Kuchling, T.; Clarke, M.A. Measurement of the three-phase (vapour+liquid+solid) equilibrium conditions of semi-clathrates formed from mixtures of CO<sub>2</sub>, CO and H<sub>2</sub>. *J. Chem. Thermodyn.* **2013**, *56*, 149–152. [[CrossRef](#)]
2. Yang, H.; Xu, Z.; Fan, M.; Gupta, R.; Slimane, R.B.; Bland, A.E.; Wright, I. Progress in carbon dioxide separation and capture: A review. *J. Environ. Sci.* **2008**, *20*, 14–27. [[CrossRef](#)]
3. Kim, S.M.; Lee, J.D.; Lee, H.J.; Lee, E.K.; Kim, Y. Gas hydrate formation method to capture the carbon dioxide for pre-combustion process in igcc plant. *Int. J. Hydrog. Energ.* **2011**, *36*, 1115–1121. [[CrossRef](#)]
4. Srinivas, S.; Malik, R.K.; Mahajani, S.M. Fischer-Tropsch synthesis using bio-syngas and CO<sub>2</sub>. *Energy Sustain. Dev.* **2007**, *11*, 66–71. [[CrossRef](#)]
5. Babarao, R.; Eddaoudi, M.; Jiang, J.W. Highly porous ionic rht metal-organic framework for H<sub>2</sub> and CO<sub>2</sub> storage and separation: A molecular simulation study. *Langmuir* **2010**, *26*, 11196–11203. [[CrossRef](#)] [[PubMed](#)]
6. Franz, J.; Scherer, V. An evaluation of CO<sub>2</sub> and H<sub>2</sub> selective polymeric membranes for CO<sub>2</sub> separation in igcc processes. *J. Membr. Sci.* **2010**, *359*, 173–183. [[CrossRef](#)]
7. Korelskiy, D.; Ye, P.; Fouladvand, S.; Karimi, S.; Sjoberg, E.; Hedlund, J. Efficient ceramic zeolite membranes for CO<sub>2</sub>/H<sub>2</sub> separation. *J. Mater. Chem. A* **2015**, *3*, 12500–12506. [[CrossRef](#)]
8. Lee, J.-W.; Poudel, J.; Cha, M.; Yoon, S.J.; Yoon, J.-H. Highly selective CO<sub>2</sub> extraction from a mixture of CO<sub>2</sub> and H<sub>2</sub> gases using hydroquinone clathrates. *Energy Fuels* **2016**, *30*, 7604–7609. [[CrossRef](#)]
9. Atwood, J.L.; Davies, J.E.D.; MacNicol, D.D. *Inclusion Compounds*; Academic Press: Orlando, FL, USA, 1984; Volume 1.
10. Seo, Y.-T.; Kang, S.-P.; Lee, H.; Lee, C.-S.; Sung, W.-M. Hydrate phase equilibria for gas mixtures containing carbon dioxide: A proof-of-concept to carbon dioxide recovery from multicomponent gas stream. *Korean J. Chem. Eng.* **2000**, *17*, 659–667. [[CrossRef](#)]
11. Lee, J.-W.; Yoon, J.-H. Preferential occupation of CO<sub>2</sub> molecules in hydroquinone clathrates formed from CO<sub>2</sub>/N<sub>2</sub> gas mixtures. *J. Phys. Chem. C* **2011**, *115*, 22647–22651. [[CrossRef](#)]
12. Zhang, L.; Hu, Z.; Jiang, J. Metal-organic framework/polymer mixed-matrix membranes for H<sub>2</sub>/CO<sub>2</sub> separation: A fully atomistic simulation study. *J. Phys. Chem. C* **2012**, *116*, 19268–19277. [[CrossRef](#)]
13. Davidson, D.W.; Desando, M.A.; Gough, S.R.; Handa, Y.P.; Ratcliffe, C.I.; Ripmeester, J.A.; Tse, J.S. A clathrate hydrate of carbon monoxide. *Nature* **1987**, *323*, 418–419. [[CrossRef](#)]

14. Mohammadi, A.H.; Anderson, R.; Tohidi, B. Carbon monoxide clathrate hydrates: Equilibrium data and thermodynamic modeling. *AIChE J.* **2005**, *51*, 2825–2833. [[CrossRef](#)]
15. Kang, S.-P.; Lee, H. Recovery of CO<sub>2</sub> from flue gas using gas hydrate: Thermodynamic verification through phase equilibrium measurements. *Environ. Sci. Technol.* **2000**, *34*, 4397–4400. [[CrossRef](#)]
16. Lee, J.-W.; Lee, Y.; Takeya, S.; Kawamura, T.; Yamamoto, Y.; Lee, Y.-J.; Yoon, J.-H. Gas-phase synthesis and characterization of CH<sub>4</sub>-loaded hydroquinone clathrates. *J. Phys. Chem. B* **2010**, *114*, 3254–3258. [[CrossRef](#)] [[PubMed](#)]
17. Lee, J.-W.; Lee, S.H.; Yoon, S.J.; Yoon, J.-H. Spectroscopic studies on the formation and guest behaviors of hydroquinone clathrate with binary CO and H<sub>2</sub> gas mixtures. *Energy Fuels* **2018**, *32*, 6863–6868. [[CrossRef](#)]
18. Lee, J.-W.; Choi, K.J.; Lee, Y.; Yoon, J.-H. Spectroscopic identification and conversion rate of gaseous guest-loaded hydroquinone clathrates. *Chem. Phys. Lett.* **2012**, *528*, 34–38. [[CrossRef](#)]
19. Ripmeester, J.A. Application of solid state <sup>13</sup>C NMR to the study of polymorphs, clathrates and complexes. *Chem. Phys. Lett.* **1980**, *74*, 536–538. [[CrossRef](#)]
20. Lee, Y.-J.; Han, K.W.; Jang, J.S.; Jeon, T.-I.; Park, J.; Kawamura, T.; Yamamoto, Y.; Sugahara, T.; Vogt, T.; Lee, J.-W.; et al. Selective CO<sub>2</sub> trapping in guest-free hydroquinone clathrate prepared by gas-phase synthesis. *Chem. Phys. Chem.* **2011**, *12*, 1056–1059. [[CrossRef](#)]
21. Coupan, R.; Chabod, M.; Dicharry, C.; Diaz, J.; Miqueu, C.; Torr , J.-P. Characterization study of CO<sub>2</sub>, CH<sub>4</sub>, and CO<sub>2</sub>/CH<sub>4</sub> hydroquinone clathrates formed by gas-solid reaction. *J. Phys. Chem. C* **2017**, *121*, 22883–22894. [[CrossRef](#)]
22. Kubinyi, M.; Billes, F.; Grofcsik, A.; Keresztury, G. Vibrational spectra and normal coordinate analysis of phenol and hydroquinone. *J. Mol. Struct.* **1992**, *266*, 339–344. [[CrossRef](#)]
23. Coupan, R.; P r , E.; Dicharry, C.; Torr , J.-P. New insights on gas hydroquinone clathrates using in situ raman spectroscopy: Formation/dissociation mechanisms, kinetics, and capture selectivity. *J. Phys. Chem. A* **2017**, *121*, 5450–5458. [[CrossRef](#)] [[PubMed](#)]



  2020 by the authors. Licensee MDPI, Basel, Switzerland. This article is an open access article distributed under the terms and conditions of the Creative Commons Attribution (CC BY) license (<http://creativecommons.org/licenses/by/4.0/>).