



## Article

# Solid Oxide Fuel Cell-Based Polygeneration Systems in Residential Applications: A Review of Technology, Energy Planning and Guidelines for Optimizing the Design

Farah Ramadhani <sup>1,\*</sup> , M. A. Hussain <sup>2,\*</sup>, Hazlie Mokhlis <sup>3,\*</sup>  and Oon Erixno <sup>4</sup> <sup>1</sup> Physics Department, Faculty of Science, University of Malaya, Kuala Lumpur 50603, Malaysia<sup>2</sup> Chemical Engineering Department, Faculty of Engineering, University of Malaya, Kuala Lumpur 50603, Malaysia<sup>3</sup> Electrical Engineering Department, Faculty of Engineering, University of Malaya, Kuala Lumpur 50603, Malaysia<sup>4</sup> Higher Institution Centre of Excellence (HICoE), UM Power Energy Dedicated Advanced Centre (UMPEDAC), Level 4, Wisma R&D Universiti Malaya, Jalan Pantai Baharu, Kuala Lumpur 59990, Malaysia

\* Correspondence: farahr@um.edu.my (F.R.); mohd\_azlan@um.edu.my (M.A.H.); hazli@um.edu.my (H.M.)

**Abstract:** Solid oxide fuel cells are an emerging energy conversion technology suitable for high-temperature power generation with proper auxiliary heat. Combining SOFCs and polygeneration has produced practical applications for modern energy system designs. Even though many researchers have reviewed these systems' technologies, opportunities and challenges, reviews regarding the optimal strategy for designing and operating the systems are limited. Polygeneration is more complicated than any other energy generation type due to its ability to generate many types of energy from various prime movers. Moreover, integration with other applications, such as vehicle charging and fueling stations, increases the complication in making the system optimally serve the loads. This study elaborates on the energy planning and guidelines for designing a polygeneration system, especially for residential applications. The review of polygeneration technologies also aligns with the current research trend of developing green technology for modern and smart homes in residential areas. The proposed guideline is expected to solve the complication in other applications and technologies and design the polygeneration system optimally.

**Keywords:** polygeneration; SOFC; optimal design; residential; electric vehicles; hydrogen vehicle



**Citation:** Ramadhani, F.; Hussain, M.A.; Mokhlis, H.; Erixno, O. Solid Oxide Fuel Cell-Based Polygeneration Systems in Residential Applications: A Review of Technology, Energy Planning and Guidelines for Optimizing the Design. *Processes* **2022**, *10*, 2126. <https://doi.org/10.3390/pr10102126>

Academic Editors: Pei Liu, Ming Liu and Xiao Wu

Received: 22 September 2022

Accepted: 17 October 2022

Published: 19 October 2022

**Publisher's Note:** MDPI stays neutral with regard to jurisdictional claims in published maps and institutional affiliations.



**Copyright:** © 2022 by the authors. Licensee MDPI, Basel, Switzerland. This article is an open access article distributed under the terms and conditions of the Creative Commons Attribution (CC BY) license (<https://creativecommons.org/licenses/by/4.0/>).

## 1. Introduction

The increase in energy demand has triggered the development and exploration of various types of energy supply. One of the recent developments in energy supply is polygeneration. Polygeneration is an energy generation system that can provide three or more energy types by integrating one or two prime movers. The kinds of energy generation and prime mover sometimes relate to applying polygeneration and available sources. Rapid developments of renewable energy sources have also affected the excitement surrounding the use of polygeneration to tackle climate change and neutralize carbon emissions from non-renewable-based energy generation [1].

The increased attention regarding polygeneration systems resonates with the fact that people need various energy types in one integrated system. The rapidness of technology is a significant reason for the variety of energy required by people. Currently, the needs are increasing and are not limited to electric consumption but also include the need for heating, water cooling and clean water, clean air and green fuels. The ineffectiveness of separated systems related to their efficiency and fuel consumption is another issue that increases the implementation of the polygeneration system [2]. In the separation concept, only one primary source can generate energy with single conversion efficiency and much

waste. However, a polygeneration system works with the waste and converts it to become a useful side product that increases the conversion efficiency. In line with that, a split system is much more costly than polygeneration in terms of energy cost. The increase in fuel price must be a consideration when increasing the effectiveness of an energy generation system to have lower energy costs and affordable operation costs.

Solid oxide fuel cells (SOFCs) are attractive as fuel cells in stationary applications such as polygeneration systems. Their high-temperature characteristic is valuable for heating and cooling generation. When a SOFC is combined with a solid oxide electrolyzer cell (SOEC) or works with hydrogen fuel, it becomes a carbon-neutralized system that can produce various energy types and fuels. SOFC-based polygeneration systems have become widely used for industrial, public and private applications such as those in residential areas [3,4].

Despite the effectiveness of polygeneration, the drawbacks of implementing the system are still challenging. Due to the various sources and products generated, the biggest challenge is designing an effective polygeneration system. Creating a polygeneration system does not mean combining two or more primary sources to have three or more products. With ineffective design, a polygeneration system might have less efficiency and a higher energy cost than a separated system. Moreover, when optimizing the system design, more than one aim might need to be considered, making the system more complicated to develop. Therefore, optimization and management are needed when designing a polygeneration system starting with synthesizing the sources and components, sizing the capacity and operating the system depending on the schedule, use or achievement objectives.

In the literature, polygeneration systems and fuel cells are topics that have been receiving attention since the beginning of this decade. Many fuel-cell-based polygeneration system concepts have been reviewed for various applications, such as desalination [3,5–7], industries [8], public services [9] and community-based power generation [10]. Among the reviewed literature, the prospect of polygeneration and its challenges are discussed quite prevalently [10–12]. Other studies about the state of the art and technology reviews of polygeneration systems were discussed in refs. [13–15]. However, none of the review papers focused on the optimal development and preparation of polygeneration system design. Even though the design is the first step in developing a system, there is an urgent need to discuss the topic and give insight into how to design a polygeneration system, especially when using fuel cells as the prime mover.

This research aims to review polygeneration technologies and propose a guideline for performing energy planning and optimizing the system. This work has continuity with the previous review paper [16], which concerned cogeneration systems. However, polygeneration systems have advanced purposes and complicated designs compared to cogeneration systems, making the procedure more challenging. Therefore, with the energy planning and guideline proposed, it is expected that researchers can gain insight when developing a polygeneration system. On top of that, this work could be a guideline for various applications of a polygeneration system with various primary energy sources, products and objectives.

This paper consists of a brief description of energy design in residential applications in Section 2, continuing with a general presentation on energy system designs in Section 3. Section 4 explains the overview of polygeneration systems, while Section 5 discusses SOFC-based polygeneration system applications. Section 6 presents the energy planning for designing a polygeneration system, while Section 7 explains the guideline for optimizing polygeneration system design.

## 2. The Evolution of Residential Energy Supply Designs

Residential areas are among those with high energy use, which raises global greenhouse gas (GHG) emissions. The production of residential buildings accounts for more than 40% of power and 21% of GHG emissions [17]. According to projections, energy use will climb by more than 67% by 2050 due to an increase in the global population, the number of

houses and new energy services [18]. These issues increase the energy cost of the building paid by resident users.

In Malaysia, the national energy consumption increased by 210.7% from 1990 to 2009 [19]. Because of a lack of efficiency techniques in the Malaysian building sector, carbon emissions have increased by 235.6%. Policies should be put in place to lower greenhouse gas (GHG) emissions from buildings and boost residential buildings' energy supply efficiency through integrated supply techniques.

### 2.1. Conventional Energy System Designs

A traditional, stationary supply is a non-renewable energy system that generates power and delivers it to a residential area. The electric efficiency from grid generation is about 0.4–0.48 [20]; hence, enormous electricity usage can increase energy loss and cost. As depicted in Figure 1, the separated system in a conventional, stationary supply for residential applications includes the usage of gasoline-fueled vehicles as well as electricity, heat and cooling energy. The classic car uses gasoline as fuel, which has high energy prices and high GHG emissions. The efficiency of the gasoline vehicle is 236.8 MJ/100 km, or 20 km/L [20]. Moreover, vehicles with gasoline fuel contribute to the increase in GHG emissions more than natural gas vehicles. There are 2.344 kg of carbon emissions in one liter of gasoline [21]. Due to the issue of fossil fuel depletion, gasoline utilization must be reduced or it must be substituted by another form of fuel, for example, electricity or hydrogen.

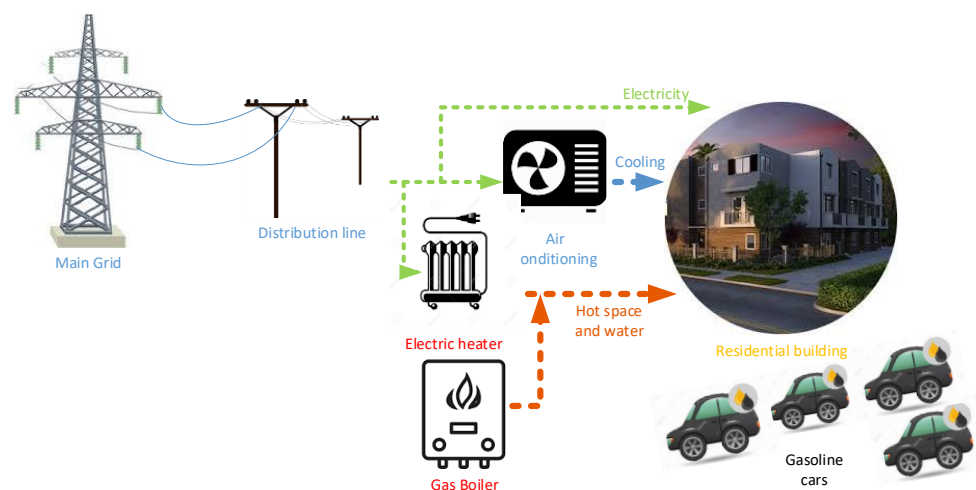

**Figure 1.** Conventional energy system design for residential application.

### 2.2. Integrated Residential Energy System Designs

Integration of one or several energy sources to overcome the low efficiency of grid distribution has been made into a standalone system. For small-scale applications, one house can build 1 kW to 2 kW of standalone power supply, which can be separated or connected to the primary grid. This integration is more efficient, avoiding power losses in the distribution line and optimizing electricity usage, as depicted in Figure 2. A microgrid configuration can be developed in multi-family homes or apartments from one or combined supply sources of non-renewable or renewable energies.

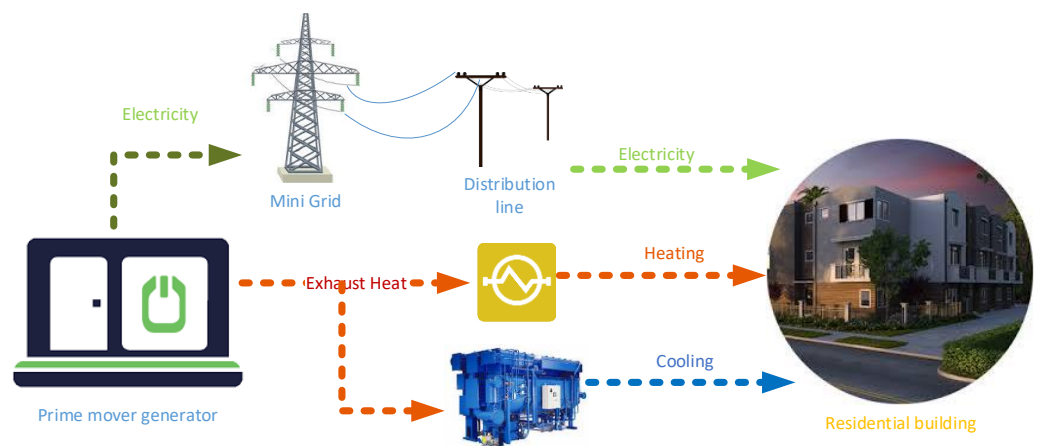
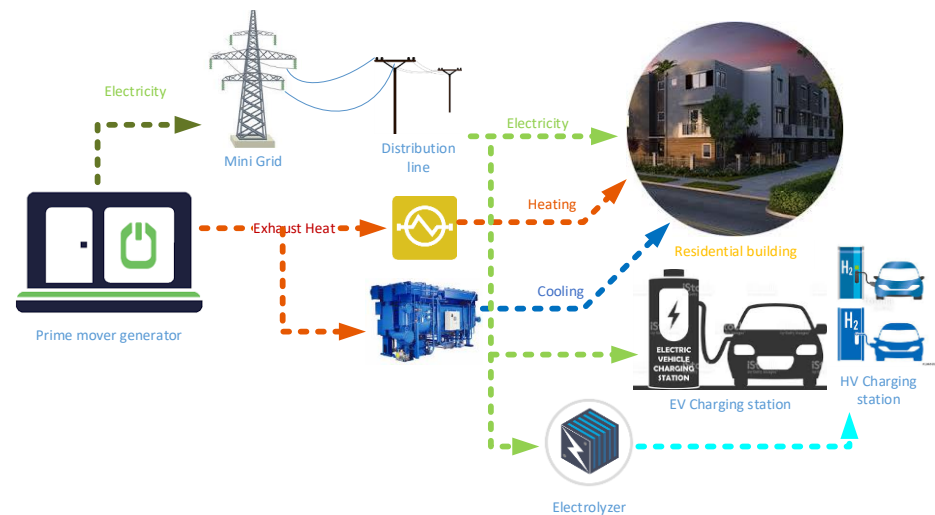

**Figure 2.** Integrated energy supply design for residential application.

The microgrid energy supply's development includes giving residents access to heating and cooling energy and electricity. Various energy sources can simultaneously work as a prime mover to produce heat and electricity. Combined heat and power (CHP) or cogeneration systems employ the prime mover's exhaust heat, which is typically squandered, to generate both electricity and heat for the consumer. The CHP system has been developed into a combined cooling, heating and power (CCHP), or trigeneration, system for further applications, which offers more forms of energy, including electricity, hot water and space and cold water and space. Trigeneration, sometimes known as polygeneration, is a system that may create three or more energy sources from a single or integrated supply system. A polygeneration system can produce fresh water, oxygen, hydrogen and other forms of energy in addition to electricity, heat and cooling.

### 2.3. Advanced Residential Energy System Design

Advanced residential energy systems combine stationary and mobile power supplies, which are attractive for future developments. The idea comes from the trend of vehicle technologies increasing the use of electric and hydrogen as fuels instead of gasoline in modern vehicle types, as depicted in Figure 3. With the development of hybrid or pure electric and hydrogen cars, the opportunity for building a personal recharging/fueling station is not a difficult thing. Personal vehicle chargers can be implemented for single- or multi-family usage, for private use or be shared with the community, while, for a fueling station, an electrolyzer can produce hydrogen from electric sources such as photovoltaic, wind and fuel cells.



**Figure 3.** Advanced energy system design with a vehicle charging/fueling station in a residential area.

Combining stationary and vehicle energy supplies can lower the amount of non-renewable energy used for primary energy needs, improve energy utilization effectiveness and prevent power loss during distribution. Additionally, an integrated system can dramatically lower airborne GHG emissions by using RE as the prime mover. A short payback period and lower energy costs are further economic benefits of an integrated system [22]. Therefore, the design of an energy system that integrates stationary and vehicle energy supply should be well planned based on the users' requirements.

### 3. Energy Generation Systems

Energy systems can be categorized into three types based on their design: single generation, cogeneration and polygeneration/trigeneration systems. Depending on customers' needs, a single power generator generates a single supply consisting of electricity, district heating or cooling. A cogeneration system can produce electricity and hot water or space, electricity and cold water or space or electricity and hydrogen from a single or integrated system. From a single or combined energy source, polygeneration systems can produce more than three energy types simultaneously; while known as trigeneration, the system may have more than three different types of energy, i.e., CCHP and quad-generations.

#### 3.1. Single Power Generation Systems

Single power generators are commonly used to generate electricity through standalone or grid-connected configurations. To enhance the performance of the prime mover, many forms of renewable or non-renewable energy sources can be blended into a hybrid system. A system that combined SOFCs and a gas turbine was implemented in [23], using a system with a size of 500 kW. Power generation systems using fuel cells as the prime mover have been designed and operated efficiently [24]. A study of a hybrid system of SOFCs and PEMFCs was conducted in ref. [25] to increase system efficiency.

The addition of thermoelectric material to the prime mover's exhaust heat is another way to raise efficiency. According to the research, adding a thermoelectric generator to the burner, air preheater or fuel preheater boosts the prime mover's ability to produce electricity [26–29]. Thermoelectric devices can be coupled with most prime mover types to provide additional electricity. Due to their low-temperature operation, thermoelectric materials cannot be associated with all renewable energy sources. Some practical, renewable energy sources that combine well with thermoelectricity include photovoltaic and fuel cells. Fuel cells outperform photovoltaic cells in heat quality and acceptable temperature range for thermoelectric materials [4].

A single power system can produce cooling and/or heat in addition to electric power by using a separate system. For multi-family residential settings, some district heating or cooling systems have been created [30–33]. A single or hybrid prime mover produces the district heating or cooling system and commonly uses a combusting engine to produce more heat. For residential dwellings, a complex analysis was also performed for power sharing design in a district heating and combined heat and power system [34].

#### 3.2. Cogeneration System

Electrical power is not the sole energy required for several power generation applications, especially those in office and residential buildings. Other sources such as air and water heating and cooling systems are also needed continuously. Based on ref. [35], for community residential complexes, unconventional sources are needed, including energy, hydrogen for vehicles, recycled fuel, fresh water and oxygen. To address such needs, the majority of commercial and residential buildings, however, employ separate systems (SP) for power, heating and cooling, which results in inefficient energy use and drives up the cost of energy. An integrated system that can produce electricity, heating, cooling and other supplemental outputs such as fresh water, hydrogen and oxygen is needed to increase system efficiency, energy consumption and energy cost.

The combined heat and power system (CHP) can be regarded as the most straightforward system when building an integrated system. It comprises a prime mover that produces power and heat simultaneously, either as a single prime mover or as a hybrid, and a heating system that recovers the heat energy from the prime mover. When the heat demand exceeds the heat supply, several applications of CHP systems may include an auxiliary boiler. Additionally, it has a heat storage system to keep the extra energy for use when the temperature is low. The CHP is advantageous because it can create heat power as if it were a separate system without additional fuel. This system, which has been developed by a number of businesses, including a collaboration between Ceres Power in the U.K., Hexis in Switzerland and British Gas and Ceramic Fuel Cells Ltd., is anticipated to become the first commercialized, energy-generating system deployed for residential purposes (Australia) [36].

### 3.3. Polygeneration System

Despite the success in developing the cogeneration system, the system cannot fulfil the cooling demand for office and residential buildings. Therefore, when the heat requirement is low, the extra heat from the prime mover is useless, reducing the total system efficiency. Further technology in energy generation has triggered the development of polygeneration, which is equipped with a cooling system and other types of energy, i.e., fresh water, hydrogen and oxygen, to optimize the utilization of heat and fuel and satisfy the requirement of users. In a polygeneration system, heating and cooling demand can be met and electrical power can be generated as the primary output with the same amount of fuel utilization. In several scenarios, cooling devices can be improved using an electric chiller and refrigerator as auxiliary cooling devices when the heat power produced is less than the requirement [37–41].

Polygeneration is also called trigeneration or a combined cooling, heating and electricity (CCHP) system in other applications. A trigeneration or CCHP system serves three types of energy from one or more prime movers in an integrated system. When the system can provide more than three, it can be called quad-generation; thus, commonly, all these systems are named polygeneration systems. Polygeneration systems can produce more energy types than cogeneration and trigeneration systems. For instance, they are more energy efficient and have superior energy waste recovery in addition to providing hydrogen for automobiles and fresh water, energy and heating and cooling for water and space for residential purposes [6,42–44]. Therefore, implementing a polygeneration system integrated with a vehicle station is promising for future residential buildings.

## 4. Overview of Polygeneration Systems

In most applications, a polygeneration system consists of several device types: prime mover, heating, cooling, storage, hydrogen generator and other purifying devices.

### 4.1. Prime Mover

Based on the literature, the development of polygeneration systems has resulted in different types of prime movers being used to serve the system. In [45], combustion-based prime mover technologies included gas turbines, Stirling engines and Rankine cycle units, while electrochemical technologies included fuel cells and electrolyzers. Technologies such as gas turbines and reciprocating engines are commercially viable, while Stirling engines, Rankine cycle units and fuel are still in their early stages. A comparison of the prime mover technologies used in polygeneration systems is shown in Table 1. The comparison includes the efficiency of electrical and system generations and the emissions (CO<sub>2</sub> and NO<sub>x</sub>) from the system generation, including electric and thermal generation.

**Table 1.** Evaluation and comparison of several polygenerational prime movers [45–47].

Prime Movers	Reciprocating Engines	Gas Turbine	Stirling Engines	Steam Turbine	Rankine Engines	Fuel Cells
Advantages	Effective part load performance, very flexible and quick start-up time necessary.	Low maintenance requirements, flexible and compact design and moderate output heat temperature.	Low noise and emission levels, appropriate for household use and possible operation using renewable energy.	Flexibility in fuel, including renewable energy, long life cycle, high system efficiency and flexibility in fuel-to-heat ratio.	Simple design, increased flexibility, low operating temperature and pressure and a wide fuel range are necessary.	High output temperature, low operation emission and noise and high electrical efficiency.
Disadvantages	A substantial number of moving parts, mechanical solid noise and vibration and a high rate of emission.	Inefficient part load performance, unsuitable for start/stop application.	Long start-up time, high investment cost, limited adaptability component.	Bulk construction High initial cost, slow response at partial load, slow start up.	Low efficiency, infrequent research and commercialism in the ORC field.	High capital and investment cost, the design is complex.
Size capacity	Up to 75 MW	Up to 250 MW	Up to 55 kW	50 kW to 100 MW	Up to 250 MW	Up to 2 MW
Electric efficiency	25–45%	18–36%	15–35%	10–37%	15–38%	37–60%
System efficiency	65–80%	65–75%	60–80%	60–80%	80%	55–80%
Life time (h)	20,000–50,000	5000–40,000	10,000–30,000	50,000–100,000	30,000–50,000	10,000–65,000
Fuels used	Diesel, natural gas, propane.	Natural gas, biogas, propane, distillate oil.	Any fuel (natural gas and bio-fuels).	Any fuel (natural gas, bio-fuels and renewable energies).	Any fuel (natural gas and bio-fuels).	Hydrogen, natural gas, propane, methane.
Electrical-to-thermal ratio	0.5–1	0.4–0.7	0.15–0.4	0.9–1.13	0.15–0.4	0.5–2
Waste heat temperature (°C)	80–200	120–350	Up to 85	Up to 85	Up to 100	Up to 1000
Thermal output (kJ/kWh)	3376–5908	3376–7174	-	-	1065–52,753	1900–4431
Part load efficiency	High	Low	Moderate	Low	Moderate	Very high
Start-up time	>10 s	>10 min	-	>5 h	>1 h	>3 h
Noise level	High	Moderate	Moderate	Moderate	Low	Moderate
Investment cost (\$/kWe)	340–1600	450–1500	1300–2000	2000–32,000	1000–2000	2500–3500
NOx emissions (Kg/MWh)	Up to 10	0.1–0.5	0.23	Fuel dependent	Fuel dependent	0.005–0.01
CO <sub>2</sub> emissions (Kg/MWh)	Up to 650	580–720	672	Fuel dependent	Fuel dependent	430–490





**Table 2.** Comparison between different types of fuel cells [47,50–52].

Fuel Cell Type	PEMFC	AFC	DMFC	PAFC	MCFC	SOFC
Operating temp (°C)	30–100	90–100	50–100	160–220	600–700	500–1000
Electrical efficiency (power) (%)	30–40	60	20–25	40–42	43–47	50–60
System efficiency (heat and power) (%)	85–90	85	85	85–90	85	Up to 90
Typical stack size	<1 kW–100 kW	10 kW–100 kW	Up to 1.5 kW	50 kW–1 MW (250 kW typical module)	<1 kW–1 MW (250 kW typical module)	5 kW–3 MW
Electrolyte	Solid polymeric membrane	An aqueous solution of potassium hydroxide soaked in a matrix	Solid organic polymer poly-perfluorosulfonic acid	100% phosphoric acid stabilized in a SiC-based matrix	Li <sub>2</sub> CO <sub>3</sub> /K <sub>2</sub> CO <sub>3</sub> materials that are stabilized in an alumina-based matrix	Solid and stabilized zirconia ceramic matrix with free oxide ions
Fuels	Methanols or hydrocarbons	Pure hydrogen	Methanol	Natural gas	Natural gas, biogas, others	Natural gas or propane, hydrocarbons or methanol
Applications	Transportation, DG, backup power, portable electricity and speciality vehicles.	Military, space, backup power, transportation	Consumer goods, laptops and mobile phones	Distributed generations (DG)	Electric utilities, distributed generations	Electric utilities, distributed generations, and auxiliary powers
Advantages	Advanced start-up time, varies output quickly, compact, no corrosive fluid used	Lower cost components due to a broader range of stable materials, low temperature, quick start-up	A high density of energy storage, no reforming required, easy storage and transport	High cogeneration efficiency	High efficiency, scalable and flexibility of fuel	Internal reformation is made possible by high temperature, which eliminates the need for liquid electrolytes, makes high-temperature, valuable output for various applications and does not require pure H <sub>2</sub> (low-price fuel)
Disadvantages	Expensive platinum catalysts used, high-purity H <sub>2</sub> required	Sensitive to CO <sub>2</sub> in both air and fuel, electrolyte conductivity, aqueous electrolyte management (polymer)	Low power output, methanol is toxic and flammable	High-cost catalysts, long start-up time, sulphur sensitivity	High-temperature corrosion and cell component failure, low power density and a lengthy start-up time	Lengthy start-up times, problems with temperature stress during load after the operation and the need for pricey, heat-resistant materials

In addition to utilizing sunlight as the combined prime mover, a few studies have also concerned geothermal sources using ground source heat pumps (GSHPs). A GSHP works with electrical energy to extract heat from the ground and transfer the heat into the building. It utilizes geothermal energy to meet heating demand instead of burning fuel as boilers do. A study developed a combined GSHP-SOFC prime mover for a trigeneration system in office and residential houses [53]. The analysis considered three types of trigeneration combinations utilizing a boiler, chiller, GSHP and fuel cell based on their capacity. The result revealed that a variety of SOFC-GSHPs achieved significant energy savings.

#### 4.2. Heat Recovery Units

Heat recovery equipment works to recover the thermal energy from prime mover exhaust gas streams to meet heating demands [46]. The units can increase system efficiency without any increase in fuel utilization. Heat exchangers are the most accurate heat recovery equipment and can be made of a simple tube and shell, plate, fin or even micro-channel design. They are marginally different to a HRSG, which can generate heat and steam water from the rejected exhaust gas. The components are frequently used in heat recovery mufflers, which are utilized with reciprocating engines to recover exhaust heat. They produce less noise and pressurized steam and hot water than HRSG devices in the 370 °C to 540 °C range [54]. However, the kind of exhaust gas has an impact on the muffler's stack exit temperature and the quantity of heat that can be recovered [55]. Since the high-back-pressure issue can decrease muffler capacity, regular maintenance and cleaning are required to maintain the engine's performance.

Thermoelectric generators (TEGs) are yet another choice of heat recovery device. An appealing method for converting heat to electricity is by TEG. By converting exhaust heat into electric power, a TEG serves to raise the primary mover's efficiency. The electrons from n to p semiconductors travel through the TEG material when there is a temperature gradient, creating the voltage needed to drive the external load [56]. The TEG performance is different based on the semiconductor type, p or n, and the operating temperature range.

TEGs have been widely applied for recovering heat in both stationary and mobile machinery. Heat recovery for a high-temperature prime mover is optimally used for fuel-cell-based power generation systems. The system efficiency of a heat recovery system can be increased by up to 5% from the base case by using a TEG in several components, such as in the burner, exhaust heat and the air and fuel preheater [57]. As a result, using a TEG to produce power backup for the prime mover in both single and multigeneration systems has been commercialized.

#### 4.3. Cooling Units

Polygeneration systems generate cooling from the rejected heat exhaust of the prime mover, eliminating the need for additional fuel to meet cooling and air conditioning demands. Hot water, steam and exhaust gas range in temperature and can all be wasted heat sources [46]. In order to continually satisfy the need for power, heating and cooling, the optimum design of a polygeneration system must consider the best combination of prime mover and heating and cooling unit based on their specifications.

Instead of the mechanical compression used by refrigerators, sorption cooling methods (such as absorption and adsorption) use thermal compression to produce cooling. While an adsorption cooler creates cold air or water through a material that adsorbs the refrigerant vapors, an absorption cooler operates with a pair of working fluids: refrigerant and absorber [58]—the basic absorption cooling cycle includes four parts: generator, absorber, evaporator and condenser. Lithium bromide–water (LiBr/H<sub>2</sub>O) and water–ammonia (H<sub>2</sub>O/NH<sub>3</sub>) are commonly the functional absorbent/refrigerant pairings for absorption cooling.

#### 4.4. Hydrogen Generation Units

Some diversifications have been created to manufacture a new fuel to decrease the consumption of non-renewable primary energy sources, fossil fuels and coals. Hydrogen combustion is cleaner and better for the environment than oil and natural gas combustion. However, hydrogen costs more than natural gas and oil because it is a relatively new technology. As a result, there has been an attractive increase in the development of hydrogen production, particularly for household fueling applications [59].

The development of diverse hydrogen production systems employing non-renewable and renewable energy began when hydrogen was established as the future fuel. Steam methane reforming, coal gasification, biomass burning, nuclear power and water hydrolysis are a few methods for creating hydrogen [60]. The method for producing hydrogen through water electrolysis is significantly more environmentally benign than other methods. The technique for creating ultra-pure hydrogen through hydrolysis was discovered 2000 years ago [61]. However, only small-scale applications are covered by the production. Of the hydrogen produced worldwide, 4% is produced via electrolysis of water. Hydrogen production on a big scale is used in home fueling stations and the marine, rocket, spacecraft, electrical and food industries [62]. Polygeneration can be explicitly applied to produce fuels such as hydrogen and oxygen through an integrated system, as depicted in Figure 5. In the research, a system was designed to supply 500 MW of electricity, hot water and hot air, while the excess electricity was used for hydrogen production [63].

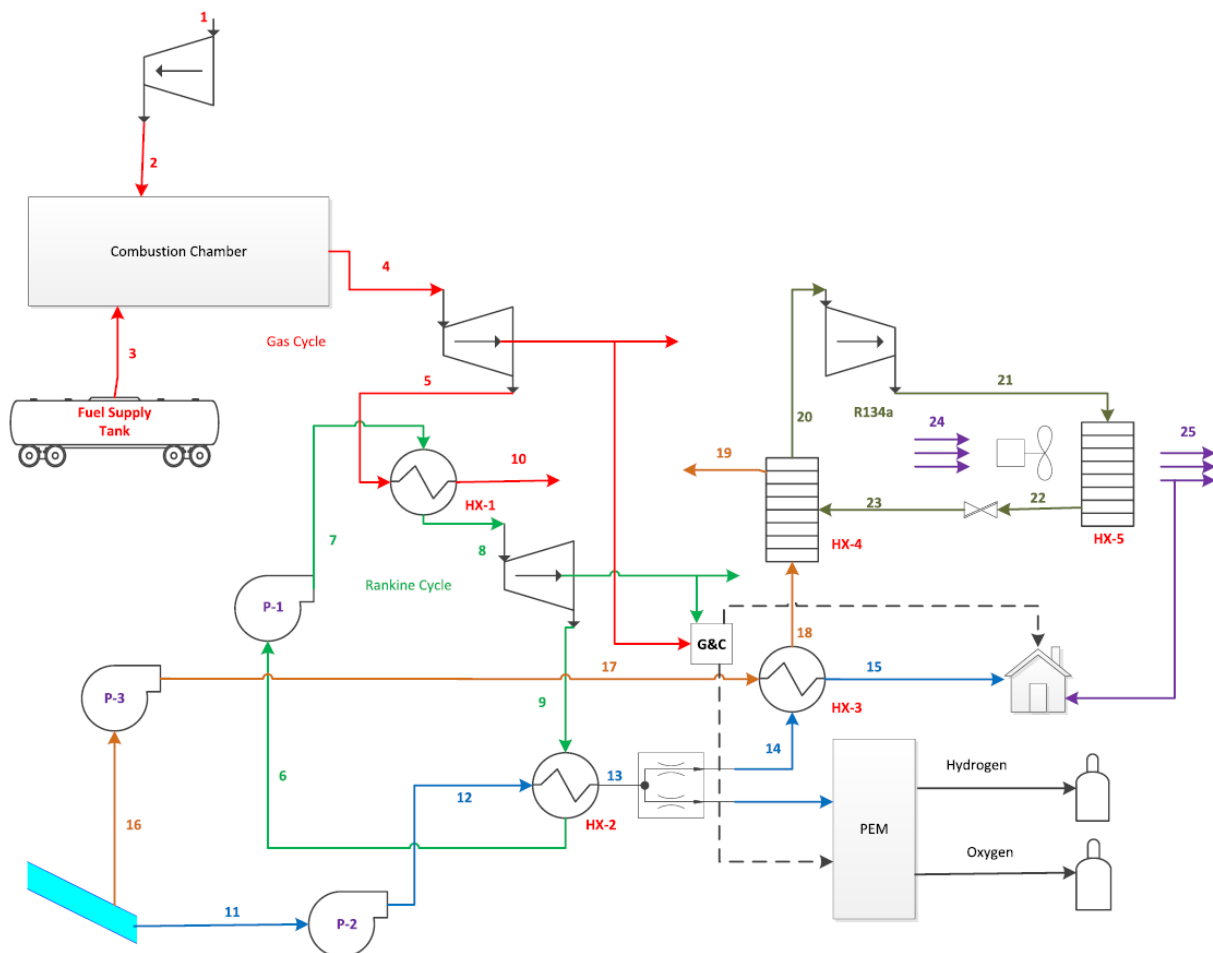

Figure 5. Polygeneration system for hydrogen generation unit for residential scale [63].

#### 4.5. Storage Units

In the production of heat and power, erratic and disjointed power, heating and cooling reduce system efficiency, raising energy costs. Storage units are required to store excess energy during times of low demand and use the excess during periods of high demand. Utilizing storage facilities improves operational hours, fuel efficiency and system effectiveness while decreasing capacity. When applying electric tariffs, using storage can also lower energy costs when peak load hours are considered.

Utilizing electrical energy storage becomes more crucial in order to reduce the import of grid electricity. Additionally, it extends the system's operational hours during high grid demand and when energy prices are high. Based on the chemical components of BES, certain contemporary technologies have been adopted: lead–acid (LA), nickel (Ni), sodium (Na), lithium-ion (Li) and metal–air batteries. LA batteries are the oldest technology, are rechargeable, have low cost and simplicity when being manufactured and have a quick chemical reaction and good life cycle [64]. Despite the advantages that make this technology the largest in the market, LA batteries also have some drawbacks: heavy metal components which generate toxic and hazardous material and a lot of water production from the discharging process [65].

In addition to electrical demand, the fluctuating characteristics of heat and cooling demand also significantly affect system efficiency. The occupant's behaviors, particularly for residential applications, can occasionally necessitate more electrical energy than is required for heating and cooling. Due to the increased electrical demand, the primary mover's exhaust heat is temporarily rendered useless. In order to improve the system efficiency, thermal storage is essential as electrical storage.

The most popular type of heat storage utilized for combined heat and power generation is sensible heat storage (SHS). It functions by supplying the substance with energy and raising the temperature without altering the material's phase [66]. The temperature of the substance used to transfer heat energy (often solid or liquid materials), the fluctuating inside temperature of the storage and the quantity of material stored all have an impact on SHS capacity. Water, sands, oil and rock beds are used to transport heat for any application. Water has more benefits than other materials since it is inexpensive and readily available, but it also uses solid resources such as metals, rocks, concrete and bricks. To reduce upfront and ongoing expenditures, the appropriate materials for sensible heat storage are chosen [67]. The multi-objective optimization of this study also took into account accessibility and environmental consequences such as carbon footprint.

Hydrogen is typically created using an electrolyzer and stored in a hydrogen tank for some purposes, mainly when using fuel cells as the primary mover. Hydrogen-based energy storage (HES), which is ecologically friendly, has various benefits for both fixed and mobile applications. Additionally, it provides a level of electrical generation continuity that is not possible with intermittent, renewable energy sources such as photovoltaic and wind generators. This storage type, however, lacks design and evaluation studies due to its infrequent application. According to research by the Ministry of Energy, Green Technology and Water [67], hydrogen-based storage is frequently paired with a hybrid renewable energy system (HRES), which mainly look at design factors, including security, operability, final use, energy and efficiency performance.

### 5. Applications of SOFC-Based Energy Generation Systems in Residential Applications

In the most recent advancements in renewable energy, fuel cells (FCs) are recognized as the new and most promising kind of source for the future [68]. PEMFCs, DMFCs and PAFCs are designated for low-temperature operations in the fuel cell application, whereas MCFCs and SOFCs are designated for high-temperature activities. Low-temperature fuel cells can be used in mobile applications such as vehicle transportation and in military and governmental buildings [69–71]. On the other hand, high-temperature fuel cells are more suitable for stationary applications such as power generation systems due to their higher-temperature functioning and higher efficiency [72,73].

Because of its benefits relating to the flexibility of the electrolyte material and adaptability in using hydrocarbon fuel, the SOFC is the fuel cell type designed for stationary power production [74]. The SOFC can potentially be applied for hybrid power generation to boost electrical output and for combined heat and power generation to deliver more than electricity due to its high efficiency and proportionate heat-to-power ratio.

The number of papers describing the SOFC as a power producer has been rising yearly, as can be seen in Figure 6. SOFC application is split into single power generation, cogeneration and trigeneration/polygeneration systems based on the type of power generated. Early in 1992, research into SOFCs as a prime mover for single power generation began. The majority of research from 1992 to 1993 focused on optimizing the stack SOFC to produce more electricity and boost power efficiency. In 1994 and beyond, research on the hybrid system consisting of SOFCs and gas turbine grew since the hybrid configuration significantly affected system efficiency. Since 1995, there has been a significant increase in studies on using SOFCs' exhaust heat. The figure shows that the cogeneration system's application increased from 2014 to 2015. The number of papers on cogeneration SOFCs in residential settings declined from 2016 to 2017. The trend for cogeneration SOFCs increased from 2018 to 2021 due to larger applications that implement the fuel cell. The increase in attention paid to cogeneration systems cannot be separated from the fact that the output is not limited to heat and power but also includes heat and cooling, power and cooling, syngas and hydrogen or clean water as a side production.

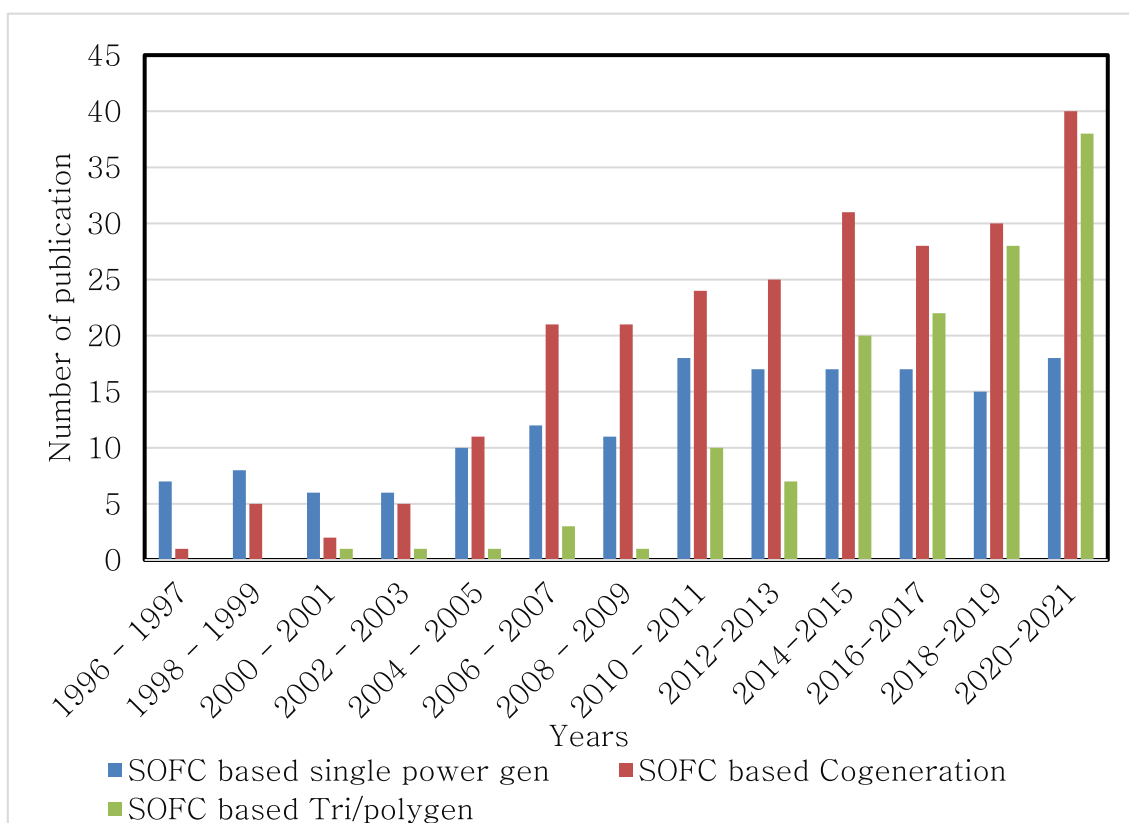

**Figure 6.** The trend of publication numbers for SOFC power generation in residential applications.

On the other hand, even though it is not as substantial as the research into the cogeneration system, research into trigeneration or polygeneration SOFCs is growing. This research began in early 2000 and was designated as a novel topic. Therefore, the trend of research into trigeneration/polygeneration systems was still attractive for the next five to ten years. It was analyzed by a number of publications on SOFC trigeneration/polygeneration systems for residential applications. The increase in interest in utilizing SOFCs in polygen-

eration systems was triggered by the prediction of the price reduction of SOFCs for the next five to ten years [75–77].

Moreover, the increase in polygeneration for residential applications cannot be separated from the environmental issue. Based on the energy plan of the government, Malaysia has a target to reduce carbon emissions by up to 45% by 2030 [78]. Therefore, applying SOFC-based polygeneration systems is attractive for saving primary energy and reducing carbon emissions in Malaysia.

The use of SOFCs as a primary mover is divided into two configurations based on the architecture of household energy planning, namely integrated stationary and vehicle supply. Integrated supply covers the application of single power generation, cogeneration and a trigeneration/polygeneration system. Meanwhile, integrated energy supply and vehicles combine stationary and mobile applications, for example, single-family or multi-family homes with electric vehicle charging stations. Another application affixes a small-scale fueling system to a residential structure. A recent study focused on the design of a power-to-hydrogen station to provide fuel for vehicles using polygeneration systems. The combinations of energy supply to generate hydrogen were assessed based on real-time demand profiles [79]. It was found that the modular, hybrid energy station that was proposed had a significant impact on future refueling station design and residential housing in the neighboring area.

In its application related to fueling stations, consideration must be given to designing a transport system for hydrogen production. An integrated hydrogen production and transportation system was designed to support the government in developing the early stage of a fuel cell electric vehicle (FCEV) [80]. The research intended to develop a transportable 700 bar hydrogen fueling station with an off-the-shelf component cost of less than 23% of the capital cost of the current stations in the U.S., as depicted in Figure 7.

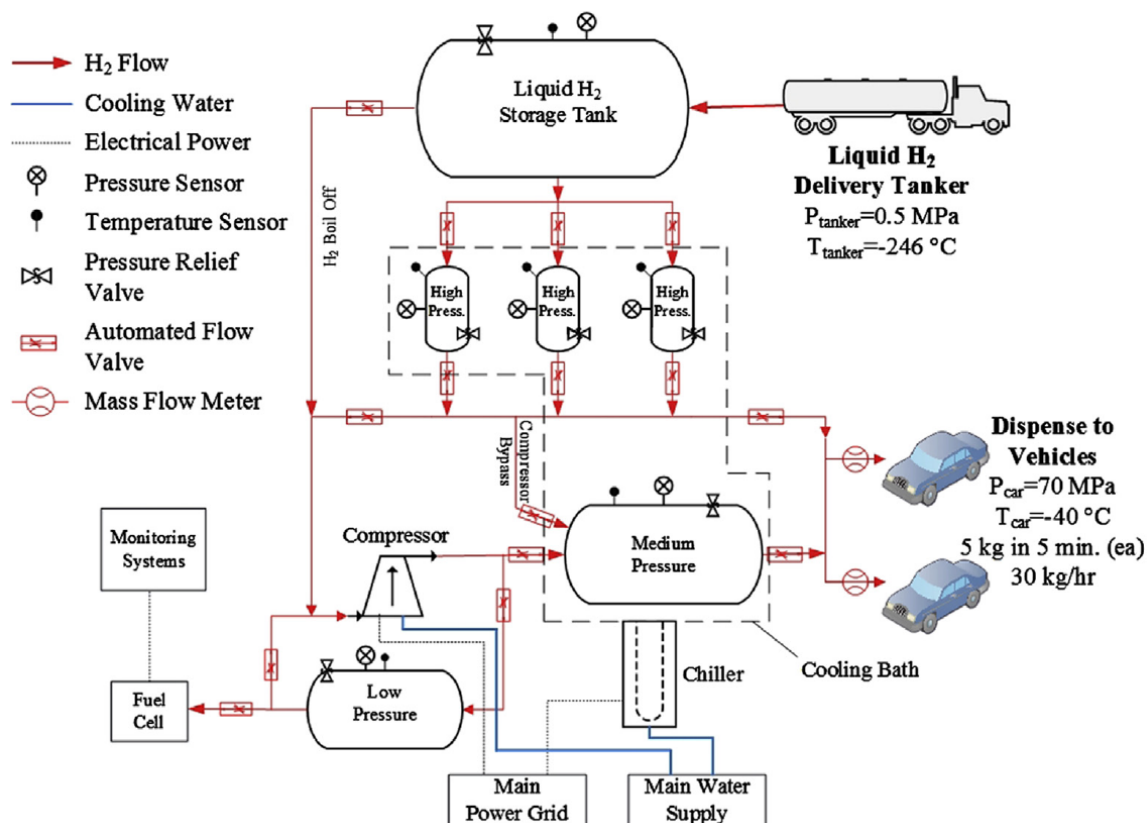

Figure 7. The design of a transportable vehicle fueling station [80].

## 6. Energy Planning for Designing a Polygeneration System

Due to the high investment cost of SOFC-based energy generation systems, energy planning should be conducted to design a highly efficient polygeneration system. The literature on energy planning for residential applications lists three strategies: configuration review, operating strategy design and capacity and operating point optimization. The detail of the strategy is presented in Sections 6.1–6.3.

### 6.1. Evaluation of Configuration Design

Structure evaluation, topology assessment or system synthesizing is essential for designing a polygeneration system. Starting with the choice of the prime mover and its topology, polygeneration structure optimization is undertaken. A SOFC can be employed as the prime mover in a standalone or hybrid form in SOFC-based polygeneration. In a freestanding arrangement, the SOFC's electrical output and waste heat are used; in a hybrid configuration, the SOFC can be coupled with a turbine-driven system to produce more electricity. The organic Rankine cycle (ORC), biomass and solar system have all been used to study a combined prime mover integrating SOFCs and renewable energy.

Further, selecting one or more prime movers allows for the examination of polygeneration [81]. Studies have shown polygeneration structure optimization based on the chosen primary mover from a gas engine, PEMFC or SOFC. Another study focused on LNG-based SOFC polygeneration system assessment in desalination water application [82]. The research assessed two combinations of SOFCs with heat recovery systems to analyze the system performance through system efficiency. A polygeneration system employing SOFCs as a prime mover was investigated for water desalination and hydrogen production [83]. Based on the evaluation, the system produced electricity of 4.4 MW, a refrigeration capacity of 0.16 MW and 0.96 kg/s of desalinated water.

Structure evaluation is not concerned with choosing the right prime mover but with designing a suitable heating, cooling and storage system and its connection to the grid. Guidance for selecting the configuration of a polygeneration system based on energy and economic and environment factors was presented in the review in [46]. The heat-to-power ratio and its initial cost can be used to select the appropriate heating and cooling units, particularly for SOFC-integrated cooling, heating and power systems. Burners and heat exchangers are the most widely utilized components for recovering SOFC exhaust heat. Some research used an HRSG unit to provide space heating from the exhaust gas of SOFCs. A double- or triple-effect absorption chiller is the best cooling system for maximizing system efficiency due to the high exhaust temperature from SOFCs. However, additional heating in the form of an auxiliary boiler and additional cooling in the form of an electric chiller can be employed for periods of peak heating and cooling demand.

Since the environmental aspect has become an urgent parameter when creating a sustainable system, several emerging polygeneration systems have been considered, reducing carbon emissions through some technologies such as carbon capture and carbon converters. A study investigated a polygeneration system that captures and converts carbon into methanol/power [84]. The carbon footprint assessment showed the remarkable ability of the proposed system to reduce carbon emissions.

Due to their linear power-to-capacity ratio, batteries and sensible heat storage are frequently utilized for electrical and thermal storage. While sensible heat storage capacity is determined by the storage temperature and pressure, batteries measure capacity, charge rate and discharge. Both electrical and heat storage significantly affect the continuity of CCHP operation and reduce the appropriateness of the grid-connected system. However, capacity and structure evaluations of these storage units should be conducted to optimize their cost and efficiency.

### 6.2. Operational Strategy Design

Operating strategy optimization has been carried out through various management techniques to decrease energy consumption and enhance energy savings. In contrast

to electricity generation, polygeneration management takes into account electric, cooling, heating and other energy generation requirements. Optimizing energy flow while balancing each component to meet all demands is the operational strategy's most important goal. The operating procedures now in use for polygeneration systems are classified into three categories based on their approaches: conventional, novel and intelligent.

According to the required load, conventional operating techniques manage the energy supply from the prime mover and cooling and heating units. Electrical and thermal loads are used to control the energy source in CCHP or polygeneration systems. Conventional operating strategies consider three techniques: following thermal load (FTL), following electrical load (FEL) and combined FEL and FTL strategies.

The FEL uses an operational method known as electric demand management (EDM) to control energy sources in order to satisfy electrical load without taking the thermal load into account. The prime mover for the application is created and run optimally based on the electrical load profile. The thermal requirement in FEL is now the second criterion that must be met by prime mover generation. The auxiliary boiler creates an additional heat source if the primary heating and cooling systems cannot keep up with demand. The following electrical load is superior as it increases energy savings for some countries with hot, humid climates or tropical environments since it reduces the need for heating and cooling equipment [85]. The polygeneration system, which is connected to an electrical heater and air conditioning and refrigeration units, known as the heating, ventilation and air conditioning system (HVAC), also uses the FEL method.

On the other hand, while developing and running a polygeneration system, FTL or thermal demand management (TDM) uses an operation to meet thermal demand. The primary mover's capacity is intended to meet thermal demand; however, if electrical need cannot be met, further grid imports of electricity are necessary. The FTL approach is typically used in four-season countries and regions with significant thermal demand. To meet cooling demand in summer, the prime mover produces more heat energy, whereas the exhaust heat is needed for space heating and the household hot water system throughout the winter season. A heat storage unit should be utilized to boost the polygeneration system's continuity and reduce energy consumption during the peak load period.

Utilizing conventional strategies to operate polygeneration systems results in concerns relating to running costs, system efficiency and energy conservation. Energy waste occurs when an electrical or thermal source produces more energy than can be used. As a result, some research explored combining the FEL and FTL strategies in an approach used for the system [86]. In other studies [87,88], in order to cut down on energy usage, operating expenses and carbon dioxide emissions, a combined FEL/FTL working approach was investigated. In ref. [89], to maximize the excess from both the FEL and FTL, researchers developed a novel operation called minimum distance (MD) and matching performance (MP) assessment.

Numerous unique techniques, including the seasonal operation strategy, time-based, emission-based strategy and economic-based and energy-storage-based strategy, were brought about by the more intense development of optimization strategies for polygeneration systems. The seasonal operation approach operates the heating and cooling systems to meet both demands while taking into account climate change throughout the year. During winter, a heating unit is utilized heavily while a cooling unit is utilized to the fullest. The design should take into account a few possibilities for using auxiliary heating or cooling units during the period of peak load. In order to protect the primary heating and cooling system from the exhaust heat of the prime mover, an auxiliary boiler and electric chiller are used as an alternative. In ref. [90], a trigeneration system was optimized by the proposal of two season-based strategies: summer operation and winter operation. The research took into account energy tariff parameters to decrease energy costs and increase energy saving. Another study proposed a variable electric-to-cooling ratio following climate profiles to enhance the operating strategy of a polygeneration system [91]. Considering three climate temperatures, i.e., hot, cool and moderate, the study defined a variable electric cooling ratio



compared to a constant electric cooling ratio (ECR). In ref. [92], three operation strategies were investigated for optimizing the design of a SOFC-based trigeneration system, i.e., based load operation, thermal match operation and electrical match operation.

Energy storage is considered to enhance energy operation and increase energy saving. Some studies considered employing heat energy storage to increase heat energy saving [93], while others preferred to use a series of batteries as electrical energy storage to improve electrical energy saving.

A time-based operation, or schedule, is applied during a specific time and period to fill the load. For a polygeneration system, the prime mover and heating and cooling units are operated during a particular time and turned off if the period is already finished. This strategy was applied in ref. [94] to improve energy saving and heat coverage in a polygeneration system. The scheduling operation strategy was also used in [95] to increase economic profit from a combined heat and power system. The study proposed four schedules for selling excess energy from the system: selling electricity to the neighbor, selling cooling energy for the neighbor, selling heat energy to the neighbor and selling electric power to the grid. A time-based operational strategy was also proposed in [96] to design a SOFC-based CHP generation system. The study investigated three schedules: winter summer day, peak day and combined summer–winter day for two days.

In economic-based strategies, energy tariffs are primarily applied to minimize energy costs. Interestingly, application of energy tariffs has been proposed for four different load management types: following electrical load, base load, continuous operation and peak saving load [93]. A study considered two types of tariffs for buying or selling via the grid connection. Cost optimization was also implemented to reduce the system's cost and emission of carbon dioxide [97,98]. It compared cost optimization with FEL and FTL as the existing operation strategies.

Management of energy dispatch is essential for improving the effectiveness of the energy flow between the prime mover and the heating and cooling units. The objectives are to satisfy all the load demands and enhance the system's profit.

An adaptive neural network (ANN) for energy management was implemented to design the model of an energy source system and predict the future load requirement. In ref. [99], an optimum design based on an expected model using the Lavenberg–Marquardt ANN method was developed. The research performed the technique to design a CCHP system and to analyze the energy destruction and efficiency of the optimum model. In ref. [100], a CCHP design was optimized using a back propagation technique taking into account energy and exergy analyses. The research claimed that the result of the predicted model had a precision of approximately 0.1% compared to the actual model.

Fuzzy logic (FL) is a simple approach that can be implemented for several types of power and heat generation studies. The input and output are determined in the fuzzy range from 0 to 1, and several rules are applied between the input and output. FL works with multiple inputs and single/multiple outputs. For controlling energy output, the temperature from a storage tank and the temperature from the room are employed as the input for fuzzy logic control [101]. Another study used fuzzy selection to optimize the size and operating strategy of a power generation unit (PGU) in a polygeneration system. [102]. It considered seven models of a prime mover with their operating strategy and three sub-models, i.e., energy, economic and environment. The fuzzy selection technique was applied to analyze the optimum design based on energy, economic and environmental considerations. Another study conducted optimal, FL-based energy management [103], considering thermal and electrical loads and storage temperature as the inputs to generate electricity from the prime mover to reduce energy costs and CO<sub>2</sub> emissions. A recent study proposed two-stage fuzzy management of electricity, cooling, heating and hydrogen supplies in a polygeneration system [2].

### 6.3. Optimal Design of Polygeneration Systems

The design of a polygeneration system must be adequately developed for various reasons, including fluctuating load pattern, climatic circumstances, governmental restrictions and other factors. An inefficient design approach can result in a system's emissions rate increasing, significant, high investment costs and a decline in system efficiency. Moreover, an overdesigned polygeneration system leads to energy waste, while a less designed system leads to an intermittent supply and decreases its reliability. Two types of factors influence the design of polygeneration capacity, namely internal and external factors. Regarding internal factors, some parameters cause the design difference: the components' specification and capacity. The prime mover capacity is the most crucial consideration when developing a polygeneration system. Increasing system efficiency also depends on the effectiveness of the heating and cooling equipment. The lifetime of the prime mover, system continuity and increased system dependability during peak hours can all be improved by adding or not attaching the storage units.

External design considerations for polygeneration systems include application type, load behavior, climate, regional conditions and governmental laws. Polygeneration is divided into four varieties based on its capacity: large-size, medium-size, small-size and micro-size capacities. Large- and medium-sized structures are frequently employed in industrial applications, whilst medium-sized and small-sized structures are commonly utilized in office and academic buildings. However, for residential applications, a micro-sized polygeneration system that can work with microgrid power generation is preferred.

The heating and cooling unit requirements differ in different climates and regional conditions. In four-season countries, heating units are more dominant during winter and fall than cooling units are during the summer and spring seasons. In contrast, hot and tropical countries need more cooling units than heating for space and water. Some regulations mean that exporting excess electricity to the grid is not allowed in some countries, i.e., China and Japan [104,105], while others in the U.K. and U.S. allow exporting electricity to the grid through feed-in tariffs regulation. For ASEAN countries, feed-in tariffs for renewable energy sources, i.e., solar and geothermal sources, have been regulated, as in Vietnam, Thailand, Singapore, Indonesia and Malaysia. However, the regulation for exporting electricity back to the grid has not been established yet for other renewable energy types such as fuel cells. The government regulation allowing or not allowing the export of the excess influences the operating strategy and design of polygeneration (grid-connected or standalone application), affecting operating cost and profit from feed-in surplus energy. For several applications of CCHP independent from the grid, battery utilization as energy storage is preferred to save excess energy and increase system efficiency [106–110].

In several studies, optimizing the design included the system size and operating strategy at two optimization stages. The complexity of the optimization procedures can be tackled by implementing robust techniques and simply modeling the components. A study implemented the two-stage optimization to design a polygeneration system in desalination water application [111].

#### (a) Size Optimization

After reaching the optimum topology of the system, it needs to size the component capacity to avoid oversized or lack of source during operation. For a polygeneration system, the optimization of size capacity should be conducted with various power generators, including electricity, heat and cooling generators. Although the prime mover is the main component that influences heat and power generation, heating and cooling units' capacity must be determined correctly in line with the load requirement. For the system attached to storage units, such as storage units for heat, electrical energy or both, accurate sizing influences the initial cost reduction and increases the system's continuity to satisfy the load demand. Adequate sizing is also required for auxiliary devices, i.e., power electronic units (PCU) such as inverters and converters, BOP units such as reformers, the preheater and combustor and the boiler and electric chiller for additional heating and cooling units.

In applications combining SOFC-based polygeneration with renewable energy such as geothermal, wind and photovoltaic energy, component sizing is required to design a continuous energy generator that can meet the electric load.

Optimization in sizing the polygeneration system has been attractive in recent years. This increase aligns with the future objective to design an efficient and compact trigeneration system for research and commercialism. A study optimized a system for the Mediterranean, considering the size of the prime mover and absorption chiller using partial loads [112]. Moreover, a study performed size optimization of SOFC capacity and SOFC shares in a CCHP system [113]. Some parameters, such as electric-to-heating and electric parameters, were considered to determine the optimum combination of SOFCs and other prime movers, such as steam turbines and gas turbines, with HRSG as a heat recovery unit. In addition to conducting topology evaluation, the study also optimized the cogeneration capacities, including that of cogenerated thermal and electrical power [114]. The capacity of the auxiliary boiler and the capacity of sold/bought electricity to/from the grid were also considered. In his thesis, Elmer [115] designed a multigeneration system consisting of SOFCs, a dehumidifier and cooling units to provide a heat and power supply for a residential area. Sizing of the SOFC capacity, dehumidifier and cooling capacity was conducted to increase efficiency and decrease system cost, primary energy demand and carbon emission. In addition to performing topology evaluation, the authors in [81] also performed sizing of the prime mover, hydrogen tank and battery.

For polygeneration generation, the storage is crucial, affecting system efficiency and energy savings. Some studies were concerned with optimizing and conducting parameter analysis of storage utilization. In ref. [116], the research proposed a novel technique to design optimum heat storage. The study considered the volume and operation period to estimate the contribution of heat storage and increase primary energy saving, the coverage ratio of the heat load and the estimated economic benefits. In ref. [98], the authors optimized SOFC capacity and heat storage to optimally meet a single family's residential power and heat requirements. They analyzed the effect of utilizing batteries for heat and power generation energy saving, considering four strategies and combinations of prime movers and heating units. Another study designed hot water storage and its operating temperature to optimize heat and power generation [117]. The study revealed that the operating temperature of heat storage affects the primary energy saving of the system. In ref. [118], research estimated a model of optimized heat storage capacity based on the input temperature from the power and heat generation system to optimize heat accumulation throughout night hours (8 h).

However, most previous studies used a grid connection as power backup for when the polygeneration system cannot fulfil the electric load demand [93,105,119–123]. Prime mover sizing is conducted to satisfy load base requirements, while electric energy is imported from the grid during peak load duration. The tariffs for importing and exporting electricity fluctuate based on the load requirement. Especially for residential applications, the peak hours rate usually occurs at night and is higher than the daily consumption. In some countries, regulation for grid-connected and feed-in tariffs is far from government regulation. Some studies analyzed battery utilization as a replacement for a grid connection [106,108,124–126]. However, further investigation is required to model the design, analyze and manage an integrated polygeneration system that is fully independent of grid connection.

#### (b) Operating parameters optimization

In addition to the proper topology design of the polygeneration system, optimum operating conditions can affect the system efficiency and reduce the operation cost. Especially for SOFC-based polygeneration systems, running the prime mover in the part load operation benefits energy efficiency and economic aspects [127,128]. Part load operation in SOFCs can be conducted by controlling current density, fuel utilization, flow rate and temperature. Performance analysis is performed based on these parameters by implementing two operating point cases to minimize renewable energy consumption and carbon dioxide

equivalent [129,130]. The result of multiple studies revealed that a system with lower fuel utilization also has lower electrical output power and efficiency yet higher system efficiency. In ref. [131], the researchers conducted a performance analysis of a SOFC-based polygeneration system considering cathode and anode flow input and temperature.

An optimum operating condition is not only applied for the prime mover but also heating, cooling and storage units. Optimizing working conditions for heating units include defining the optimum temperature for the heat exchanger, heater unit and domestic heat water output. Furthermore, the optimum power ratio for heating also affects the heating unit's performance. For cooling unit optimization, defining the cooling temperature for chiller or refrigerator units and the power-to-cooling ratio are also beneficial for increasing cooling performance. Cooling performance is defined as the cooling power at the evaporator divided by the cooling at the generator. The cooling ratio for a single-effect absorption chiller is about 0.7, while, for a double- and triple-effect absorption chiller, it can reach up to 1.2 and 1.5, respectively [132]. For storage unit operation, an optimum operating condition value can be defined from the working temperature and pressure of the heat storage. For electric storage, operating conditions are characterized by working voltage and charge/discharge rate. Working parameters for hydrogen storage can be defined from its operating pressure and the charge/discharge rate of hydrogen.

## 7. Guidelines for Optimizing the Design of Polygeneration Systems

Designing a polygeneration system is the first step before executing and developing an entire system. General guidance for planning a polygeneration system is presented in Figure 8. Defining the prime mover is the primary step in determining whether the polygeneration system will use a single energy conversion device or integrated devices. The type of prime mover is also essential for designing it for single use or in a hybrid configuration. If the prime mover is expected to have emissions that can be used, it is better to combine it with another conversion device that makes it worthwhile to generate additional power.

The second step in designing an optimal polygeneration system is determining the type of primary source. The primary source, called fuels, is mainly related to the kind of prime mover chosen. However, since several prime movers have become more flexible in using renewable or non-renewable sources, the decision is from the perspective of cost or the environment. Renewable energy is the best choice to make a system with a low carbon footprint, yet a mixture of renewable and non-renewable sources sometimes happens when considering fuel costs [133–135].

In polygeneration system design, auxiliary energy production must be determined depending on its application. When using polygeneration for residential areas, basic needs such as heating water and space, cold water and space, fresh air and water are essential. Thanks to the development of construction and urban layout technology, it is possible to integrate residential areas and refueling stations in the community [1,21,136–138]. For an integrated residential area with a vehicle fueling station, extra electricity and/or hydrogen is an excellent choice to be considered. After deciding on the polygeneration components, a criterion must be determined for assessment. It can be one or more to assess the possibility of the design through some synthesis analyses [139]. When the first assessment has been performed, the third stage can continue to define input parameters for the optimization process. When using renewable energy sources, some parameters usually used for residential applications are electricity usage, hot or cold water, hot or cold space and climate profiles such as sunlight, wind speed or rain precipitation. The tenants' driving distance and behavior must be considered when integrating the residential area with a vehicle fueling station to know the system's load profile. The second assessment can be performed by running the simulated system with the load profiles based on its application.

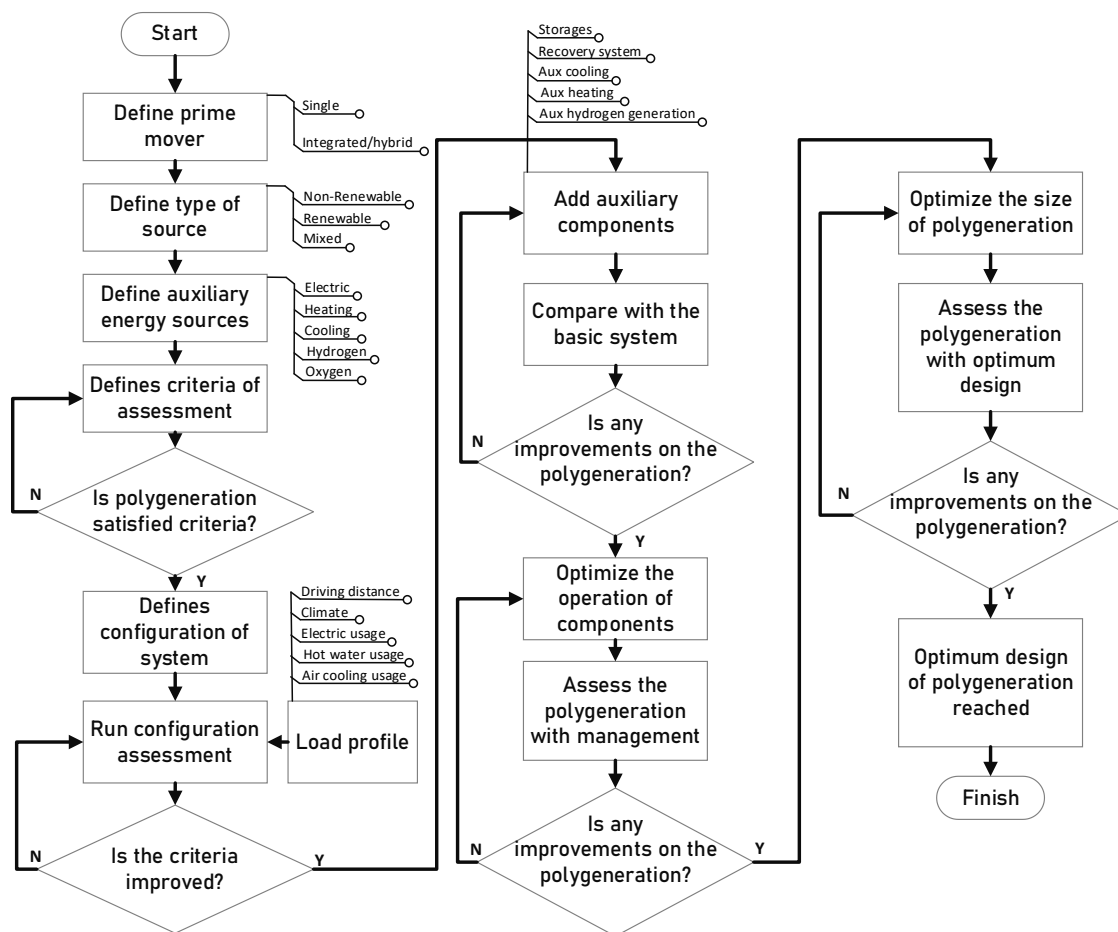

**Figure 8.** A flow chart of guidelines for optimizing a polygeneration system.

When running the second assessment, the same criteria must be used to analyze whether the configuration can cope with the load profiles. If imbalanced situations exist between the supply and demand in the system, some auxiliary storage could be an option. If there is a huge gap that is a waste of the supply, storage can be added for electricity, heating, cooling or even for hydrogen if the prime mover needs hydrogen as a fuel or the vehicles are based on fuel cell engines. A comparison between a separated basic system and the proposed polygeneration system should be carried out to analyze the improvement in terms of prior criteria.

An additional operating system can be added to improve the operation of the polygeneration system. Conventionally, the process of a separated system follows one criterion to satisfy either based on electricity or heat profile. However, since more energy types are produced, polygeneration needs more complicated operating procedures. More measures can be considered to set a non-dominated solution for the system. Some advanced management approaches have been proposed to overcome the complexity of polygeneration, such as artificial intelligence (AI) and metaheuristic methods [2,43,44].

After assessing the polygeneration system for better operational management, the last stage is to optimize the capacity of the polygeneration system. Even though additional storage and/or auxiliary devices have been attached, the management improvement affects the system's energy flow. The size can be optimized after all the components and management are set up. Since many elements, parameters and criteria must be considered, the optimization process can be challenging. The conventional numeric method might not be suitable for the polygeneration case, yet, thanks to the development of metaheuristic methods and AI, complex problems such as polygeneration can be solved by those methods without hassle.

By using this guideline for designing a polygeneration system, researchers can save more time and find an optimum solution for their design before executing it as a prototype or an entire system. Even though the parameters mentioned in this guideline are specified for residential applications, other applications can use a similar procedure. The flexibility in designing a complex system such as a polygeneration system could facilitate a brighter future for the system to be more applicable and widely used for other applications.

## 8. Summary

The evolution of energy systems has been a game changer for researchers designing a more effective, efficient and sustainable approach. Polygeneration is the answer to the problem of the complexity in a separate system. This study presented a technical review of SOFCs-based polygeneration systems implemented for residential applications. By reviewing polygeneration technology, this paper presented related technologies used to determine the prime mover, heat recovery systems, cooling units, hydrogen generation units and storage. The application and research trends of SOFC-based polygeneration systems were presented based on the number of publications since 1996. From the publication trend, the increased attention paid to polygeneration system cannot be denied and has become an essential key to implementing the system in modern energy planning. Potential research topics could be synthesizing the system configurations and components and designing the capacity, operating conditions and the operating strategies of the polygeneration system. Moreover, with further consideration of sustainability purposes, the technology of the polygeneration could be advantageous for generating cleaner and better energy for the environment and society. A guideline for designing a polygeneration system was presented with specific applications for residential areas to prepare for the future. However, the procedure can be applied for any other application and configuration that will become broader and widely used.

**Author Contributions:** F.R.: Conceptualization, writing; M.A.H.: Supervising, revising; H.M.: Supervising, editing; O.E.: revising, visualization. All authors have read and agreed to the published version of the manuscript.

**Funding:** This research is supported by Universiti Malaya under UM International Collaboration Grant (ST027-2022).

**Institutional Review Board Statement:** Not applicable.

**Informed Consent Statement:** Not applicable.

**Data Availability Statement:** Not applicable.

**Conflicts of Interest:** The authors declare no conflict of interest.

## References

1. Ramadhani, F.; Hussain, M.; Mokhlis, H.; Fazly, M.; Ali, J.M. Evaluation of solid oxide fuel cell based polygeneration system in residential areas integrating with electric charging and hydrogen fueling stations for vehicles. *Appl. Energy* **2019**, *238*, 1373–1388. [[CrossRef](#)]
2. Ramadhani, F.; Hussain, M.A.; Mokhlis, H.; Illias, H.A. Two-stage fuzzy-logic-based for optimal energy management strategy for SOFC/PV/TEG hybrid polygeneration system with electric charging and hydrogen fueling stations. *J. Renew. Sustain. Energy* **2021**, *13*, 024301. [[CrossRef](#)]
3. Luqman, M.; Ghat, I.; Maroof, M.; Lahlou, F.-Z.; Bicer, Y.; Al-Ansari, T. Application of the concept of a renewable energy based-polygeneration system for sustainable thermal desalination process—A thermodynamics' perspective. *Int. J. Energy Res.* **2020**, *44*, 12344–12362. [[CrossRef](#)]
4. Ramadhani, F.; Hussain, M.; Mokhlis, H.; Illias, H.A. Optimal heat recovery using photovoltaic thermal and thermoelectric generator for solid oxide fuel cell-based polygeneration system: Techno-economic and environmental assessments. *Appl. Therm. Eng.* **2020**, *181*, 116015. [[CrossRef](#)]
5. Giwa, A.; Yusuf, A.; Dindi, A.; Balogun, H.A. Polygeneration in desalination by photovoltaic thermal systems: A comprehensive review. *Renew. Sustain. Energy Rev.* **2020**, *130*, 109946. [[CrossRef](#)]
6. Rokni, M. Analysis of a polygeneration plant based on solar energy, dual mode solid oxide cells and desalination. *Int. J. Hydrogen Energy* **2019**, *44*, 19224–19243. [[CrossRef](#)]

7. Sahoo, U.; Kumar, R.; Pant, P.; Chaudhary, R. Development of an innovative polygeneration process in hybrid solar-biomass system for combined power, cooling and desalination. *Appl. Therm. Eng.* **2017**, *120*, 560–567. [[CrossRef](#)]
8. Villarruel-Jaramillo, A.; Pérez-García, M.; Cardemil, J.M.; Escobar, R.A. Review of Polygeneration Schemes with Solar Cooling Technologies and Potential Industrial Applications. *Energies* **2021**, *14*, 6450. [[CrossRef](#)]
9. Linde, L. Implementation of BECCS in a Polygeneration System—A Techno-Economic Feasibility Study in the District Heating Network of Stockholm. Master Thesis, KTH Industrial Engineering and Management, Stockholm, Sweden, 2016.
10. Lee, I.; Tester, J.W.; You, F. Systems analysis, design, and optimization of geothermal energy systems for power production and polygeneration: State-of-the-art and future challenges. *Renew. Sustain. Energy Rev.* **2019**, *109*, 551–577. [[CrossRef](#)]
11. Parraga, J.; Khalilpour, R.; Vassallo, A. Polygeneration with biomass-integrated gasification combined cycle process: Review and prospective. *Renew. Sustain. Energy Rev.* **2018**, *92*, 219–234. [[CrossRef](#)]
12. Rong, A.; Lahdelma, R. Role of polygeneration in sustainable energy system development challenges and opportunities from optimization viewpoints. *Renew. Sustain. Energy Rev.* **2016**, *53*, 363–372. [[CrossRef](#)]
13. Kwan, T.H.; Katsushi, F.; Shen, Y.; Yin, S.; Zhang, Y.; Kase, K.; Yao, Q. Comprehensive review of integrating fuel cells to other energy systems for enhanced performance and enabling polygeneration. *Renew. Sustain. Energy Rev.* **2020**, *128*, 109897. [[CrossRef](#)]
14. Cigolotti, V.; Genovese, M.; Fragiaco, P. Comprehensive Review on Fuel Cell Technology for Stationary Applications as Sustainable and Efficient Poly-Generation Energy Systems. *Energies* **2021**, *14*, 4963. [[CrossRef](#)]
15. Baroutaji, A.; Arjunan, A.; Robinson, J.; Wilberforce, T.; Abdelkareem, M.A.; Olabi, A.G. PEMFC Poly-Generation Systems: Developments, Merits, and Challenges. *Sustainability* **2021**, *13*, 11696. [[CrossRef](#)]
16. Department of Energy, USA. *Chapter 5: Increasing Efficiency of Building Systems and Technologies*; Department of Energy (DOE): Washington, DC, USA, 2015.
17. International Energy Agency, I. *Energy-Efficient Buildings: Heating and Cooling Equipment, in Technology Roadmap*; International Energy Agency (IEA): Paris, France, 2011.
18. Zaid, S.; Graham, P. The Need for Energy Efficiency Legislation in the Malaysian Building Sector. In Proceedings of the 3rd International Building Control Conference, Kuala Lumpur, Malaysia, 21 November 2013.
19. Wakui, T.; Yokoyama, R. Optimal sizing of residential SOFC cogeneration system for power interchange operation in housing complex from energy-saving viewpoint. *Energy* **2012**, *41*, 65–74. [[CrossRef](#)]
20. Wakui, T.; Wada, N.; Yokoyama, R. Feasibility study on combined use of residential SOFC cogeneration system and plug-in hybrid electric vehicle from energy-saving viewpoint. *Energy Convers. Manag.* **2012**, *60*, 170–179. [[CrossRef](#)]
21. Jana, K.; Ray, A.; Majoumerd, M.M.; Assadi, M.; De, S. Polygeneration as a future sustainable energy solution—A comprehensive review. *Appl. Energy* **2017**, *202*, 88–111. [[CrossRef](#)]
22. Palsson, J.; Selimovic, A.; Sjunnesson, L. Combined solid oxide fuel cell and gas turbine systems for efficient power and heat generation. *J. Power Sources* **2000**, *86*, 442–448. [[CrossRef](#)]
23. Chachuat, B.; Srinivasan, B.; Bonvin, D. Adaptation strategies for real-time optimization. *Comput. Chem. Eng.* **2009**, *33*, 1557–1567. [[CrossRef](#)]
24. Dicks, A.L.; Fellows, R.G.; Mescal, C.M.; Seymour, C. A study of SOFC–PEM hybrid systems. *J. Power Sources* **2000**, *86*, 501–506. [[CrossRef](#)]
25. Islam, S.; Dincer, I.; Yilbas, B.S. Development, analysis and assessment of solar energy-based multigeneration system with thermoelectric generator. *Energy Convers. Manag.* **2017**, *156*, 746–756. [[CrossRef](#)]
26. Zhang, H.; Kong, W.; Dong, F.; Xu, H.; Chen, B.; Ni, M. Application of cascading thermoelectric generator and cooler for waste heat recovery from solid oxide fuel cells. *Energy Convers. Manag.* **2017**, *148*, 1382–1390. [[CrossRef](#)]
27. Zhang, H.; Xu, H.; Chen, B.; Dong, F.; Ni, M. Two-stage thermoelectric generators for waste heat recovery from solid oxide fuel cells. *Energy* **2017**, *132*, 280–288. [[CrossRef](#)]
28. Islam, S.; Dincer, I.; Yilbas, B.S. Analysis and Assessment of A Biomass Energy-Based Multigeneration System with Thermoelectric Generators. *Energy Fuels* **2017**, *31*, 10901–10915. [[CrossRef](#)]
29. Li, Y.; Rezgoui, Y.; Zhu, H. District heating and cooling optimization and enhancement—Towards integration of renewables, storage and smart grid. *Renew. Sustain. Energy Rev.* **2017**, *72*, 281–294. [[CrossRef](#)]
30. Franco, A.; Versace, M. Multi-objective optimization for the maximization of the operating share of cogeneration system in District Heating Network. *Energy Convers. Manag.* **2017**, *139*, 33–44. [[CrossRef](#)]
31. Ameri, M.; Besharati, Z. Optimal design and operation of district heating and cooling networks with CCHP systems in a residential complex. *Energy Build.* **2016**, *110*, 135–148. [[CrossRef](#)]
32. Verrilli, F.; Parisio, A.; Glielmo, L. Stochastic model predictive control for optimal energy management of district heating power plants, in Decision and Control (CDC). In Proceedings of the 2016 IEEE 55th Conference, Las Vegas, NV, USA, 12–14 December 2016; pp. 807–812.
33. Gładysz, P.; Ziębik, A. Complex analysis of the optimal coefficient of the share of cogeneration in district heating systems. *Energy* **2013**, *62*, 12–22. [[CrossRef](#)]
34. Ahmadi, P. Modeling, Analysis and Optimization of Integrated Energy Systems for Multigeneration Purposes. In *Mechanical Engineering*; University of Ontario Institute of Technology: Oshawa, ON, Canada, 2013.
35. Irvine, J.T.S.; Connor, P. *Solid Oxide Fuels Cells: Facts and Figures: Past Present and Future Perspectives for SOFC Technologies*; Springer: London, UK, 2012.

36. Szega, M.; Żymelka, P. Thermodynamic and Economic Analysis of the Production of Electricity, Heat And Cold in the CHP Unit with the Absorption Chillers. *J. Energy Resour. Technol.* **2017**, *140*, 052002. [[CrossRef](#)]
37. Ciampi, G.; Rosato, A.; Scorpio, M.; Sibilio, S. Experimental analysis of a micro-trigeneration system composed of a micro-cogenerator coupled with an electric chiller. *Appl. Therm. Eng.* **2014**, *73*, 1309–1322. [[CrossRef](#)]
38. Palmero-Marrero, A.I.; Oliveira, A.C. Performance simulation of a solar-assisted micro-tri-generation system: Hotel case study. *Int. J. Low Carbon Technol.* **2011**, *6*, 309–317. [[CrossRef](#)]
39. Malico, I.; Carvalhinho, A.P.; Tenreiro, J. Design of a trigeneration system using a high-temperature fuel cell. *Int. J. Energy Res.* **2008**, *33*, 144–151. [[CrossRef](#)]
40. Liu, Y.; Leong, K. Numerical study of an internal-reforming solid oxide fuel cell and adsorption chiller co-generation system. *J. Power Sources* **2006**, *159*, 501–508. [[CrossRef](#)]
41. Sigurjonsson, H.; Clausen, L.R. Solution for the future smart energy system: A polygeneration plant based on reversible solid oxide cells and biomass gasification producing either electrofuel or power. *Appl. Energy* **2018**, *216*, 323–337. [[CrossRef](#)]
42. Sigarchian, S.G.; Malmquist, A.; Martin, V. The choice of operating strategy for a complex polygeneration system: A case study for a residential building in Italy. *Energy Convers. Manag.* **2018**, *163*, 278–291. [[CrossRef](#)]
43. Calise, F.; Figaj, R.D.; Vanoli, L. A novel polygeneration system integrating photovoltaic/thermal collectors, solar assisted heat pump, adsorption chiller and electrical energy storage: Dynamic and energy-economic analysis. *Energy Convers. Manag.* **2017**, *149*, 798–814. [[CrossRef](#)]
44. Jradi, M.; Riffat, S. Tri-generation systems: Energy policies, prime movers, cooling technologies, configurations and operation strategies. *Renew. Sustain. Energy Rev.* **2014**, *32*, 396–415. [[CrossRef](#)]
45. Al Moussawi, H.; Fardoun, F.; Louahia-Gualous, H. Review of tri-generation technologies: Design evaluation, optimization, decision-making, and selection approach. *Energy Convers. Manag.* **2016**, *120*, 157–196. [[CrossRef](#)]
46. Bernard, A. Micro Combined Heat and Power Operating on Renewable Energy for Residential Building. Ph.D. Thesis, CEP-Centre Energétique et Procédés, Paris, France, 2008.
47. Akikur, R.; Saidur, R.; Ping, H.; Ullah, K. Performance analysis of a co-generation system using solar energy and SOFC technology. *Energy Convers. Manag.* **2014**, *79*, 415–430. [[CrossRef](#)]
48. Elmer, T.; Worall, M.; Wu, S.; Riffat, S.B. Fuel cell technology for domestic built environment applications: State of-the-art review. *Renew. Sustain. Energy Rev.* **2015**, *42*, 913–931. [[CrossRef](#)]
49. Ellamla, H.R.; Staffell, I.; Bujlo, P.; Pollet, B.G.; Pasupathi, S. Current status of fuel cell based combined heat and power systems for residential sector. *J. Power Sources* **2015**, *293*, 312–328. [[CrossRef](#)]
50. US DOE. *Energy Efficiency and Renewable Energy*; US DOE: Washington, DC, USA, 2007.
51. Entchev, E.; Yang, L.; Ghorab, M.; Lee, E. Simulation of hybrid renewable microgeneration systems in load sharing applications. *Energy* **2013**, *50*, 252–261. [[CrossRef](#)]
52. Oland, C.B. *Guide to Low-Emission Boiler and Combustion Equipment Selection*; The Laboratory: Oak Ridge, TN, USA, 2002.
53. Oland, C.B. *Guide to Combined Heat and Power Systems for Boiler Owners and Operators*; United States Department of Energy: Washington, DC, USA, 2004.
54. Bensaid, S.; Brignone, M.; Ziggotti, A.; Specchia, S. High efficiency Thermo-Electric power generator. *Int. J. Hydrogen Energy* **2012**, *37*, 1385–1398. [[CrossRef](#)]
55. Terayama, T.; Nagata, S.; Tanaka, Y.; Momma, A.; Kato, T.; Yamamoto, A. Improvement of SOFC System Efficiency by Incorporating Thermoelectric Power Generation Heat Exchanger. *ECS Trans.* **2013**, *57*, 2627–2636. [[CrossRef](#)]
56. Sonar, D.; Soni, S.; Sharma, D. Micro-trigeneration for energy sustainability: Technologies, tools and trends. *Appl. Therm. Eng.* **2014**, *71*, 790–796. [[CrossRef](#)]
57. Siyal, S.H.; Mentis, D.; Howells, M. Economic analysis of standalone wind-powered hydrogen refueling stations for road transport at selected sites in Sweden. *Int. J. Hydrogen Energy* **2015**, *40*, 9855–9865. [[CrossRef](#)]
58. Sharma, S.; Ghoshal, S.K. Hydrogen the future transportation fuel: From production to applications. *Renew. Sustain. Energy Rev.* **2015**, *43*, 1151–1158. [[CrossRef](#)]
59. Stojić, D.L.; Marčeta, M.P.; Sovilj, S.P.; Miljanić, Š.S. Hydrogen generation from water electrolysis—Possibilities of energy saving. *J. Power Sources* **2003**, *118*, 315. [[CrossRef](#)]
60. Dunn, S. Hydrogen futures: Toward a sustainable energy system. *Int. J. Hydrogen Energy* **2002**, *27*, 235–264. [[CrossRef](#)]
61. Rabbani, H.; Dincer, I.; Rahnamayan, S. A novel multigenerational hydrogen production system: Performance evaluation. *Int. J. Hydrogen Energy* **2017**, *42*, 12888–12895. [[CrossRef](#)]
62. Sarhaddi, F.; Farahat, S.; Ajam, H.; Behzadmehr, A.; Adeli, M.M. An improved thermal and electrical model for a solar photovoltaic thermal (PV/T) air collector. *Appl. Energy* **2010**, *87*, 2328–2339. [[CrossRef](#)]
63. Suberu, M.Y.; Mustafa, M.W.; Bashir, N. Energy storage systems for renewable energy power sector integration and mitigation of intermittency. *Renew. Sustain. Energy Rev.* **2014**, *35*, 499–514. [[CrossRef](#)]
64. Mahlia, T.; Saktisahdan, T.; Jannifar, A.; Hasan, M.; Matseelar, H. A review of available methods and development on energy storage; technology update. *Renew. Sustain. Energy Rev.* **2014**, *33*, 532–545. [[CrossRef](#)]
65. New Mexico Environment Department. *Air-Water Temperature Correlation*; Surface Water Quality Bureau: Santa Fe, NM, USA, 2011.
66. Ang, S.M.C.; Fraga, E.S.; Brandon, N.P.; Samsatli, N.J.; Brett, D.J. Fuel cell systems optimisation—Methods and strategies. *Int. J. Hydrogen Energy* **2011**, *36*, 14678–14703. [[CrossRef](#)]



67. Isa, Z.M.; Rahim, N.A. PEM fuel cell model parameters optimization using modified particle swarm optimization algorithm. In Proceedings of the IEEE Conference on Clean Energy and Technology (CEAT), Langkawi, Malaysia, 18–20 November 2013.
68. Ramadhani, F.; Abu Bakar, K.; Shafer, M.G. Optimization of standalone street light system with consideration of lighting control. In Proceedings of the 2013 International Conference on Technological Advances in Electrical, Electronics and Computer Engineering (TAECE), Konya, Turkey, 9–11 May 2013.
69. Ramadhani, F.; Abu Bakar, K.; Hussain, M.; Erixno, O.; Nazir, R. Optimization with traffic-based control for designing standalone streetlight system: A case study. *Renew. Energy* **2016**, *105*, 149–159. [[CrossRef](#)]
70. Choudhury, A.; Chandra, H.; Arora, A. Application of solid oxide fuel cell technology for power generation—A review. *Renew. Sustain. Energy Rev.* **2013**, *20*, 430–442. [[CrossRef](#)]
71. Mohamad, H.; Abu Bakar, A.; Ping, H.; Mokhlis, H. An adaptive controller of hydro generators for smart grid application in Malaysia. In Proceedings of the 2010 International Conference on Power System Technology, Hangzhou, China, 24–28 October 2010; pp. 1–6.
72. Burer, M.; Tanaka, K.; Favrat, D.; Yamada, K. Multi-criteria optimization of a district cogeneration plant integrating a solid oxide fuel cell–gas turbine combined cycle, heat pumps and chillers. *Energy* **2003**, *28*, 497–518. [[CrossRef](#)]
73. Akikur, R.K.; Saidur, R.; Ullah, K.R.; Hajimolana, S.A.; Ping, H.W.; Hussain, M.A. Economic feasibility analysis of a solar energy and solid oxide fuel cell-based cogeneration system in Malaysia. *Clean Technol. Environ. Policy* **2015**, *18*, 669–687. [[CrossRef](#)]
74. Mahlia, T.M.I.; Chan, P. Life cycle cost analysis of fuel cell based cogeneration system for residential application in Malaysia. *Renew. Sustain. Energy Rev.* **2011**, *15*, 416–426. [[CrossRef](#)]
75. Al Moussawi, H.; Fardoun, F.; Louahlia, H. 4-E based optimal management of a SOFC-CCHP system model for residential applications. *Energy Convers. Manag.* **2017**, *151*, 607–629. [[CrossRef](#)]
76. *Eleventh Malaysia Plan, Strategy Paper 17: Sustainable Usage of Energy to Support Growth*; Federal Government Administrative Centre: Putrajaya, Malaysia, 2017.
77. Genovese, M.; Fragiaco, P. Hydrogen station evolution towards a poly-generation energy system. *Int. J. Hydrogen Energy* **2021**, *47*, 12264–12280. [[CrossRef](#)]
78. Richardson, I.A.; Fisher, J.T.; Frome, P.E.; Smith, B.O.; Guo, S.; Chanda, S.; McFeely, M.S.; Miller, A.M.; Leachman, J.W. Low-cost, transportable hydrogen fueling station for early market adoption of fuel cell electric vehicles. *Int. J. Hydrogen Energy* **2015**, *40*, 8122–8127. [[CrossRef](#)]
79. Wakui, T.; Kawayoshi, H.; Yokoyama, R. Optimal structural design of residential power and heat supply devices in consideration of operational and capital recovery constraints. *Appl. Energy* **2016**, *163*, 118–133. [[CrossRef](#)]
80. Atsonios, K.; Samlis, C.; Manou, K.; Nikolopoulos, A.; Sfetsioris, K.; Mitsotakis, A.; Grammelis, P. Technical assessment of LNG based polygeneration systems for non-interconnected island cases using SOFC. *Int. J. Hydrogen Energy* **2020**, *46*, 4827–4843. [[CrossRef](#)]
81. Holagh, S.G.; Haghghi, M.A.; Mohammadi, Z.; Chitsaz, A. Exergoeconomic and environmental investigation of an innovative poly-generation plant driven by a solid oxide fuel cell for production of electricity, cooling, desalinated water, and hydrogen. *Int. J. Energy Res.* **2020**, *44*, 10126–10154. [[CrossRef](#)]
82. Li, M.; Zhuang, Y.; Song, M.; Li, W.; Du, J. Techno-economic and carbon footprint feasibility assessment for polygeneration process of carbon-capture coal-to-methanol/power and molten carbonate fuel cell. *Energy Convers. Manag.* **2021**, *235*, 114015. [[CrossRef](#)]
83. Wang, J.; Yang, Y.; Mao, T.; Sui, J.; Jin, H. Life cycle assessment (LCA) optimization of solar-assisted hybrid CCHP system. *Appl. Energy* **2015**, *146*, 38–52. [[CrossRef](#)]
84. Mago, P.J.; Fumo, N.; Chamra, L.M. Performance analysis of CCHP and CHP systems operating following the thermal and electric load. *Int. J. Energy Res.* **2009**, *33*, 852–864. [[CrossRef](#)]
85. Mago, P.; Chamra, L.; Ramsay, J. Micro-combined cooling, heating and power systems hybrid electric-thermal load following operation. *Appl. Therm. Eng.* **2010**, *30*, 800–806. [[CrossRef](#)]
86. Smith, A.; Luck, R.; Mago, P.J. Analysis of a combined cooling, heating, and power system model under different operating strategies with input and model data uncertainty. *Energy Build.* **2010**, *42*, 2231–2240. [[CrossRef](#)]
87. Zheng, C.; Wu, J.; Zhai, X. A novel operation strategy for CCHP systems based on minimum distance. *Appl. Energy* **2014**, *128*, 325–335. [[CrossRef](#)]
88. Kavvadias, K.; Maroulis, Z. Multi-objective optimization of a trigeneration plant. *Energy Policy* **2010**, *38*, 945–954. [[CrossRef](#)]
89. Hajabdollahi, H.; Ganjehkaviri, A.; Jaafar, M.N.M. Assessment of new operational strategy in optimization of CCHP plant for different climates using evolutionary algorithms. *Appl. Therm. Eng.* **2015**, *75*, 468–480. [[CrossRef](#)]
90. Basrawi, F.; Yamada, T.; Obara, S. Economic and environmental based operation strategies of a hybrid photovoltaic–microgas turbine trigeneration system. *Appl. Energy* **2014**, *121*, 174–183. [[CrossRef](#)]
91. Kavvadias, K.; Tosios, A.; Maroulis, Z. Design of a combined heating, cooling and power system: Sizing, operation strategy selection and parametric analysis. *Energy Convers. Manag.* **2010**, *51*, 833–845. [[CrossRef](#)]
92. Martínez-Lera, S.; Ballester, J. Analysis and sizing of thermal energy storage in combined heating, cooling and power plants for buildings. *Appl. Energy* **2013**, *106*, 127–142. [[CrossRef](#)]
93. Ondeck, A.D.; Edgar, T.F.; Baldea, M. Optimal operation of a residential district-level combined photovoltaic/natural gas power and cooling system. *Appl. Energy* **2015**, *156*, 593–606. [[CrossRef](#)]

94. Adam, A.; Fraga, E.S.; Brett, D.J. Modelling and Optimisation in Terms of CO<sub>2</sub> Emissions of a Solid Oxide Fuel Cell based Micro-CHP System in a Four Bedroom House in London. *Energy Procedia* **2013**, *42*, 201–209. [[CrossRef](#)]
95. Hawkes, A.; Leach, M. Cost-effective operating strategy for residential micro-combined heat and power. *Energy* **2007**, *32*, 711–723. [[CrossRef](#)]
96. Hawkes, A.; Aguiar, P.; Croxford, B.; Leach, M.; Adjiman, C.; Brandon, N. Solid oxide fuel cell micro combined heat and power system operating strategy: Options for provision of residential space and water heating. *J. Power Sources* **2007**, *164*, 260–271. [[CrossRef](#)]
97. Taghavifar, H.; Anvari, S.; Saray, R.K.; Khalilarya, S.; Jafarmadar, S. Towards modeling of combined cooling, heating and power system with artificial neural network for exergy destruction and exergy efficiency prognostication of tri-generation components. *Appl. Therm. Eng.* **2015**, *89*, 156–168. [[CrossRef](#)]
98. Anvari, S.; Taghavifar, H.; Saray, R.K.; Khalilarya, S.; Jafarmadar, S. Implementation of ANN on CCHP system to predict trigeneration performance with consideration of various operative factors. *Energy Convers. Manag.* **2015**, *101*, 503–514. [[CrossRef](#)]
99. Entchev, E. Residential fuel cell energy systems performance optimization using “soft computing” techniques. *J. Power Sources* **2003**, *118*, 212–217. [[CrossRef](#)]
100. Li, M.; Mu, H.; Li, N.; Ma, B. Optimal design and operation strategy for integrated evaluation of CCHP (combined cooling heating and power) system. *Energy* **2016**, *99*, 202–220. [[CrossRef](#)]
101. Shaneb, O.A.; Taylor, P.C.; Coates, G. Real time operation of  $\mu$ CHP systems using fuzzy logic. *Energy Build.* **2012**, *55*, 141–150. [[CrossRef](#)]
102. Chen, J.M.P.; Ni, M. Economic analysis of a solid oxide fuel cell cogeneration/trigeneration system for hotels in Hong Kong. *Energy Build.* **2014**, *75*, 160–169. [[CrossRef](#)]
103. Weber, C.; Marechal, F.; Favrat, D.; Kraines, S. Optimization of an SOFC-based decentralized polygeneration system for providing energy services in an office-building in Tōkyō. *Appl. Therm. Eng.* **2006**, *26*, 1409–1419. [[CrossRef](#)]
104. Antonucci, V.; Brunaccini, G.; De Pascale, A.; Ferraro, M.; Melino, F.; Orlandini, V.; Sergi, F. Integration of  $\mu$ -SOFC Generator and ZEBRA Batteries for Domestic Application and Comparison with other  $\mu$ -CHP Technologies. *Energy Procedia* **2015**, *75*, 999–1004. [[CrossRef](#)]
105. Nataf, K.; Bradley, T.H. An economic comparison of battery energy storage to conventional energy efficiency technologies in Colorado manufacturing facilities. *Appl. Energy* **2016**, *164*, 133–139. [[CrossRef](#)]
106. Jabari, F.; Nojavan, S.; Ivatloo, B.M.; Sharifian, M.B. Optimal short-term scheduling of a novel tri-generation system in the presence of demand response programs and battery storage system. *Energy Convers. Manag.* **2016**, *122*, 95–108. [[CrossRef](#)]
107. Isa, N.M.; Das, H.S.; Tan, C.W.; Yatim, A.; Lau, K.Y. A techno-economic assessment of a combined heat and power photo-voltaic/fuel cell/battery energy system in Malaysia hospital. *Energy* **2016**, *112*, 75–90. [[CrossRef](#)]
108. Misra, S.; Satyaprasad, G.R.K.D.; Mahapatra, S.S.; Mohanty, A.; Biswal, S.R.; Dora, A. Design of Fuel cell based Cogeneration systems: An approach for battery less Solar PV system. *Int. Res. J. Eng. Technol.* **2016**, *3*, 47–50.
109. Fragiaco, P.; Lucarelli, G.; Genovese, M.; Florio, G. Multi-objective optimization model for fuel cell-based poly-generation energy systems. *Energy* **2021**, *237*, 121823. [[CrossRef](#)]
110. Cardona, E.; Piacentino, A. A methodology for sizing a trigeneration plant in mediterranean areas. *Appl. Therm. Eng.* **2003**, *23*, 1665–1680. [[CrossRef](#)]
111. Baghernejad, A.; Yaghoobi, M.; Jafarpur, K. Optimum power performance of a new integrated SOFC-trigeneration system by multi-objective exergoeconomic optimization. *Int. J. Electr. Power Energy Syst.* **2015**, *73*, 899–912. [[CrossRef](#)]
112. Arcuri, P.; Beraldi, P.; Florio, G.; Fragiaco, P. Optimal design of a small size trigeneration plant in civil users: A MINLP (Mixed Integer Non Linear Programming Model). *Energy* **2015**, *80*, 628–641. [[CrossRef](#)]
113. Elmer, T. *A Novel SOFC Tri-Generation System for Building Applications*; University of Nottingham: Nottingham, UK, 2015.
114. Martínez-Lera, S.; Ballester, J. A novel method for the design of CHCP (combined heat, cooling and power) systems for buildings. *Energy* **2010**, *35*, 2972–2984. [[CrossRef](#)]
115. Windeknecht, M.; Tzscheuschler, P. Optimization of the Heat Output of High Temperature Fuel Cell Micro-CHP in Single Family Homes. *Energy Procedia* **2015**, *78*, 2160–2165. [[CrossRef](#)]
116. Liso, V.; Zhao, Y.; Yang, W.; Nielsen, M.P. Modelling of a Solid Oxide Fuel Cell CHP System Coupled with a Hot Water Storage Tank for a Single Household. *Energies* **2015**, *8*, 2211–2229. [[CrossRef](#)]
117. Facci, A.L.; Cigolotti, V.; Jannelli, E.; Ubertaini, S. Technical and economic assessment of a SOFC-based energy system for combined cooling, heating and power. *Appl. Energy* **2017**, *192*, 563–574. [[CrossRef](#)]
118. Wang, J.-J.; Jing, Y.-Y.; Zhang, C.-F. Optimization of capacity and operation for CCHP system by genetic algorithm. *Appl. Energy* **2010**, *87*, 1325–1335. [[CrossRef](#)]
119. Guo, L.; Liu, W.J.; Cai, J.J.; Hong, B.W.; Wang, C.S. A two-stage optimal planning and design method for combined cooling, heat and power microgrid system. *Energy Convers. Manag.* **2013**, *74*, 433–445. [[CrossRef](#)]
120. Wang, J.; Zhai, Z.; Jing, Y.; Zhang, C. Optimization design of BCHP system to maximize to save energy and reduce environmental impact. *Energy* **2010**, *35*, 3388–3398. [[CrossRef](#)]
121. Wang, J.; Zhai, Z.; Jing, Y.; Zhang, C. Particle swarm optimization for redundant building cooling heating and power system. *Appl. Energy* **2010**, *87*, 3668–3679. [[CrossRef](#)]

122. Wakui, T.; Yokoyama, R. Impact analysis of sampling time interval and battery installation on optimal operational planning of residential cogeneration systems without electric power export. *Energy* **2015**, *81*, 120–136. [[CrossRef](#)]
123. Chen, X.; Wu, Q.; Li, Z.; Wang, M. Investigation of a CHP-EES based on Dymola. In Proceedings of the 2015 IEEE International Conference on Signal Processing, Communications and Computing (ICSPCC), Ningbo, China, 19–22 September 2015.
124. Antonucci, V.; Branchini, L.; Brunaccini, G.; De Pascale, A.; Ferraro, M.; Melino, F.; Orlandini, V.; Sergi, F. Thermal integration of a SOFC power generator and a Na–NiCl<sub>2</sub> battery for CHP domestic application. *Appl. Energy* **2017**, *185*, 1256–1267. [[CrossRef](#)]
125. Hajabdollahi, Z.; Fu, P.-F. Multi-objective based configuration optimization of SOFC–GT cogeneration plant. *Appl. Therm. Eng.* **2016**, *112*, 549–559. [[CrossRef](#)]
126. Wang, J.; Wu, J.; Zheng, C. Analysis of tri-generation system in combined cooling and heating mode. *Energy Build.* **2014**, *72*, 353–360. [[CrossRef](#)]
127. Kazemipoor, P.; Dorer, V.; Ommi, F. Evaluation of hydrogen and methane-fuelled solid oxide fuel cell systems for residential applications: System design alternative and parameter study. *Int. J. Hydrogen Energy* **2009**, *34*, 8630–8644. [[CrossRef](#)]
128. Kazemipoor, P.; Dorer, V.; Weber, A. Modelling and evaluation of building integrated SOFC systems. *Int. J. Hydrogen Energy* **2011**, *36*, 13241–13249. [[CrossRef](#)]
129. Perdikaris, N.; Panopoulos, K.; Hofmann, P.; Spyrikis, S.; Kakaras, E. Design and exergetic analysis of a novel carbon free tri-generation system for hydrogen, power and heat production from natural gas, based on combined solid oxide fuel and electrolyser cells. *Int. J. Hydrogen Energy* **2010**, *35*, 2446–2456. [[CrossRef](#)]
130. Braun, R.; Kazemipoor, P. *Application of SOFCs in Combined Heat, Cooling, and Power Systems. Solid Oxide Fuel Cells: From Materials to System Modeling*; Ni, M., Zhao, T.S., Eds.; Energy and Environment Series; Royal Society of Chemistry: London, UK, 2013.
131. Adams, S.; Klobodu, E.K.M.; Apio, A. Renewable and non-renewable energy, regime type and economic growth. *Renew. Energy* **2018**, *125*, 755–767. [[CrossRef](#)]
132. Baul, T.; Datta, D.; Alam, A. A comparative study on household level energy consumption and related emissions from renewable (biomass) and non-renewable energy sources in Bangladesh. *Energy Policy* **2018**, *114*, 598–608. [[CrossRef](#)]
133. Narayan, S.; Doytch, N. An investigation of renewable and non-renewable energy consumption and economic growth nexus using industrial and residential energy consumption. *Energy Econ.* **2017**, *68*, 160–176. [[CrossRef](#)]
134. Rosato, A.; Sibilio, S.; Ciampi, G.; Entchev, E.; Ribberink, H. Energy, Environmental and Economic Effects of Electric Vehicle Charging on the Performance of a Residential Building-integrated Micro-trigeneration System. *Energy Procedia* **2017**, *111*, 699–709. [[CrossRef](#)]
135. Tie, C.H.; Gan, C.K.; Ibrahim, K.A. The impact of electric vehicle charging on a residential low voltage distribution network in Malaysia. In Proceedings of the 2014 IEEE Innovative Smart Grid Technologies-Asia (ISGT Asia), Kuala Lumpur, Malaysia, 20 May 2014.
136. Wakui, T.; Wada, N.; Yokoyama, R. Energy-saving effect of a residential polymer electrolyte fuel cell cogeneration system combined with a plug-in hybrid electric vehicle. *Energy Convers. Manag.* **2014**, *77*, 40–51. [[CrossRef](#)]
137. Aviso, K.B.; Tan, R.R. Fuzzy P-graph for optimal synthesis of cogeneration and trigeneration systems. *Energy* **2018**, *154*, 258–268. [[CrossRef](#)]
138. Andiappan, V.; Ng, D.K. Synthesis of tri-generation systems: Technology selection, sizing and redundancy allocation based on operational strategy. *Comput. Chem. Eng.* **2016**, *91*, 380–391. [[CrossRef](#)]
139. Tan, L.; Yang, C.; Zhou, N. Synthesis/design optimization of SOFC–PEM hybrid system under uncertainty. *Chin. J. Chem. Eng.* **2015**, *23*, 128–137. [[CrossRef](#)]