






Article

# Experimental Investigation of Diesel Engine Performance, Combustion and Emissions Using a Novel Series of Dioctyl Phthalate (DOP) Biofuels Derived from Microalgae

Farhad M. Hossain <sup>1,2,\*</sup> , Md. Nurun Nabi <sup>3</sup>, Md. Mostafizur Rahman <sup>4</sup>, Saiful Bari <sup>5</sup>, Thuy Chu Van <sup>1</sup> , S. M. Ashrafur Rahman <sup>1</sup> , Thomas J. Rainey <sup>1</sup> , Timothy A. Bodisco <sup>6</sup>, Kabir Suara <sup>1</sup> , Zoran Ristovski <sup>1</sup> and Richard J. Brown <sup>1</sup>

<sup>1</sup> Biofuel Engine Research Facilities, Queensland University of Technology, Brisbane, QLD 4001, Australia; thuy.chuvan@qut.edu.au (T.C.V.); s2.rahman@qut.edu.au (S.M.A.R.); t.rainey@qut.edu.au (T.J.R.); k.suara@qut.edu.au (K.S.); z.ristovski@qut.edu.au (Z.R.); richard.brown@qut.edu.au (R.J.B.)

<sup>2</sup> Green Distillation Technologies (GDT) Corporation Limited, VIC 3142, Australia

<sup>3</sup> School of Engineering and Technology, Central Queensland University, Perth, WA 6000, Australia; m.nabi@cqu.edu.au

<sup>4</sup> School of Mechanical, Aerospace and Automotive Engineering, Coventry University, Coventry CV1 2JH, UK; ad2536@coventry.ac.uk

<sup>5</sup> School of Engineering, University of South Australia, Mawson Lakes, SA 5095, Australia; saiful.bari@unisa.edu.au

<sup>6</sup> School of Engineering, Deakin University, Geelong, VIC 3216, Australia; t.bodisco@deakin.edu.au

\* Correspondence: mfarhad03@yahoo.com or mdfarhad.hossain@hdr.qut.edu.au

Received: 16 April 2019; Accepted: 17 May 2019; Published: 22 May 2019



**Abstract:** Physico-chemical properties of microalgae biodiesel depend on the microalgae species and oil extraction method. Dioctyl phthalate (DOP) is a clear, colourless and viscous liquid as a plasticizer. It is used in the processing of polyvinyl chloride (PVC) resin and polymers. A new potential biofuel, hydrothermally liquefied microalgae bio-oil can contain nearly 11% (by mass) of DOP. This study investigated the feasibility of using up to 20% DOP blended in 80% diesel fuel (*v/v*) in an existing diesel engine, and assessed the performance and exhaust emissions. Despite reasonable differences in density, viscosity, surface tension, and boiling point, blends of DOP and diesel fuel were found to be entirely miscible and no separation was observed at any stage during prolonged miscibility tests. The engine test study found a slight decrease in peak cylinder pressure, brake, and indicated mean effective pressure, indicated power, brake power, and indicated and brake thermal efficiency with DOP blended fuels, where the specific fuel consumption increased. This is due to the presence of 16.4% oxygen in neat DOP, responsible for the relatively lower heating value, compared to that of diesel. The emission tests revealed a slight increase in nitrogen oxides (NO<sub>x</sub>) and carbon monoxide (CO) emissions from DOP blended fuels. However, particulate matter (PM) emissions were lower from DOP blended fuels, although some inconsistency in particle number (PN) was present among different engine loads.

**Keywords:** DOP; biofuels; microalgae; engine performance; NO<sub>x</sub>; PM; PN

## 1. Introduction

The search for alternative fuels has been accelerated in recent years owing to increasing energy demands and limited fossil fuel reserves [1,2]. Globally, the transportation sector consumes nearly 60% of the total oil consumption [3]. The demand for transport fuel is also growing rapidly, and this growth

is mostly driven by the countries outside the Organization of Economic Cooperation and Development (OECD). It is estimated that the energy demand in commercial transportation will increase by about 75% by 2040. Therefore, demand for heavy-duty fuel (diesel) will rise by ~85%, while gasoline demand will fall ~10% over the same period [4]. The current trend in the vehicle market also suggests that the growing popularity of diesel vehicles, especially in the Asia Pacific and Europe regions, which will further drive diesel fuel demand [5,6]. The market share of diesel vehicles has already exceeded 60% in some European countries such as France and Belgium [4].

Public concern over greenhouse gas emissions, human health and environmental impacts are significant drivers for alternative renewable sources of energy research. Globally, the transportation sector is responsible for nearly 30% of the greenhouse gas emissions [7]. Numerous studies have already revealed the deleterious effect of these pollutants on human health and the environment [8]. Therefore alternatives to diesel fuel are needed that can reduce the overall emissions from diesel engines, including its greenhouse gas loading.

Biodiesel is considered as a promising alternative to petro-diesel, not only for its renewability but also for its emissions benefits [9]. The well-to-wheel CO<sub>2</sub> emissions from biodiesel have been shown to be 50–80% lower than diesel, depending upon the feed stocks and production process [10]. There is overwhelming evidence in the literature that CO, HC and PM emissions from biodiesel are significantly less than diesel [11,12]. Though NO<sub>x</sub> and Particle Number (PN) from biodiesel are usually shown to be higher in the reported literature [13]. However, some studies, suggest that both NO<sub>x</sub> and solid PN emissions from biodiesel can be reduced by controlling the physical-chemical properties [14].

Biodiesel can be produced from a wide variety of sources. Among them, microalgae has been shown to be capable of meeting growing global biodiesel demand in the near future. However, the extraction of oil from microalgae efficiently and cost-effectively is still a major challenge to commercialize biodiesel derived from microalgae [2]. Compounding the complexity, the physicochemical properties of microalgae biodiesel also depend on the microalgae species and oil extraction method, which eventually influence their combustion and emissions behavior [15].

Hydrothermal liquefaction is a developing technology to extract bio-oil from microalgae [16–18]. This extracted bio-oil can be a potential source for microalgae biodiesel. Our previous studies found nearly 11% dioctyl phthalate (DOP) in hydrothermally liquefied microalgal bio-oil [19]. DOP is a heavier distillate of crude petroleum oil and is a clear, colorless, and viscous liquid widely used as general purpose plasticizer. This study investigated the feasibility of blending a new fuel DOP with diesel, determining the physico-chemical properties of diesel-DOP blends, and testing their engine performance and emissions in a common-rail turbocharged diesel engine. The novelty of this study is to investigate the effect of DOP blends on diesel engine performance and emission. To the best of the authors' knowledge, no study has examined the influence of DOP addition to diesel fuel on engine performance and emissions.

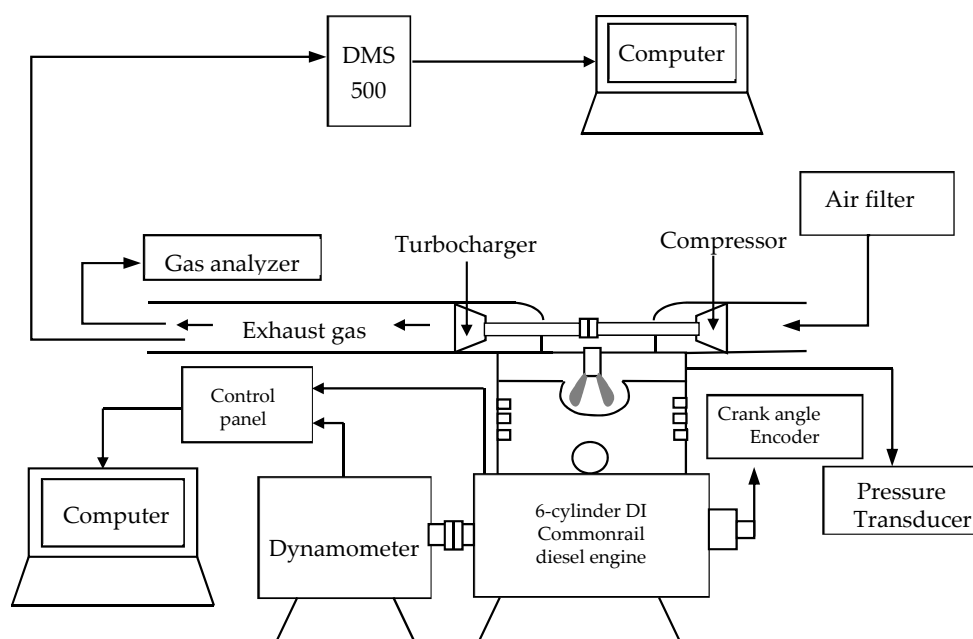
## 2. Materials and Methods

The following sections describe in detail the experimental procedure and physio-chemical properties of DOP fuels. Experiments were conducted on a EURO III heavy-duty diesel engine coupled to a water brake dynamometer. The specification of the test engine is given in Table 1. The engine was operated at the speed where peak torque occurs (1500 rpm) with four different loads (25%, 50%, 75%, and 100% of full load). Maximum load at any particular engine speed depends upon the type of fuel used; therefore for each fuel, maximum load was determined when the engine was at full throttle at 1500 rpm. The other loads (25%, 50%, and 75%) for that particular fuel/fuel blend were calculated and the throttle position was set to achieve the respective load. The combustion pressure sensor Kistler (6053CC60) sampled at 200 kHz was used to measure the in-cylinder pressure and a water type dynamometer was used to measure the brake power of the engine. Further details of the instrumentation for combustion diagnosis and engine performance can be found in Hossain et al. [17].

**Table 1.** Engine specifications.

Model	Cummins ISBe220 31
Cylinders	6 in-line
Capacity (dm <sup>3</sup> )	5.9
Bore × Stroke (mm)	102 × 120
Maximum power (kW/rpm)	162/2500
Maximum torque (Nm/rpm)	820/1500
Compression ratio	17.3
Aspiration	Turbocharged and after cooled
Fuel Injection	Common rail
Emissions certification	Euro III

A partial flow dilution tunnel was used to sample raw exhaust diluted with particle free compressed air. A Dekati diluter was connected in series with the dilution tunnel to increase the dilution ratio further. A HEPA filter was used to provide particle free air for the diluters. The purpose of the dilution was to bring down the temperature as well as the concentration of gases and PM within the measuring range of the instruments. The diluted exhaust was then passed to different gaseous and particle measuring instruments. A CAI 600 series CO<sub>2</sub> analyzer and CAI 600 series CLD NO<sub>x</sub> analyzer were used to measure the CO<sub>2</sub> and NO<sub>x</sub> concentration directly from the raw engine exhaust. A second CO<sub>2</sub> meter (Sable, CA-10) connected via a three-way valve between the two diluters was used to record the CO<sub>2</sub> concentration from the diluted exhaust. Background corrected CO<sub>2</sub> was used as a tracer gas to calculate the dilution ratio for each stage. After the first stage dilution, PM<sub>2.5</sub> emissions were measured by a TSI DustTrak (Model 8530). DustTrak readings were converted into diesel particles using the tapered element oscillating microbalance to DustTrak correlation, which is published by Jamriska et al. [20]. A Cambustion DMS500 was used to measured the particle number size distribution. The engine exhausts were directed to a fast particle sampler (DMS500), where particle data were recorded. The DMS can record the particles from 5 nm to 1.0 µm. Further details of the exhaust measurement system can be found in Rahman, Stevanovic [21]. Figure 1 shows the schematic diagram of the experimental set up.

**Figure 1.** Schematic diagram of the experimental set up [17].

An ultra-low sulphur diesel ( $\leq 15$  ppm) was used as a reference fuel. Two diesel-dioctyl phthalate blends namely 90D10DOP (blends of 90% diesel and 10% DOP) and 80D20DOP (blends of 80% diesel

and 20% DOP) were used as test fuels for this study. Some important properties of the used fuels related to combustion and emissions are shown in Table 2. The density and surface tension of both diesel-DOP blends are comparable with the reference diesel, these properties for pure DOP were slightly higher than the reference diesel, however, given the low blending ratio the influence on the final properties were small. The viscosity, surface tension, flash point, and heating value for pure DOP are reasonably higher than the reference diesel. Therefore, these properties for the blends were also higher. Regarding elemental composition, the reference diesel contains nearly 18% more carbon than pure DOP, where the hydrogen contents in both fuels are comparable. Pure DOP composed of 16.4% oxygen, despite having no oxygen in the reference diesel, 90D10DOP and 80D20DOP blends contain 1.6% and 3.28% oxygen, respectively.

**Table 2.** Properties of tested fuels [19].

Properties	Methods	Diesel	DOP	90D10DOP	80D20DOP
<sup>1</sup> Density, at 20 °C, kg/m <sup>3</sup>	ASTM D4052	840	960	850	860
<sup>1</sup> Kinematic Viscosity, m <sup>2</sup> /s at 40 °C	ASTM D445	2.66	27.40	5.13	7.60
<sup>1</sup> HHV, MJ/kg	ASTM D240	45.64	35.70	44.65	43.65
<sup>2</sup> LHV, MJ/kg	-	43.95	33.71	41.92	41.01
<sup>3,4</sup> Flash point (Close cup), °C	ASTM D93	67.5	207	81.45	95.4
<sup>1</sup> Surface Tension, mN/m	-	26.77	30.55	27.15	27.53
<sup>2</sup> Carbon, (m/m %)	-	91.66	73.79	89.87	88.09
<sup>2</sup> Hydrogen, (m/m %)	-	8.34	9.81	8.49	8.63
<sup>2</sup> Oxygen, (m/m %)	-	0	16.4	1.64	3.28
<sup>4,5</sup> Cetane index	ASTM D4737A	51.74	48	51.37	50.99

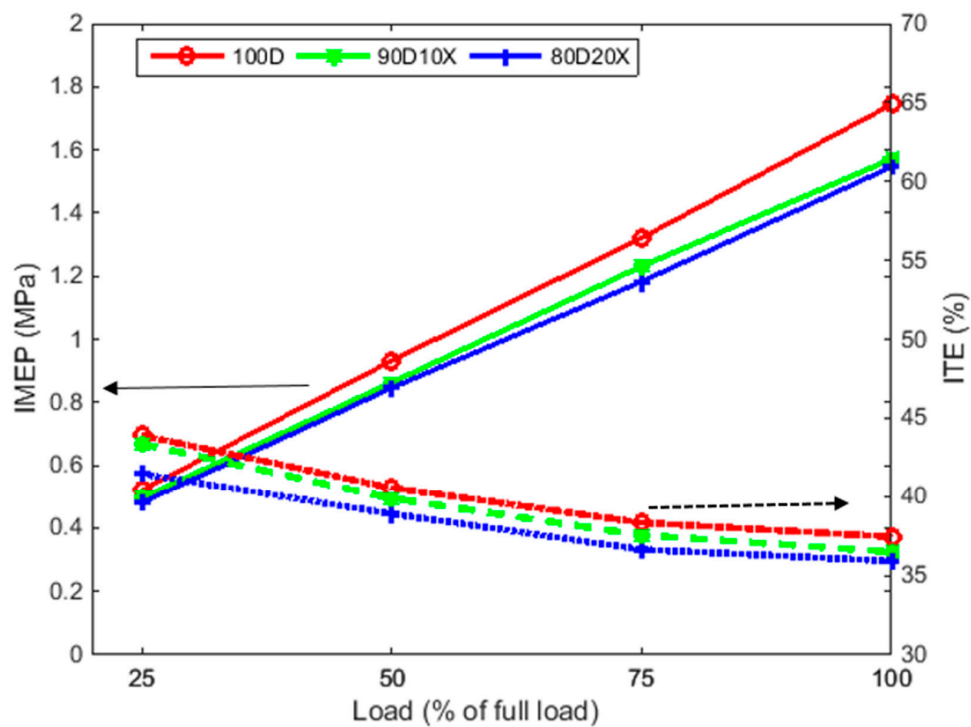
1—measured at QUT, 2—calculated, 3—DOP chemical certificate, 4—Caltex fuel certificate, 5—NREL report (2004) [22].

### 3. Results and Discussion

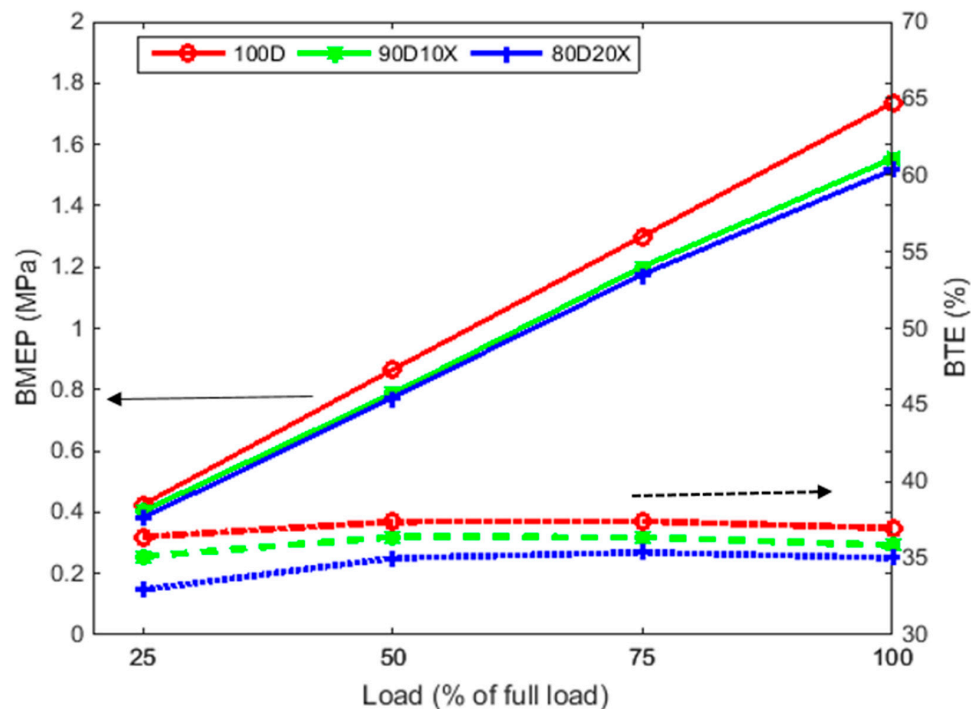
The following chapter has been discussed about the in-cylinder combustion characteristics, overall engine performance and regulated emissions behavior of microalgae extracted DOP-diesel blends.

#### 3.1. Engine Performance and Combustion Parameters

Figure 2 represents the indicated mean effective pressure (IMEP) and indicated thermal efficiency (ITE) with respect to the engine load. As shown in the figure, the variations in IMEP among the tested fuels were more prevalent at higher loads. IMEP for the reference diesel was the highest among the used fuels, and then, reduced gradually with the increase of DOP concentration in the diesel-DOP blends. ITE reduced with decreasing engine loads for all the fuels tested. The highest ITE was also observed for the reference diesel, followed by 90D10DOP and 80D20DOP. These reductions in IMEP and ITE are related to the lower heating value of DOP as well as inferior physical properties related to combustion compared to diesel fuel. Inferior fuel properties reduced in-cylinder combustion efficiency of the fuel, and low energy content in the fuel reduced the in-cylinder energy release per unit fuel mass. Similar results are reported by other studies when they used fuels having inferior physical properties and lower energy content than diesel [23]. For brake mean effective pressure (BMEP) and brake thermal efficiency (BTE; Figure 3) with the same fuels, similar trends were observed to IMEP and ITE for all fuels.



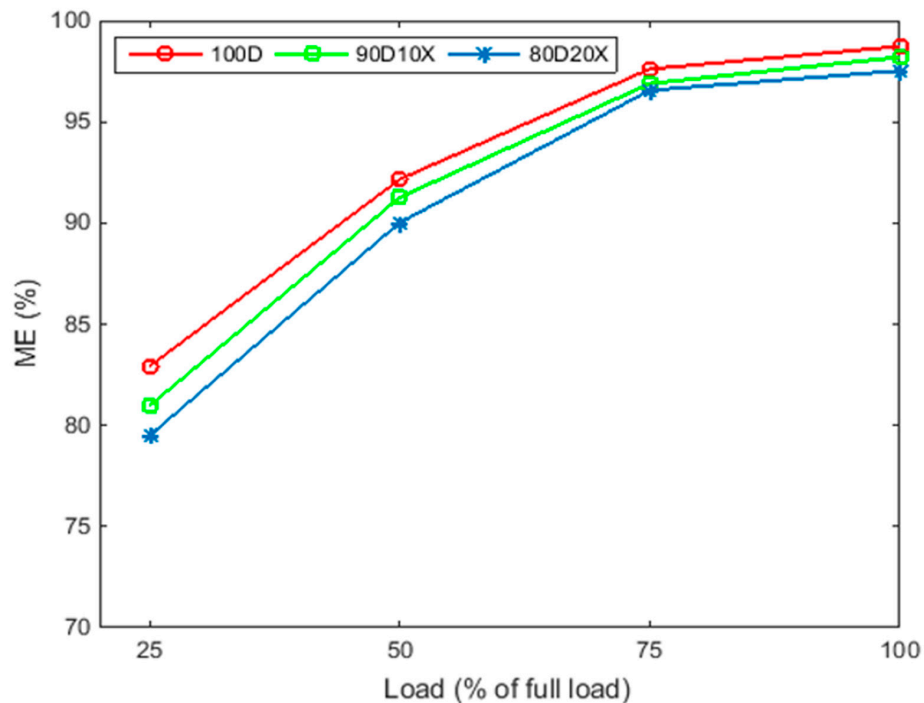
**Figure 2.** Variation of indicated thermal efficiency and indicated mean effective pressure with engine loads for different fuels.



**Figure 3.** Variation of brake thermal efficiency and brake mean effective pressure with engine loads for different fuels.

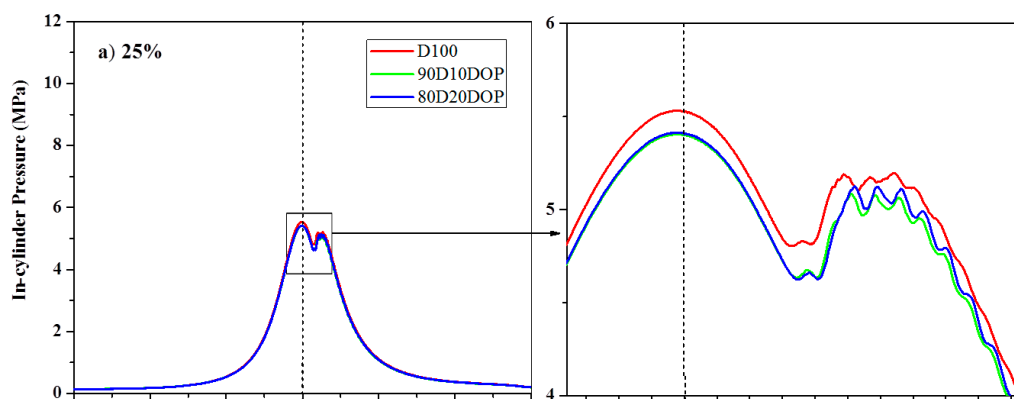
Figure 4 shows the mechanical efficiency (ME) for the reference diesel fuel and two DOP blends. Mechanical efficiency is an engine performance parameter, which can give insight evaluation of friction losses. The ME was calculated from the ratio of brake power and indicated power. ME increases with an increase in engine load for all fuels. Compared to reference diesel, the two DOP blends show lower ME. A maximum reduction in ME was realised with 80D20DOP and then, 90D10DOP, compared to the

reference diesel fuel. This could be due to the higher viscosity of the blended fuel. Higher viscosity will result in higher pumping losses in the fuel delivery system and also, higher frictional losses between the piston rings and cylinder [23].

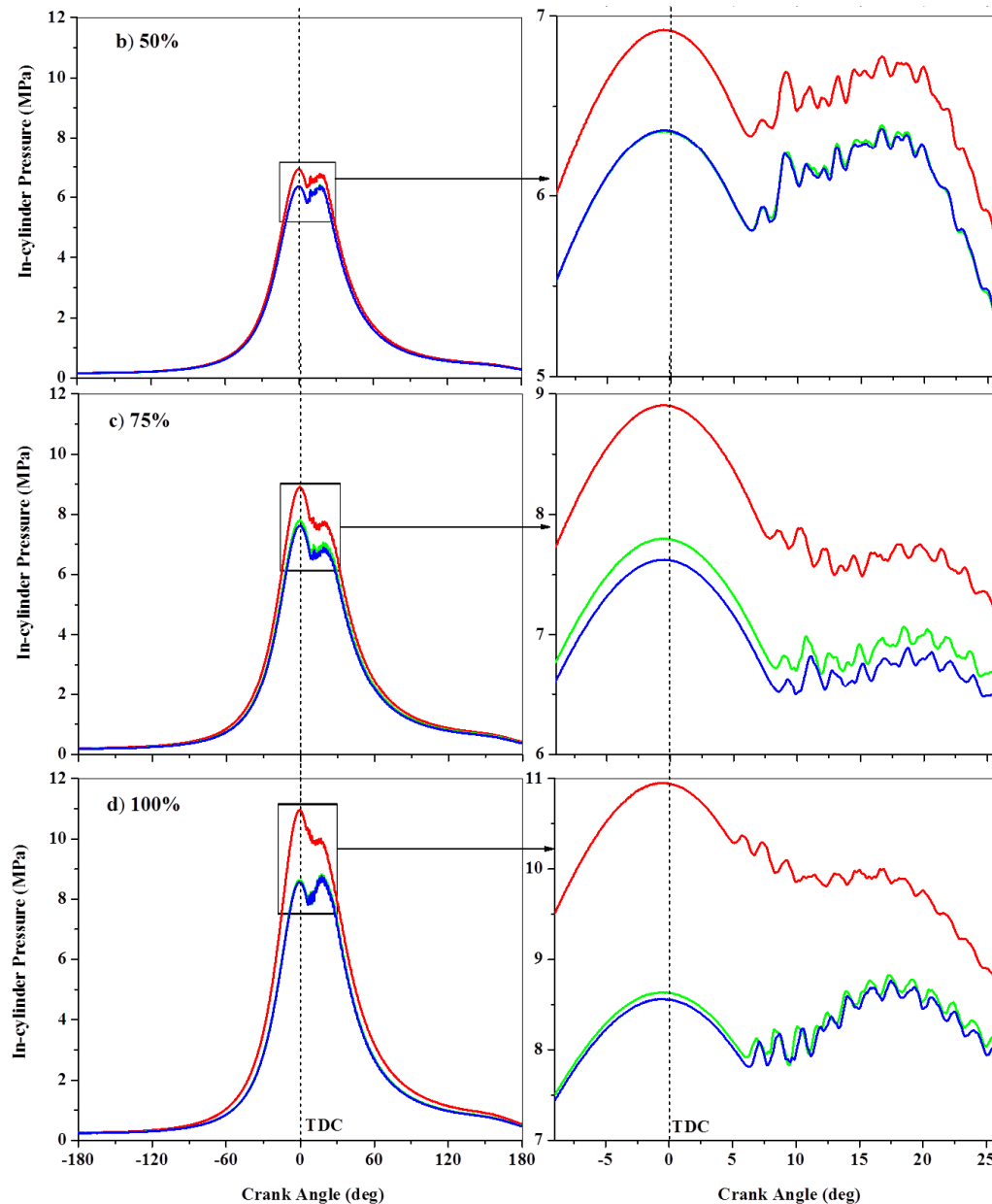


**Figure 4.** Variation of mechanical efficiency and brake thermal efficiency with engine loads for different fuels.

Figure 5 shows in-cylinder pressure vs crank angle diagrams for the tested fuels at 100%, 75%, 50%, and 25% loads, respectively. There was a common trend in all the plots. For each load, the reference fuel (100D) provided the maximum in-cylinder pressure followed by 90D10DOP and 80D20DOP, respectively. The difference in peak in-cylinder pressure among the used fuels was highest at 100% load, which then gradually decreased with engine loads, and at 25% load there was very little difference to notice. The reduction in peak cylinder pressure for DOP blends is due to their lower heating value compared to the reference diesel. It is interesting to note that the blends with higher DOP showed lower peak pressure, which could result from the low energy content of the higher DOP blends. Many studies in the literature have also reported a reduction in peak cylinder pressure with fuels having lower heating values and poorer physical properties [24].



**Figure 5.** Cont.



**Figure 5.** In-cylinder pressure with crank angle (CA) at four loads: (a) 25%; (b) 50%; (c) 75%, and (d) 100%.

### 3.2. Exhaust Emissions

Figures 6–8 represent NO, NO<sub>2</sub>, and NO<sub>x</sub> and emissions from the tested fuels at various engine loads. Overall NO and NO<sub>x</sub> emissions increased with engine load, regardless of fuel type. It is interesting to observe that NO, NO<sub>2</sub>, and NO<sub>x</sub> emissions were the lowest for the reference diesel, and increased slightly with an increase in DOP concentration. It is usual for DOP blended fuel to generate lower in-cylinder temperature than reference diesel because of the relatively higher density, viscosity, surface tension, and lower heating value. High in-cylinder temperature is considered as the primary reason for thermal NO<sub>x</sub> formation in diesel engines [25,26]. Therefore higher NO<sub>x</sub> emissions from DOP blended fuels seem unusual in the case. However, it may be explained if we consider the combustion mechanism. Each DOP molecule has three C–C double bond, two C–O double bond, and four oxygen molecules. Any double bond requires more time and energy to break, and also release more energy once broken. Therefore, DOP molecules could undergo prolonged premixed combustion due to the presence of multiple double bonds as well as lower boiling point and volatility, which are favourable for NO<sub>x</sub>

production. At the same time once those double bonds are broken, they could create an instant local high-temperature spot inside the cylinder, although they do not significantly affect the overall mean spatial in-cylinder temperature. This instantaneous local high-temperature spot could also favour local thermal NO formation, and subsequently, increase overall NO emissions. Increased NO<sub>x</sub> due to the presence of double bonds in the fuel/fuel mix is also commonly reported in the literature [27,28]. Another reason for higher NO<sub>x</sub> emissions with both DOP blends is the presence of fuel oxygen in their molecules. This excess oxygen can contribute to higher NO<sub>x</sub> emissions with the DOP blends [29].

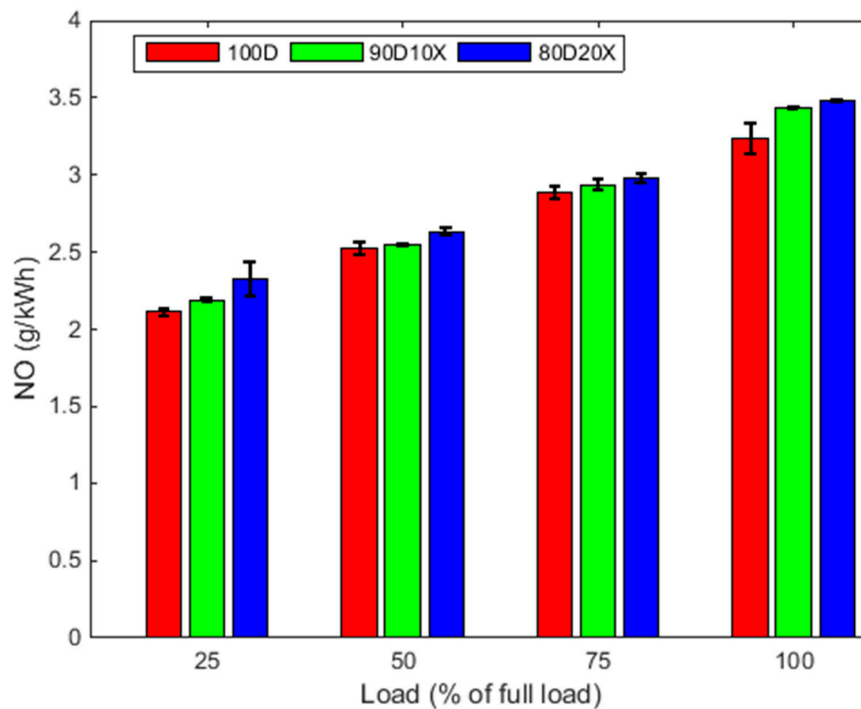


Figure 6. Brake specific NO emission with engine loads for diesel and DOP blends.

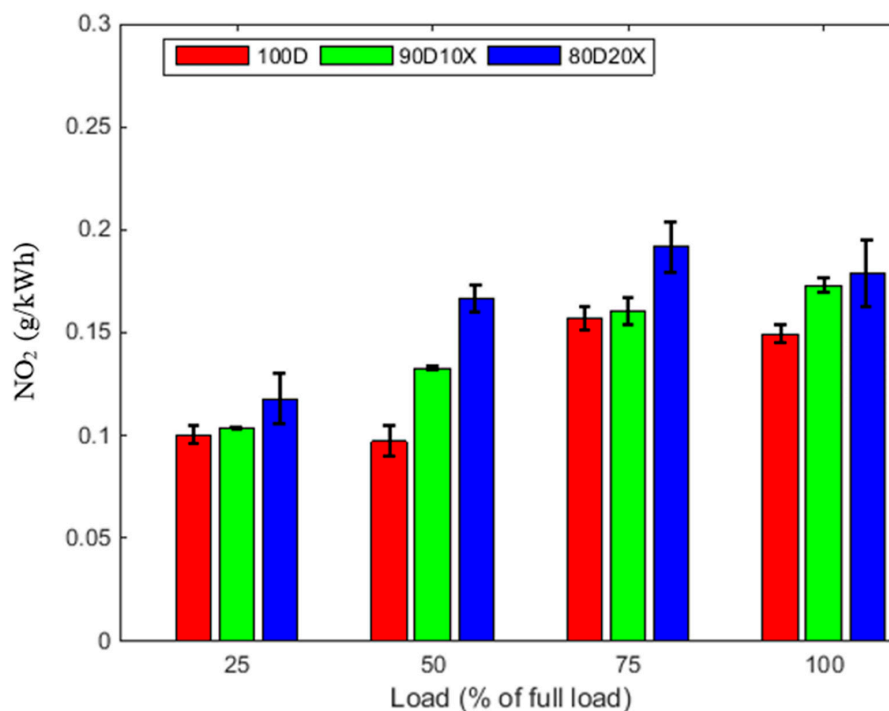
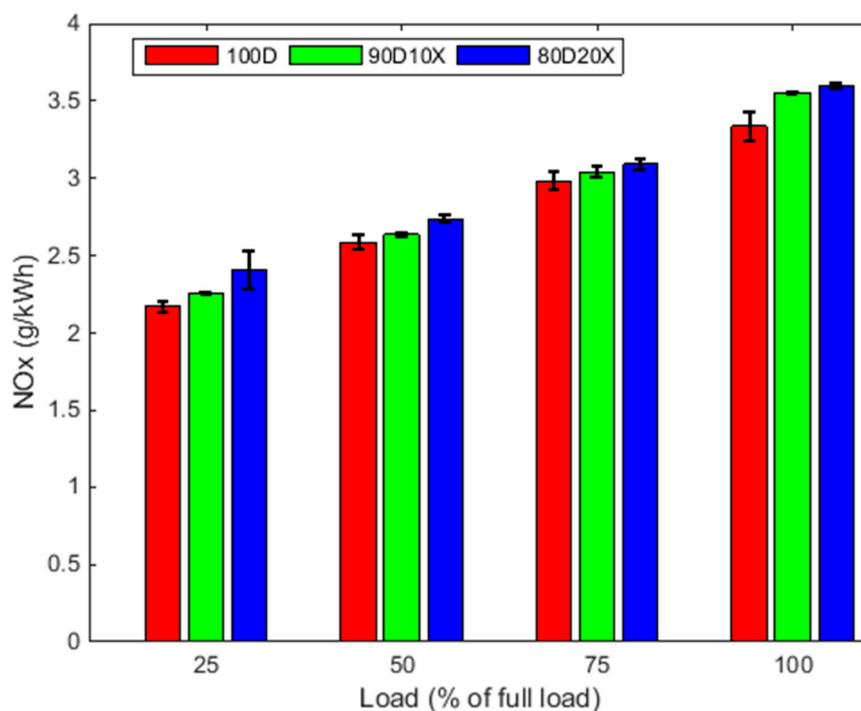


Figure 7. Brake specific NO<sub>2</sub> emission with engine loads for diesel and DOP blends.



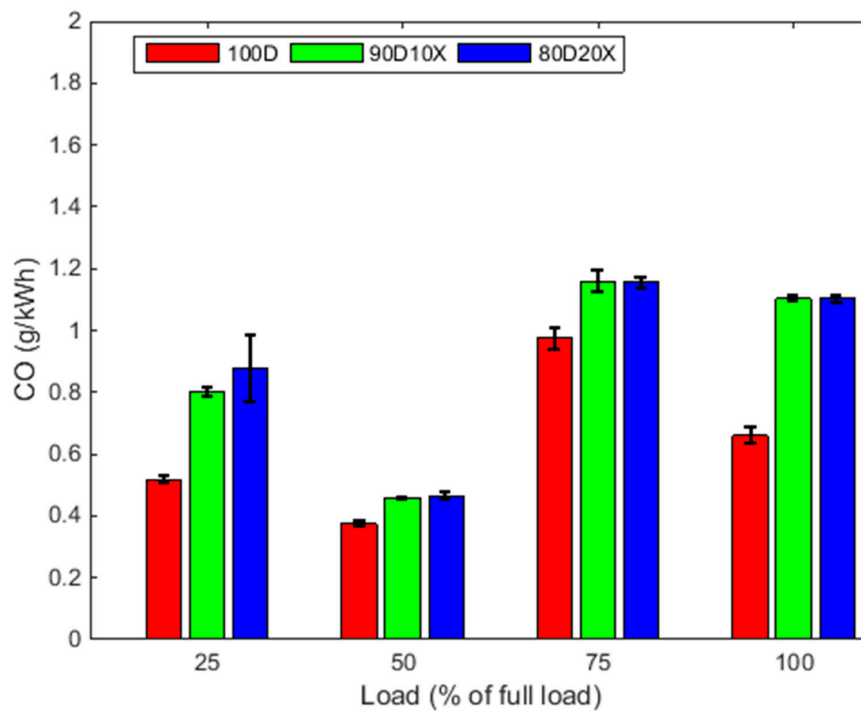


**Figure 8.** Brake specific NO<sub>x</sub> emission with engine loads for diesel and DOP blends.

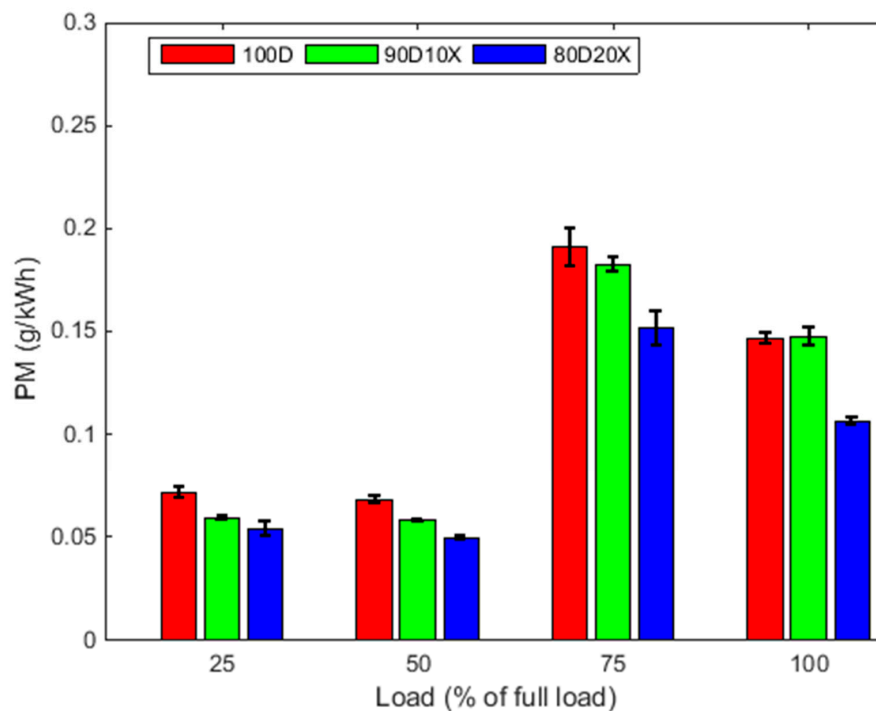
CO is a useful marker for in-cylinder combustion quality. Higher CO emissions indicate inferior combustion. Figure 9 represents the variation of brake specific CO emissions among the used fuels at different engine loads. CO emissions from DOP blended fuels were slightly higher than the reference diesel fuel, regardless of engine loading conditions, although CO emissions from 90D10DOP and 80D20DOP were almost the same, with the exception of 25% load. Low volatile viscous fuels have a poor tendency to mix with air, and cause incomplete/partial combustion resulting in higher CO emissions. The reactivity of DOP would be much lower than diesel due to double C–C bond, which could lead to incomplete combustion. Therefore, the relatively high CO emissions from DOP blended fuels are not unexpected in this research from this point of view. Contrary, the literature suggests a reduction in CO emissions from oxygenated fuels [11]. Since each DOP molecule contains four oxygen atoms, it is reasonable to expect a reduction in CO emissions from DOP blended fuels as well. However, in this case the influence of the physical fuel properties are more dominant than the presence of fuel-borne oxygen.

Figure 10 shows the brake specific PM emissions from the fuels at different engine loads. PM emissions from the reference diesel were the highest among the fuels at all four tested engine loads. With an increase in DOP concentration, PM emissions reduced, except at 100% engine load where PM emissions from reference diesel and 90D10DOP were similar. This PM emission benefit from DOP blended fuel is well expected here since the reduction in PM emissions from oxygenated fuels is common in the literature [30].

On the other hand, fuels having higher density, viscosity, surface tension, and low volatility are favorable for excessive PM emissions [10]. Therefore, one can expect higher PM emissions from DOP blended fuel as well. However, the influence of fuel-borne oxygen suppresses the fuel physical properties effect in this case. Our previous studies also found similar results while using biodiesels from various feed stocks [31]. Fuel-borne oxygen suppresses PM emissions by reducing fuel rich zones inside the combustion chamber and prevents subsequent soot formation as well as enhances oxidation of already formed soot particles.



**Figure 9.** Brake specific CO emission with engine loads for diesel and DOP blends.



**Figure 10.** Brake specific particulate matter (PM) emission with engine loads for diesel and DOP blends.

Particle number (PN) has become a more appropriate metric than PM in recent years for engine exhaust particulates. In recognition, PN based emission standards are already in place alongside with PM. Figure 11 shows the brake specific PN emissions at different engine loads. Interestingly, PN emissions followed the opposite trend than PM trend, except for 25% engine load. PN emissions from DOP blended fuels were higher than the reference diesel at 50%, 75%, and 100% engine loads, which remained almost the same at 25% engine load. Unlike PM, there is hardly any difference in PN emissions between 90D10DOP and 80D20DOP at all engine loads. This discrepancy between PM and

PN emissions might be related to their subsequent measurement techniques. PN was measured from diluted engine exhaust by a Cambustion DMS500, which is capable of efficiently counting particles 5 nm to 1000 nm [32]. On the other hand, PM was measured from the same sampling point, but by using a TSI DustTrak 8530. There is enough evidence in the literature that the DustTrak misses most of the particles under 30 nm [33,34].

A portable raw exhaust gas exhaust analyzer (Testo 360) was used to find the percentage of oxygen in the exhaust gas. Figure 12 shows that the variation percentage of oxygen in the exhaust gas for different loads and fuels. The percentage of oxygen in the exhaust gas has changed with load significantly but the changes at same load for different fuel was not significant.

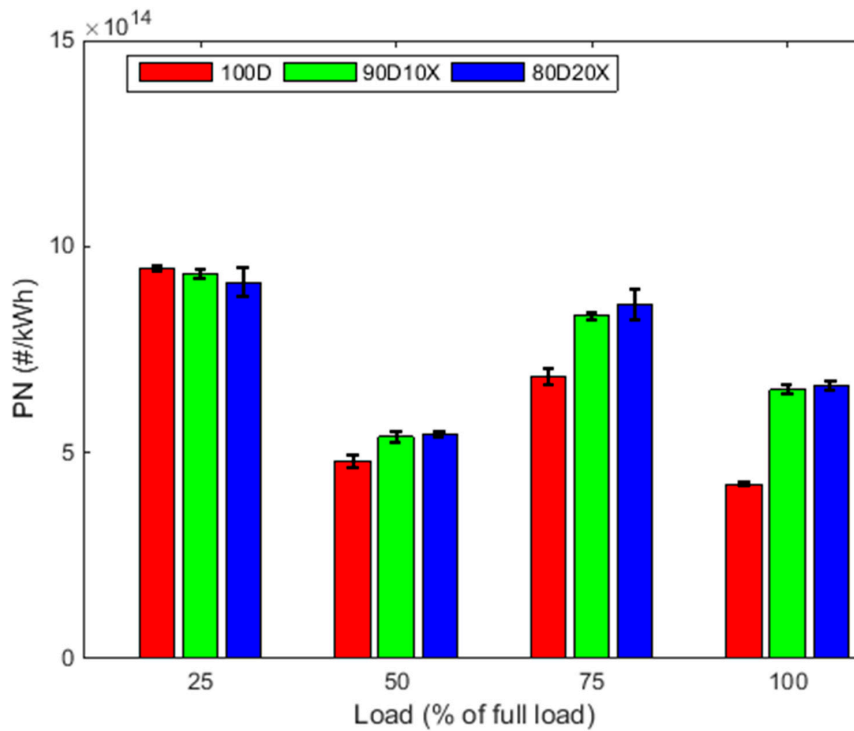


Figure 11. Variation of brake specific particle number (PN) with engine loads for diesel and DOP blends.

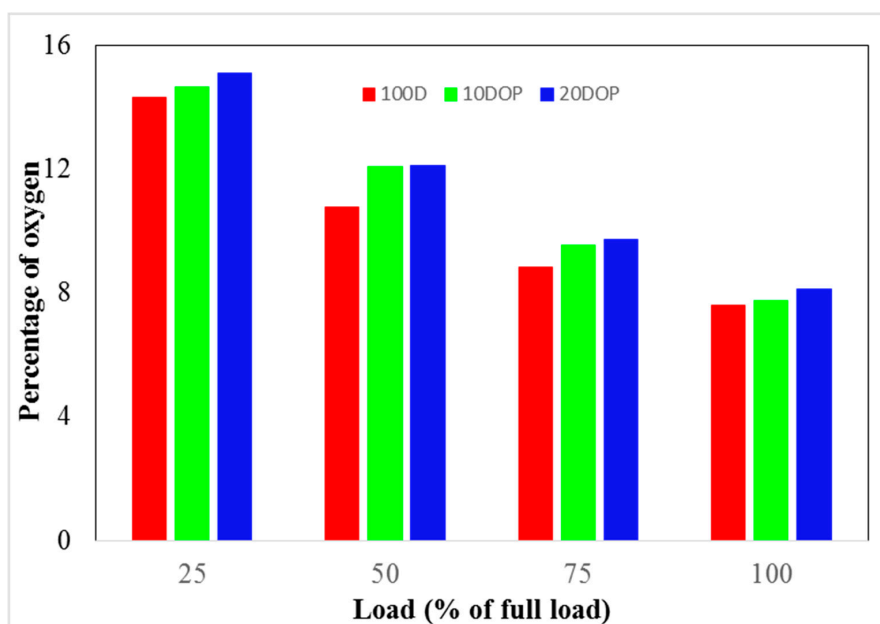


Figure 12. Percentage of oxygen contained in the exhaust gas for diesel and DOP blends.

#### 4. Conclusions

In conclusion, this study investigated the influence of DOP addition to diesel fuel on engine performance and exhaust emissions. Despite a reasonable difference in physical properties, i.e., density, viscosity, surface tension, and boiling point, DOP and diesel fuel were found to be miscible with each other. The physical properties of the diesel-DOP blends were in some cases improved to those of diesel with an increase of DOP concentration. The engine test found a decrease in peak cylinder pressure, indicated mean effective pressure, indicated power, and brake power by 25%, 12.8%, 13%, and 14.4%, respectively. For DOP blended fuels the specific fuel consumption increased by a maximum of 6.33%. Emissions test results revealed a slight increase in NO<sub>x</sub> and CO emissions from DOP blended fuels, whereas the particulate matter (PM) emissions reduced by 37.9%. No conclusive trend was found for particle number (PN) emissions. The slight change in engine performance and emissions behavior of DOP blended fuels are related to the physicochemical properties of DOP.

Nevertheless, this study reveals that up to 20% DOP blended diesel fuel can be used in diesel engine without any significant compromise in engine performance or emissions. Therefore, it can be concluded that hydrothermally liquefied microalgae bio-oil chemical component can be blended and used in diesel engine despite the presence of significant amount (up to 11%) of DOP in it. Although without deteriorating engine performance significantly, both PM were reduced with DOP blends in the present study, however, further study is needed required before taking any initiative to commercialize DOP blended fuels.

**Author Contributions:** Conceptualization, F.M.H. and R.J.B.; Methodology, F.M.H. and S.B.; Software, T.A.B. and K.S.; Formal Analysis, F.M.H.; Investigation, F.M.H., T.C.V., S.M.A.R. and M.M.R.; Data Curation, F.M.H.; Technical Discussions, F.M.H. and S.B.; Writing-Original Draft Preparation, M.M.R. and F.M.H.; Writing-Review & Editing, R.J.B., T.J.R. and M.N.N.; Supervision, R.J.B., Z.R. and T.J.R.

**Funding:** We gratefully acknowledge support from the Australian Research Council through Linkage Grant, LP110200158 and the APC was funded by University of South Australia.

**Acknowledgments:** This research was supported by Queensland University of Technology (QUT). The authors would like to acknowledge Noel Hartnett for his help in conducting the experiments. The authors would like to acknowledge Dr. Md Jahirul Islam for his assistance in this research.

**Conflicts of Interest:** The authors declare no conflicts of interest.

#### Nomenclature

100D	100% Diesel
90D10DOP	90D% Diesel + 10%DOP
80D20DOP	80D% Diesel + 20%DOP
BERF	Biofuel Engine Research Facility
BMEP	Brake Mean Effective Pressure
BP	Brake Power
BTE	Brake Thermal Efficiency
CA	Crank Angle
CAI	California Analytical Instruments
CN	Cetane Number
CO	Carbon Monoxide
DI	Direct Injection
DOP	Diocetyl Phthalate
EGR	Exhaust Gas Recirculation
kJ	Kilojoule
kW	Kilowatt
kWh	Kilo Watt Hour
IMEP	Indicated Mean Effective Pressure
HHV	Higher Heating Value
LHV	Lower Heating Value
MPa	Megapascal

MJ	Megajoule
NDIR	Non-Dispersive Infrared
NO <sub>x</sub>	Nitrogen Oxides
PM	Particulate Matter
PVC	Polyvinyl Chloride
PN	Particle Number

## References

- Huo, S.; Dong, R.; Wang, Z.; Pang, C.; Yuan, Z.; Zhu, S.; Chen, L. Available Resources for Algal Biofuel Development in China. *Energies* **2011**, *4*, 1321–1335. [[CrossRef](#)]
- Hossain, F.; Kosinkova, J.; Brown, R.; Ristovski, Z.; Hankamer, B.; Stephens, E.; Rainey, T. Experimental Investigations of Physical and Chemical Properties for Microalgae HTL Bio-Crude Using a Large Batch Reactor. *Energies* **2017**, *10*, 467. [[CrossRef](#)]
- EIA. Transportation Sector Energy Consumption. 2019; Chapter 8. Available online: [www.eia.gov/outlooks/ieo/pdf/transportation.pdf](http://www.eia.gov/outlooks/ieo/pdf/transportation.pdf) (accessed on 6 May 2019).
- Kalghatgi, G.T. The outlook for fuels for internal combustion engines. *Int. J. Engine Res.* **2014**, *15*, 383–398. [[CrossRef](#)]
- Bodisco, T.A.; Rahman, S.A.; Hossain, F.M.; Brown, R.J. On-road NO<sub>x</sub> emissions of a modern commercial light-duty diesel vehicle using a blend of tyre oil and diesel. *Energy Rep.* **2019**, *5*, 349–356. [[CrossRef](#)]
- Jamrozik, A.; Tutak, W.; Gnatowska, R.; Nowak, Ł. Comparative Analysis of the Combustion Stability of Diesel-Methanol and Diesel-Ethanol in a Dual Fuel Engine. *Energies* **2019**, *12*, 971. [[CrossRef](#)]
- Dalkmann, H.; Brannigan, C. *Transport. and Climate Change: Module 5e*; Deutsche Gesellschaft für Technische Zusammenarbeit (GTZ): Eschborn, Germany, 2007.
- Silverman, D.T.; Samanic, C.M.; Lubin, J.H.; Blair, A.E.; Stewart, P.A.; Vermeulen, R.; Coble, J.B.; Rothman, N.; Schleiff, P.L.; Travis, W.D.; et al. The diesel exhaust in miners study: A nested case-control study of lung cancer and diesel exhaust. *J. Natl. Cancer Inst.* **2012**, *104*, 855–868. [[CrossRef](#)]
- Ge, J.C.; Yoon, S.K.; Choi, N.J. Using Canola Oil Biodiesel as an Alternative Fuel in Diesel Engines: A Review. *Appl. Sci.* **2017**, *7*, 881. [[CrossRef](#)]
- Lapuerta, M.; Armas, O.; Rodríguez-Fernández, J. Effect of biodiesel fuels on diesel engine emissions. *Prog. Energy Combust. Sci.* **2008**, *34*, 198–223. [[CrossRef](#)]
- Xue, J.; Grift, T.E.; Hansen, A.C. Effect of biodiesel on engine performances and emissions. *Renew. Sustain. Energy Rev.* **2011**, *15*, 1098–1116. [[CrossRef](#)]
- Golimowski, W.; Krzaczek, P.; Marcinkowski, D.; Gracz, W.; Wałowski, G. Impact of Biogas and Waste Fats Methyl Esters on NO, NO<sub>2</sub>, CO, and PM Emission by Dual Fuel Diesel Engine. *Sustainability* **2019**, *11*, 1799. [[CrossRef](#)]
- Nabi, M.N.; Zare, A.; Hossain, F.M.; Ristovski, Z.D.; Brown, R.J. Reductions in diesel emissions including PM and PN emissions with diesel-biodiesel blends. *J. Clean. Prod.* **2017**, *166*, 860–868. [[CrossRef](#)]
- Rahman, M.M.; Pourkhesalian, A.M.; Jahirul, M.I.; Stevanovic, S.; Pham, P.X.; Wang, H.; Masri, A.R.; Brown, R.J.; Ristovski, Z.D. Particle emissions from biodiesels with different physical properties and chemical composition. *Fuel* **2014**, *134*, 201–208. [[CrossRef](#)]
- Islam, M.A.; Brown, R.J.; O'Hara, I.; Kent, M.; Heimann, K. Effect of temperature and moisture on high pressure lipid/oil extraction from microalgae. *Energy Convers. Manag.* **2014**, *88*, 307–316. [[CrossRef](#)]
- Barreiro, D.L.; Prins, W.; Ronsse, F.; Brilman, W. Hydrothermal liquefaction (HTL) of microalgae for biofuel production: State of the art review and future prospects. *Biomass Bioenergy* **2013**, *53*, 113–127. [[CrossRef](#)]
- Hossain, F.M.; Nabi, M.N.; Brown, R.J. Investigation of diesel engine performance and exhaust emissions of microalgae fuel components in a turbocharged diesel engine. *Energy Convers. Manag.* **2019**, *186*, 220–228. [[CrossRef](#)]
- Hossain, F.M.; Rainey, T.J.; Ristovski, Z.; Brown, R.J. Performance and exhaust emissions of diesel engines using microalgae FAME and the prospects for microalgae HTL biocrude. *Renew. Sustain. Energy Rev.* **2018**, *82*, 4269–4278. [[CrossRef](#)]
- Hossain, F.M.; Nabi, M.N.; Rainey, T.J.; Bodisco, T.; Rahman, M.M.; Suara, K.; Rahman, S.M.; Van, T.C.; Ristovski, Z.; Brown, R.J. Investigation of microalgae HTL fuel effects on diesel engine performance and exhaust emissions using surrogate fuels. *Energy Convers. Manag.* **2017**, *152*, 186–200. [[CrossRef](#)]

20. Jamriska, M.; Morawska, L.; Thomas, S.; He, C. Diesel bus emissions measured in a tunnel study. *Environ. Sci. Technol.* **2004**, *38*, 6701–6709. [CrossRef]
21. Rahman, M.M.; Stevanovic, S.; Brown, R.J.; Ristovski, Z. Influence of Different Alternative Fuels on Particle Emission from a Turbocharged Common-Rail Diesel Engine. *Procedia Eng.* **2013**, *56*, 381–386. [CrossRef]
22. NREL. Biodiesel Handling and Use Guide. 2009. Fourth Edition. Available online: <http://www.biodiesel.org/docs/using-hotline/nrel-handling-and-use.pdf?sfvrsn=4> (accessed on 4 May 2019).
23. Saad, I.; Bari, S. Optimize vane length to improve in-cylinder air characteristic of CI engine using higher viscous fuel. *Appl. Mech. Mater.* **2013**, *393*, 293–298. [CrossRef]
24. Zaharin, M.S.; Abdullah, N.R.; Najafi, G.; Sharudin, H.; Yusaf, T. Effects of physicochemical properties of biodiesel fuel blends with alcohol on diesel engine performance and exhaust emissions: A review. *Renew. Sustain. Energy Rev.* **2017**, *79*, 475–493. [CrossRef]
25. Bari, S.; Saad, I. Performance and emissions of a compression ignition (CI) engine run with biodiesel using guide vanes at varied vane angles. *Fuel* **2015**, *143*, 217–228. [CrossRef]
26. Chybowski, L.; Laskowski, R.; Gawdzińska, K. An overview of systems supplying water into the combustion chamber of diesel engines to decrease the amount of nitrogen oxides in exhaust gas. *J. Mar. Sci. Technol.* **2015**, *20*, 393–405. [CrossRef]
27. Hoekman, S.K.; Robbins, C. Review of the effects of biodiesel on NO<sub>x</sub> emissions. *Fuel Process. Technol.* **2012**, *96*, 237–249. [CrossRef]
28. Allan, R.; Williams, J.; Rogerson, J. Effect of the Molecular Structure of Individual Fatty Acid Alcohol Esters (Biodiesel) on the Formation of Nox and Particulate Matter in the Diesel Combustion Process. *SAE Int. J. Fuels Lubr.* **2008**, *1*, 849–872.
29. Nabi, M.N.; Zare, A.; Hossain, F.M.; Rahman, M.M.; Bodisco, T.A.; Ristovski, Z.D.; Brown, R.J. Influence of fuel-borne oxygen on European Stationary Cycle: Diesel engine performance and emissions with a special emphasis on particulate and NO emissions. *Energy Convers. Manag.* **2016**, *127*, 187–198. [CrossRef]
30. Wang, Y.; Liu, H.; Lee, C.-F.F. Particulate matter emission characteristics of diesel engines with biodiesel or biodiesel blending: A review. *Renew. Sustain. Energy Rev.* **2016**, *64*, 569–581. [CrossRef]
31. Rahman, M.M.; Stevanovic, S.; Islam, M.A.; Heimann, K.; Nabi, M.N.; Thomas, G.; Feng, B.; Brown, R.J.; Ristovski, Z.D. Particle emissions from microalgae biodiesel combustion and their relative oxidative potential. *Environ. Sci. Process. Impacts* **2015**, *17*, 1601–1610. [CrossRef]
32. Symonds, J.P.; Reavell, K.S.; Olfert, J.S.; Campbell, B.W.; Swift, S.J. Diesel soot mass calculation in real-time with a differential mobility spectrometer. *J. Aerosol Sci.* **2007**, *38*, 52–68. [CrossRef]
33. Maricq, M.M. Monitoring Motor Vehicle PM Emissions: An Evaluation of Three Portable Low-Cost Aerosol Instruments. *Aerosol Sci. Technol.* **2013**, *47*, 564–573. [CrossRef]
34. Quiros, D.C.; Yoon, S.; Dwyer, H.A.; Collins, J.F.; Zhu, Y.; Huai, T. Measuring particulate matter emissions during parked active diesel particulate filter regeneration of heavy-duty diesel trucks. *J. Aerosol Sci.* **2014**, *73*, 48–62. [CrossRef]



© 2019 by the authors. Licensee MDPI, Basel, Switzerland. This article is an open access article distributed under the terms and conditions of the Creative Commons Attribution (CC BY) license (<http://creativecommons.org/licenses/by/4.0/>).