

Review

Recent Advances on the Valorization of Glycerol into Alcohols

Louise R. Smith , Mark Douthwaite, Karl Mugford, Nicholas F. Dummer , David J. Willock, Graham J. Hutchings  and Stuart H. Taylor * 

Max Planck-Cardiff Centre on the Fundamentals of Heterogeneous Catalysis FUNCAT, Cardiff Catalysis Institute, School of Chemistry, Cardiff University, Main Building, Park Place, Cardiff CF10 3AT, UK

* Correspondence: taylorsh@cardiff.ac.uk

Abstract: Glycerol, a highly functionalised polyol, can be used as a platform molecule to produce a variety of high-value chemicals. As glycerol production is projected to increase over the coming years, it's critically important that technology and infrastructure are developed to make use of the inevitable surplus. The catalytic production of 'green' mono alcohols from glycerol, in the absence of H₂, is an emerging area of research that, in recent years, has generated significant industrial interest. Herein, we provide an update on recent advances in this field and discuss challenges which need to be overcome if this approach is to be considered viable industrially. The economic significance of using crude glycerol as a feedstock for glycerol valorisation strategies is also addressed and suggestions for improving the impact of research conducted in this field are proposed.

Keywords: glycerol; methanol; catalysis; biomass; liquid fuels; sustainability



Citation: Smith, L.R.; Douthwaite, M.; Mugford, K.; Dummer, N.F.; Willock, D.J.; Hutchings, G.J.; Taylor, S.H. Recent Advances on the Valorization of Glycerol into Alcohols. *Energies* **2022**, *15*, 6250. <https://doi.org/10.3390/en15176250>

Academic Editor: Jude Onwudili

Received: 18 July 2022

Accepted: 25 August 2022

Published: 27 August 2022

Publisher's Note: MDPI stays neutral with regard to jurisdictional claims in published maps and institutional affiliations.



Copyright: © 2022 by the authors. Licensee MDPI, Basel, Switzerland. This article is an open access article distributed under the terms and conditions of the Creative Commons Attribution (CC BY) license (<https://creativecommons.org/licenses/by/4.0/>).

1. Introduction

Glycerol, a C₃ triol, can be valorised catalytically into a number of high value chemical derivatives [1–5]. While several processes for its synthesis have been established [6], it is predominantly produced commercially as a by-product of triglyceride transesterification. This process is critically important for the manufacture of biodiesel, where fatty acid methyl esters (FAME) are produced through the transesterification of triglycerides. In this process, approximately 1 ton of glycerol is generated (as a by-product) for every 10 tonnes of biodiesel that is produced [7].

Biofuels are expected to play a significant role in reducing global dependence on fossil derived fuels. A recent international energy agency (IEA) report projected that the global demand for biofuels is to increase by 28% from 2021 to 2026 [8], but more rapid expansion of these commodities are required in order to meet the 'IEA Net Zero by 2050 Scenario'. Whilst bioethanol is expected to meet a large proportion of the projected quota, biodiesel production must also be accelerated to meet these demands. Statista recently projected that the global biodiesel industry will be worth ca. 49.2 billion U.S. dollars by 2024 [9]. In a separate IEA report, it was predicted that, annually, ca. 63 billion L of biodiesel will be produced globally between 2023 and 2025 [10].

Over the last thirty years, increased global biodiesel production has driven down the price of crude glycerol (CG); the glycerol by-product isolated from commercial biodiesel plants. In 2019, CG was valued at a mere ca. USD 170/ton [11]. Given the projected increase in biodiesel production, it is inevitable that this price will continue to fall, as availability continues to outstrip demand. For these reasons, glycerol has the potential to be a highly lucrative chemical platform should appropriate technology and infrastructure be developed for its valorisation. Buoyed by this potential, researchers have endeavored to develop economically viable processes to valorise glycerol. This is evidenced by the increased number of publications on this topic over the last two and a half decades (Figure 1). During this time, researchers have demonstrated that glycerol can be valorised into a variety of high value derivatives, by adopting different reaction conditions, reagents and catalysts.

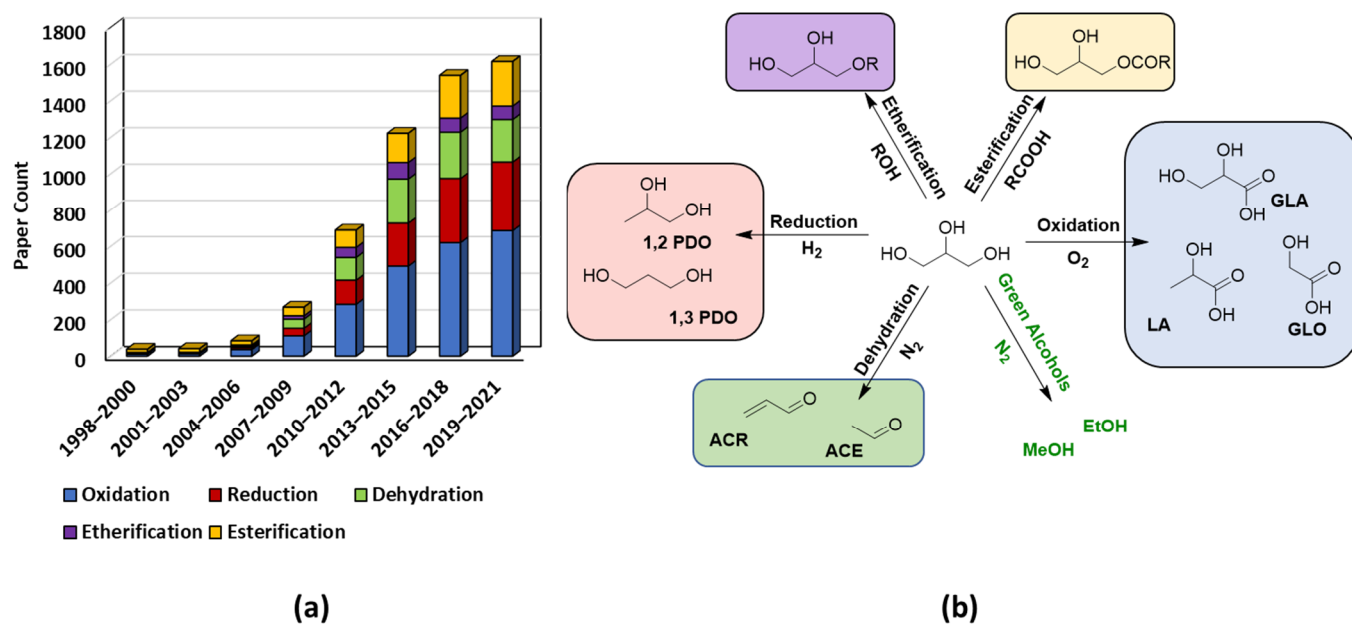

Figure 1. Evolution of research into catalysed glycerol valorization. (a) The number of papers published on catalytic glycerol valorisation since 1998; data sets collated every three years. Paper count acquired through web of knowledge search, where ‘glycerol’ and ‘catalyst’ were entered as topic search items, along with ‘oxidation’ (blue), ‘reduction’ (red), ‘dehydration’ (green), ‘etherification’ (purple) and ‘esterification’ (yellow). (b) schematic representation of each of the valorisation processes, typical reagents and key products. KEY: LA (lactic acid); GLA (glyceric acid); GLO (glycolic acid); PDO (propanediol); ACR (acrolein); ACE (acetonitrile).

The selective oxidation or reduction of glycerol have been particularly competitive research fields [12–14]. Under appropriate conditions, glycerol can be selectively oxidised or reduced into fine chemicals, such as dihydroxyacetone [15,16], lactic acid [17,18], 1,2-propanediol [19–21], or 1,3-propanediol [22,23]. Whilst these processes are of economic interest, they typically rely on the use of reagents like O_2 or H_2 , specialised catalysts and/or additives (such as bases) to promote productivity. While academically interesting, these requirements are often detrimental to commercial viability. This is particularly pertinent given that the catalysts involved often possess well defined active sites that are likely to be extremely sensitive to the impurities present in CG. Processes that do not require such additives are likely to be more appealing, such as glycerol dehydration. As an example, glycerol can be dehydrated over a variety of catalysts to acrolein [24,25]. Acrolein is a primary precursor for the synthesis of acrylic acid, which can be used in a large number of applications [26]. Through reaction with other reagents, glycerol can also undergo etherification or esterification to produce a variety of fuel additives and fine chemicals [27,28]. Glycerol polymers can also be produced through a variety of synthetic routes, resulting in polymers with a wide range of properties [29].

The production of hydrogen through glycerol reforming has also received significant attention, both in the aqueous phase [30] and via steam reforming [31]. Glycerol hydrogenolysis without the addition of external hydrogen, instead using H_2 generated in situ via glycerol reforming has also been demonstrated [32,33]. Hydrogen can also be produced alongside a variety of value added chemicals through catalytic glycerol electrolysis, whereby glycerol oxidation products are produced at the anode, with H_2 production occurring in parallel at the cathode [34]. In addition to these chemocatalytic routes, the biotransformation of glycerol to higher value products has also been widely explored [35], with products such as dihydroxyacetone [36], 1,3-propanediol [37], and succinic acid [38] reported via microbial bioconversions.

In 2015, work from our group determined that significant quantities of methanol could be produced from glycerol over simple metal oxide catalysts [39]. An important aspect of this approach was that it could be operated continuously under ambient pressure using aqueous glycerol feeds and does not require any supplementary reductants or oxidants. Whilst cracking a highly functionalised chemical into a simple mono alcohol may seem somewhat counterintuitive, this approach bares several benefits. Methanol is itself used as a fuel, and can be blended with gasoline to increase the overall octane rating of the fuel [40,41]. Another potential benefit of producing such chemicals from waste glycerol from the bio-diesel industry, is that they can be re-integrated (as reagent) into the transesterification process. This circular economy could be highly advantageous if such technology could be integrated into biodiesel plants. The savings made on purification and transportation costs have the potential to make this process economically competitive compared to sourcing fossil derived methanol, and could even be profitable if legislation to promote such sustainable working practices is introduced.

Numerous comprehensive glycerol reviews have been published, with some covering general advancements in glycerol valorisation [3,4,42–46] and others highlighting the advancements made within a specific process [16,47–50] or the production of a desired chemical [51–54]. Throughout this review, we aim to highlight the progress and advancements surrounding the conversion of glycerol to alcohols without the addition of an external H₂ source. We will focus on the novel process mentioned above, which involves the conversion of vaporized aqueous glycerol feeds to methanol over metal oxide catalysts, highlighting recent developments and progress in this area. Alternative processes for the conversion of glycerol to alcohols are also briefly discussed, namely the Supermethanol concept and glycerol hydrogenolysis. Following this, we will provide an update into the utilisation of crude glycerol and the overall outlook for the conversion of glycerol to alcohols and efficient crude glycerol usage.

2. Glycerol Valorization into Alcohols

2.1. Glycerol to Methanol

As mentioned above, in 2015 we demonstrated the conversion of a vaporised aqueous glycerol feed to methanol, and a number of other products, over a simple redox or basic catalyst, such as CeO₂ or MgO [39]. This process is operated without the addition of an external reductant, and when reactions were performed with D₂O in place of H₂O, a significant kinetic isotope effect was observed, suggesting that water provided the required hydrogen for the production of methanol. Experiments performed with ¹⁸OH₂ showed an absence of any ¹⁸O-MeOH, confirming that glycerol, and not water, was the source of oxygen to form methanol.

A moderate glycerol conversion of 26% was obtained over a MgO catalyst with a 10 wt.% glycerol feedstock at a reaction temperature of 300 °C, with a corresponding methanol selectivity of 41%. The catalytic activity was determined to be stable for a period of 35 h, and glycerol conversion and methanol selectivity could be maintained with a glycerol concentration up to 30 wt.%, achieved by accordingly increasing catalyst mass. Further experiments attempting to increase glycerol conversion by increasing the mass of catalyst and/or reaction temperature were unsuccessful over MgO catalysts. Similar catalytic performance was achieved over a CeO₂ catalyst, although full glycerol conversion was achieved at 400 °C, with a maximum methanol selectivity of 60% at 380 °C (10 wt.% glycerol)

Alongside methanol, a variety of additional products were also observed, including hydroxyacetone, acrolein, acetaldehyde, ethanol, ethylene glycol, allyl alcohol, acetone, propionaldehyde, 2,3-butanedione and CO₂. A number of these products were used as reactants for the process to gain deeper insights in to the complex chemistry occurring during the conversion of glycerol to methanol. Mono alcohols and formyl compounds, such as methanol, ethanol, 1-propanol, 2-propanol, acetone and acrolein were all found to be unreactive, leading to their classification as terminal products. On the contrary, significant

quantities of methanol were isolated in reactions where diols like ethylene glycol and 1,3-propanediol were used as feedstock, suggesting that more than one hydroxyl group is required in the starting material to produce methanol.

The major reaction pathway identified as a route to methanol involved the dehydration of glycerol to hydroxyacetone, occurring at the terminal alcohol position. Hydroxyacetone then undergoes fragmentation by a radical process, related to a type 1 Norrish reaction to yield hydroxymethyl and acetyl radicals, which undergo further reduction to methanol and acetaldehyde, respectively. The presence of 2,3-butanedione, a C₄ product, in the product mixture supports this mechanism as 2,3-butanedione is a coupling product of two acetyl radicals and unlikely to form through another route.

A second reaction pathway to methanol was also proposed, whereby glycerol itself radically fragments to yield hydroxymethyl and ethylene glycol radicals, with the former reduced to methanol and the latter losing a hydrogen radical to form hydroxyacetaldehyde. Similar to hydroxyacetone fragmentation, hydroxyacetaldehyde undergoes a radical fragmentation to yield hydroxymethyl and formaldehyde radicals, both of which can be reduced to methanol; only traces of formaldehyde were detected (in the parts per million range), suggesting this is effectively reduced to methanol under the reaction conditions. Whilst hydroxyacetaldehyde was not detected in the product mixture, as a likely consequence of its high reactivity, ethylene glycol was observed, likely from the reduction of hydroxyacetaldehyde. An additional reaction pathway was also observed over MgO and CeO₂ which did not result in the formation of methanol. This is the double dehydration of glycerol to acrolein, which is initiated by dehydration at the secondary position, forming 3-hydroxypropanal, which is further dehydrated to yield acrolein. Typically acrolein selectivity was <10%, likely due to the absence of strong Brønsted acid sites, which are necessary for high acrolein yields. The proposed reaction scheme is illustrated in Scheme 1.

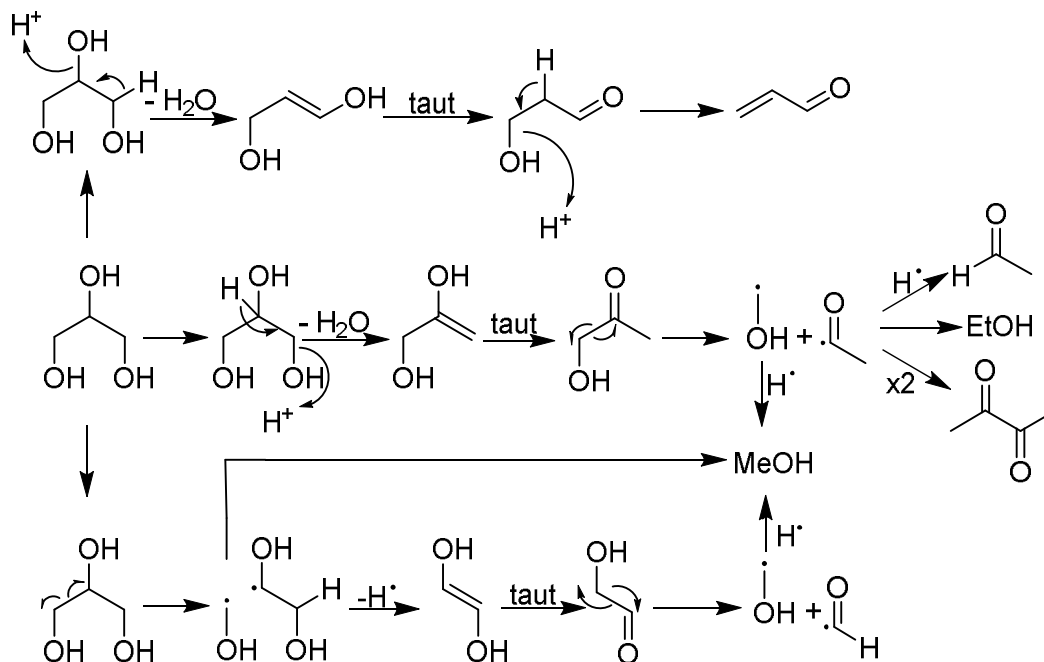

Scheme 1. Proposed reaction scheme for the formation of methanol from glycerol. Scheme reproduced from ref [39] with permission from Springer Nature.

The efficient utilisation of crude glycerol is of great importance, when the economic viability of the process is considered. For this reason, crude glycerol was obtained from a biodiesel producer, Biodiesel Amsterdam BV, for use as a feedstock in the process to explore the feasibility of converting crude glycerol to methanol. This was composed of two phases, namely an aqueous glycerol phase and an organic phase comprising unreacted

triglycerides and other organic matter. The aqueous and organic layers were separated before the aqueous phase was gravity filtered over activated carbon, which removed any coloured impurities and left a colourless solution. The treated crude glycerol was then diluted to the appropriate concentration and reacted over a CeO₂ catalyst.

As shown in Table 1, the glycerol conversion, methanol selectivity and methanol space-time-yield (STY) were somewhat lower with the crude feedstock, which became more pronounced as the glycerol feed concentration increased. Despite the slight drop in performance, these results indicate that the crude glycerol, obtained directly from a biodiesel producer, can be converted to methanol without the need for extensive purification steps prior to reaction.

Table 1. Comparison of pure and crude glycerol over a CeO₂ catalyst. Data reproduced from ref. [39] with permission from Springer Nature. Reaction conditions: 1.0 g catalyst, 1 mL h⁻¹ glycerol/water flow, 100 mL min⁻¹ Ar, 340 °C reaction temperature, 3 h reaction time.

Feedstock Concentration (%)	15 wt.%		30 wt.%		50 wt.%	
Glycerol Source	Pure	Crude	Pure	Crude	Pure	Crude
Glycerol conversion (%)	76	70	55	50	40	30
MeOH selectivity (%)	56	55	41	38	34	29
STY (g _{MeOH} kg _{cat} ⁻¹ h ⁻¹)	18	16	21	19	25	18
Experimental error is ±5%						

Interestingly, for both the pure and crude feedstocks, increasing the feedstock concentration did not result in a proportional increase in methanol STY, with only minor increases in STY upon increasing glycerol concentration from 15 to 50 wt.%. Similarly, comparison of 0.5 and 10 wt.% feedstocks over MgO showed significantly higher methanol selectivity, with the lower selectivity observed with the more concentrated feedstock, attributed to the higher selectivity towards intermediates and by-products, e.g., hydroxyacetone, acetaldehyde, acrolein and ethylene glycol. Consequently, no noticeable increase in methanol STY was observed upon increasing the glycerol concentration from 0.5 wt.% to 10 wt.%, despite the possibility for a six-fold increase when accounting for the additional mass of catalyst. These results were indicative of an increase of undesirable side reactions, with a more concentrated feedstock leading to lower methanol selectivity.

The above results highlight the increasing complexity of the reaction scheme with increasingly concentrated glycerol feedstocks, hence it was considered crucial to gain a greater understanding of the numerous side reactions, which can occur and reduce selectivity to methanol [55]. Due to the heterogeneity of crude glycerol, the following reactions were performed with high purity glycerol to better understand the complex reaction scheme without the additional complications that arise with the use of crude glycerol. The conversion of a 50 wt.% aqueous glycerol feedstock in the absence of any catalyst was initially explored, in an empty reaction tube, and over a bed of SiC, commonly used as a catalyst diluent, between temperatures of 320–480 °C. A maximum conversion of 10% was obtained in an empty reactor tube at a temperature of 480 °C, which increased to 18% in the presence of SiC. The major products were allyl alcohol and hydroxyacetone which contributed to alcohol and ketone yields of ca. 4%. Whilst these results may suggest that SiC is not an inert diluent, we propose that the increased conversion observed in the presence of SiC can be attributed to the significant reduction of volume in the reactor, leading to higher contact between glycerol and a hot surface resulting in increased conversion. The increased glycerol conversion observed in the absence of a catalyst with increasing reaction temperatures highlight the importance of operating the process at more moderate temperatures (<400 °C) to try and minimise competing side reactions.

The effect of reaction temperature on the conversion of a 50 wt.% glycerol solution over MgO was also explored. At a temperature of 360 °C, hydroxyacetone, 1,2-propanediol and ethylene glycol were the main products identified, although the selectivity to these

products decreased dramatically as the reaction temperature was increased, highlighting their role as intermediates in the process. Methanol selectivity was found to reach a maximum of 27.9 carbon mol.% at 400 °C, corresponding to a STY of 205 g h⁻¹ kg⁻¹_{cat}. Increasing the reaction temperature further to 440 °C resulted in a slight decrease in methanol selectivity to 25.6%, corresponding to a STY of 204 g⁻¹ kg⁻¹. The decreased methanol selectivity observed at 440 °C was attributed to an increase in acetaldehyde and CO_x, which was similar to reactions without a catalyst. Similarly, increasing the contact time by reducing the gas-hourly-space-velocity (GHSV) resulted in increased acetaldehyde selectivity. In addition to the major products discussed here, a variety of other products were also observed, although often in trace amounts; the full product distribution is shown in Scheme 2.

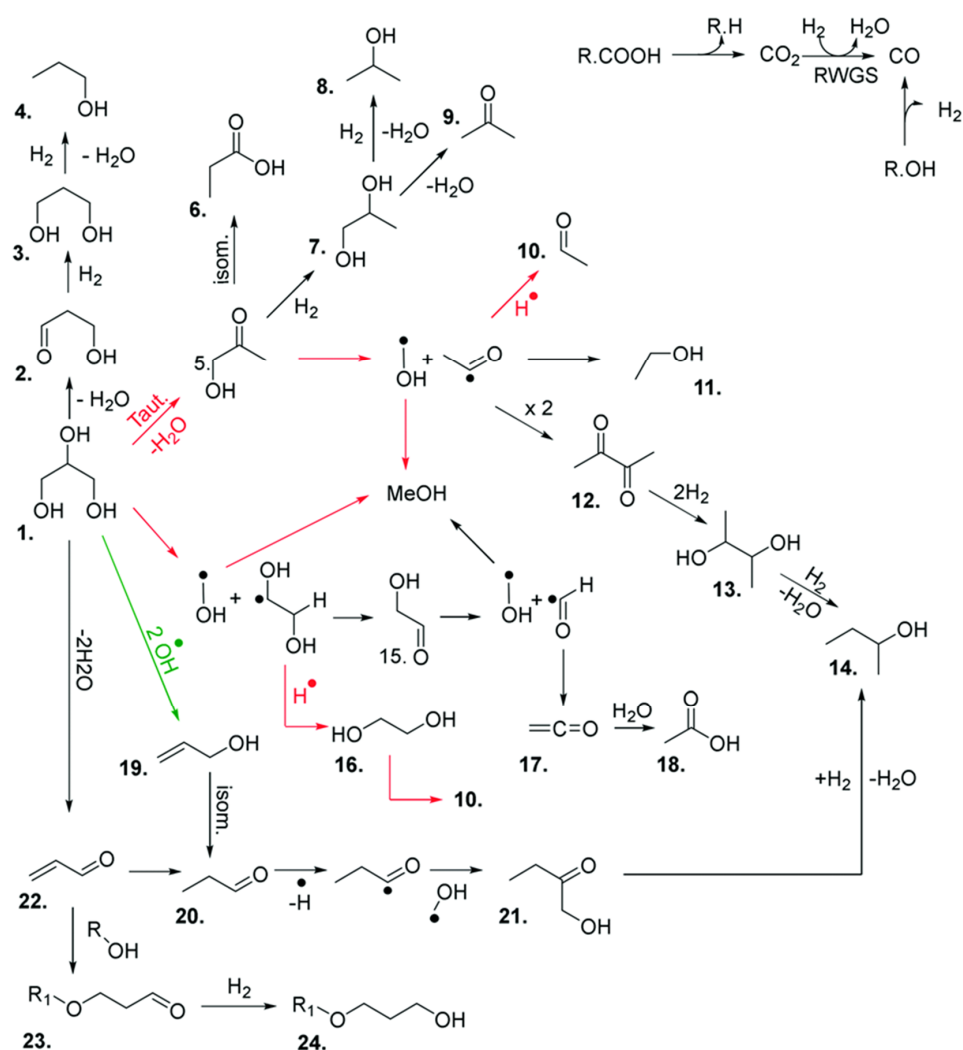

Scheme 2. “Proposed reaction network for the gas phase conversion of glycerol over MgO. Red arrows indicate the dominant pathways over MgO; the green arrow represents the dominant pathway observed in the absence of a catalyst. 1. Glycerol; 2. 3-hydroxypropenal; 3. 1,3-propanediol; 4. 1-propanol; 5. hydroxyacetone; 6. propanoic acid; 7. 1,2-propanediol; 8. 2-propanol; 9. acetone; 10. acetaldehyde; 11. ethanol; 12. 2,3-butanedione; 13. 2,3-butandiol; 14. 2-butanol; 15. glycolaldehyde; 16. ethylene glycol; 17. ethenone; 18. acetic acid; 19. allyl alcohol; 20. 1-propanal; 21. 1-hydroxyl-2-butanone; 22. acrolein; 23. 3-alkoxypropanal; 24. 3-alkoxy propanol.” Figure and caption reproduced from ref. [55] with permission from the Royal Society of Chemistry.

The effect of glycerol feedstock concentration was also explored at a reaction temperature of 400 °C. A maximum methanol selectivity of 34.9% was obtained over a 10 wt.%

solution, with slight decreases observed upon increasing the concentration. Given that the catalyst mass was proportionately reduced to account for the reduction of glycerol in the feed, the methanol STY increased dramatically to $255 \text{ g h}^{-1} \text{ kg}^{-1}$. Lower carbon balances were also detected for the more concentrated feedstocks, suggesting additional products were formed that were not quantified through the analysis procedure. Following these experiments, the stability of the MgO catalyst over an extended time period was explored with a 50 wt.% feedstock, since it was envisaged that more rapid deactivation would occur with a more concentrated feed. A decrease in glycerol conversion was observed over the initial 4 h, but this stabilised at ca. 87% where it remained stable over the rest of the 48-h testing period. Similarly, the carbon balance was stable after the initial 4 h on stream, although this was found to be low, at ca. 65%. Methanol selectivity and STY also followed a similar trend to that of glycerol conversion, with stable activity maintained after the initial 4-h period.

The stable catalytic activity over a period of 48 h showed no significant catalyst deactivation, despite the low carbon balances (typically $< 80\%$). Thermal gravimetric analysis (TGA) showed that there were moderate levels of carbon deposition on the catalyst after reaction, but this did not account for all the missing carbon. Similarly, TGA of post-reaction catalysts after different periods on time-on-stream showed a non-linear relationship with reaction time and coke deposition, indicating that coke formation predominantly occurs early in the reaction. Due to the basic nature of MgO, it was hypothesised that the low observed carbon balances could be due to the occurrence of condensation reactions between glycerol molecules and/or intermediates. Consequently, LC-MS analysis was employed to investigate the formation of heavier products that were not sufficiently volatile for analysis by gas-chromatography (GC). The detection parameters were fixed between $m/z = 100\text{--}1000$, and the resulting chromatogram was incredibly complex, which was considered good evidence for the formation of high molecular weight products. In order to determine the total carbon content after reaction, CHN analysis was also performed on the post reaction solution. When the results from CHN analysis, any gaseous products and coke deposition were accounted for, the total carbon balance was found to be 94% for a 50 wt.% feedstock, with the missing carbon attributed to reactor fouling. Since these high molecular weight products are not involved in the formation of methanol, reducing the formation of these products is considered crucial in maximising methanol production from glycerol.

A combined periodic DFT and QM/MM approach was employed to provide further insights into the reaction mechanism over MgO [56], particularly the final step required for the production of methanol, which is the reduction of a hydroxymethyl radical. In the periodic DFT models PBEsol and PBEsol+D3 functionals were used to establish the importance of dispersion interactions between adsorbates and the oxide. The QM/MM calculations used a combination of PBE0 and shell model potentials allowing the differences between pure GGA and hybrid functionals to be established. A number of possible hydrogen donors were considered, including glycerol itself, ethylene glycol and hydroxyacetone as shown in Figure 2. Furthermore, investigated were water, methanol and the hydroxymethyl radical.

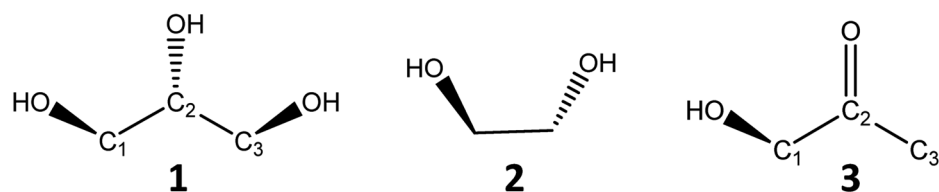

Figure 2. Organic molecules with labelled atom positions that were investigated as H-donors for the reduction of a hydroxymethyl radical to methanol. Reproduced from ref. [56] with permission from the Royal Society of Chemistry.

Both periodic and QM/MM approaches showed the use of water as the hydrogen source for the reduction of the hydroxymethyl radical is energetically unfavourable, thus,

water is unlikely to be the required hydrogen source. Interestingly, the disproportionation of two hydroxymethyl radicals to give one methanol and one formaldehyde molecule was calculated to be the lowest energy route for methanol production. The presence of formaldehyde in the post-reaction feed was determined by HPLC. Due to challenges analysing formaldehyde, the reaction mixture was reacted over an LpDNPH cartridge coated with 2,4-dinitrophenylhydrazine, leading to the formation of a formaldehyde-hydrazone derivative, confirmed by comparison with a formaldehyde-hydrazone calibration standard.

The effect of reaction temperature and catalyst mass were also investigated using commercially available ceria [57]. Similarly to the reactions performed with MgO, at 320 °C, hydroxyacetone was the main product formed (49%) with significant quantities of 1,2-propanediol and ethylene glycol also observed. Selectivity to these products decreased as the reaction temperature increased, as a result of increased methanol, acetaldehyde, acetone and CO_x selectivities. Increasing the catalyst mass, at a temperature of 320 °C, from 0.5 to 1.5 g resulted in comparable methanol STYs, although this reduced upon increasing the mass further to 4 g. Carbon balances of 100% were achieved with 0.5 and 1.5 g, but this was reduced to 92% with 4 g of catalyst, confirming that the increased mass, and consequently contact time, was detrimental to methanol production, likely due to an increase in side reactions and by-product formation.

The commercially available ceria had a low surface area (8 m² g⁻¹), thus relatively high reaction temperatures (>400 °C) were required for effective methanol production. Consequently, a series of CeO₂ catalysts were prepared by altering the calcination temperature to investigate the influence of ceria surface area and crystallite size on product distribution and methanol selectivity. A cerium hydroxide precursor was calcined at temperatures between 400 °C and 700 °C, resulting in materials with surface areas between 38 and 22 m² g⁻¹. These materials were then tested with a constant surface area across the materials, achieved by adjusting the mass of catalyst to normalise the surface area. The flow rate of the inert carrier gas was also adjusted to ensure that the space velocity was kept constant between experiments. Under these conditions, there were no notable differences in glycerol conversion or product distribution. Characterisation of the materials showed that the crystallite size increased with increasing temperature, which was accompanied by a reduction in defect density, although no clear relationship between the obtained product distribution and the physicochemical properties of the ceria catalysts could be established.

Whilst the previous study into the effect of ceria calcination temperature showed no clear correlation between the defect site density present in the ceria catalyst and the reactivity of glycerol and/or intermediate products, it is worth noting that the overall defect density was low across all samples. The defect density of ceria can strongly influence the oxygen storage capacity (OSC) of the material, which has been strongly correlated with catalytic activity for a number of reactions. One strategy that has been utilized to increase the OSC of ceria-based materials is the inclusion of dopants. Tetravalent dopants such as Zr⁴⁺ have been extensively studied; since Zr⁴⁺ and Ce⁴⁺ have different ionic radii, the replacement of Ce⁴⁺ ions by Zr⁴⁺ ions leads to distortion within the ceria lattice, enhancing oxygen mobility within the material. The inclusion of aliovalent dopants such as La³⁺ or Pr³⁺ leads to the formation of oxygen vacancies to maintain a neutral charge, which often results in the reduction of nearby Ce⁴⁺ ions to Ce³⁺ ions leading to increased defect density and OSC. Consequently, a series of ceria based solid solutions were prepared and employed as catalysts for the conversion of glycerol to methanol, alongside CeO₂, ZrO₂ and Pr₆O₁₁ (Table 2) [58].

Table 2. Activity of Ce-Zr and Ce-Pr solid solutions. Data reproduced from ref. [58] with permission from the Royal Society.

Catalyst	Conversion (%)	Major Product Selectivity (%)				Specific Activity /mmol _{MeOH} h ⁻¹ m ⁻²	Intrinsic Activity /g _{MeOH} h ⁻¹ kg ⁻¹
		MeOH	HAc	AceA	CO _x		
CeO ₂	99.8	12.6	6.4	8.7	13.1	0.052	96.86
Ce ₃ ZrO ₂	97.7	11.5	9.3	11.9	8.5	0.032	94.98
CeZrO ₂	99.9	11.4	13.0	11.0	6.9	0.029	101.76
ZrO ₂	67.9	7.9	30.5	7.7	5.1	0.013	37.17
Ce ₃ PrO ₂	90.6	12.1	10.8	8.8	11.8	0.039	100.38
CePrO ₂	74.3	12.9	19.2	9.4	9.0	0.076	70.44
Pr ₆ O ₁₁	64.4	10.6	23.0	6.7	4.8	0.042	65.08

MeOH = methanol; HAc = hydroxyacetone; AceA = acetaldehyde; CO_x = CO & CO₂ combined.

Comparable levels of glycerol conversion were achieved over CeO₂, Ce₃ZrO₂ and CeZrO₂ (ca. 99%) with a notably lower conversion over ZrO₂. The inclusion of Zr⁴⁺ resulted in a slight decrease in methanol selectivity, alongside increased acetaldehyde and acrolein selectivity; relatively high acrolein selectivity (12%) was achieved over ZrO₂. Very similar levels of methanol selectivity were achieved over CeO₂, Ce₃PrO₂ and CePrO₂, at glycerol conversions of 99%, 91% and 65%, respectively. As glycerol selectivity typically increased with increasing conversion, these results suggest that the incorporation of Pr^{3+/4+} is beneficial for methanol production. Once normalised to surface area, the methanol formation rate over CePrO₂ (0.076 mmol_{MeOH} m⁻² h⁻¹) was significantly higher than over CeO₂ (0.052 mmol_{MeOH} m⁻² h⁻¹) or any of the other compositions tested. With the exception of Pr₆O₁₁, which showed relatively low rates of methanol formation, the highest degree of reducibility was calculated for CePrO₂, along with a high density of defects measured by Raman spectroscopy. The comparatively low activity of Pr₆O₁₁, despite the high degree of reducibility, suggests that it is the combination of both Ce and Pr in a solid solution in the CePrO₂ sample that is beneficial to methanol production, although further work is required to understand this effect fully.

In an attempt to gain deeper insights into the role of ceria in the production of methanol from glycerol, a series of catalysts with well-defined morphologies were synthesised to explore the role of ceria morphology and exposed surface plane on glycerol conversion and methanol selectivity [59]. Following a procedure first published by Yan and co-workers [60], ceria nanocubes (Ce-C), nanorods (Ce-R) and nanopolyhedra (Ce-P) were synthesised through a hydrothermal route using Ce(NO₃)₃ and NaOH by varying the base concentration and synthesis temperature. HRTEM showed that the (100) surface was preferentially exposed by Ce-C, with the (110) and (100) surfaces exposed by Ce-R, and the (111) and (100) surface planes exposed by Ce-P. These materials were subsequently evaluated for the transformation of glycerol to methanol under a variety of conditions.

At a constant GHSV, glycerol conversion was shown to follow the trend; Ce-R > Ce-P > Ce-C, which followed the trend of their respective surface areas of 85, 65 and 23 m² g⁻¹. At a temperature of 320 °C, where no conversion occurs in the absence of a catalyst, glycerol conversion was constant over the three catalysts once normalised to surface area, indicating the surface area of a ceria strongly influences conversion. At all given temperatures, methanol selectivity was significantly lower over Ce-C than Ce-R and Ce-P, but given the much lower glycerol conversions achieved over Ce-C, it was difficult to attribute this to morphology or surface plane preferentially exposed.

In order to explore the role of surface facet on product distribution without the influence of glycerol conversion, GHSVs were altered to achieve *iso*-conversion of ca. 15%. As a glycerol conversion of 17% was obtained over Ce-C at a space velocity of 3600 h⁻¹ and a reaction temperature of 320 °C, the space velocities over Ce-P and Ce-R were adjusted to 9000 and 11,250 h⁻¹, respectively, leading to conversions of 16% and 14%. Given the comparable levels of glycerol conversion, product distributions could be directly compared across the materials. Hydroxyacetone was detected as the major product over Ce-R and Ce-P, with selectivities of 37% and 44%, respectively, although this was notably lower over

Ce-C at 14%. A relatively high acrolein selectivity (14%) was observed over Ce-C, compared with Ce-R (3%) and Ce-P (2%), which was indicative of differences in reaction mechanism. Hydroxyacetone is formed through dehydration at a terminal alcohol position, in contrast to acrolein, which is initiated via dehydration at the secondary position. Additionally, selectivity to 1,2-propanediol (formed via hydroxyacetone hydrogenation) was noticeably higher than 1,3-propanediol (formed via 3-hydroxypropanal reduction) over Ce-R and Ce-P, whereas the reverse was true for Ce-C. These differences in product distribution suggest that dehydration initially occurs at the C₁ position over Ce-R and Ce-P (Scheme 3), in contrast to Ce-P where dehydration at the C₂ position seems more dominant (Scheme 4).

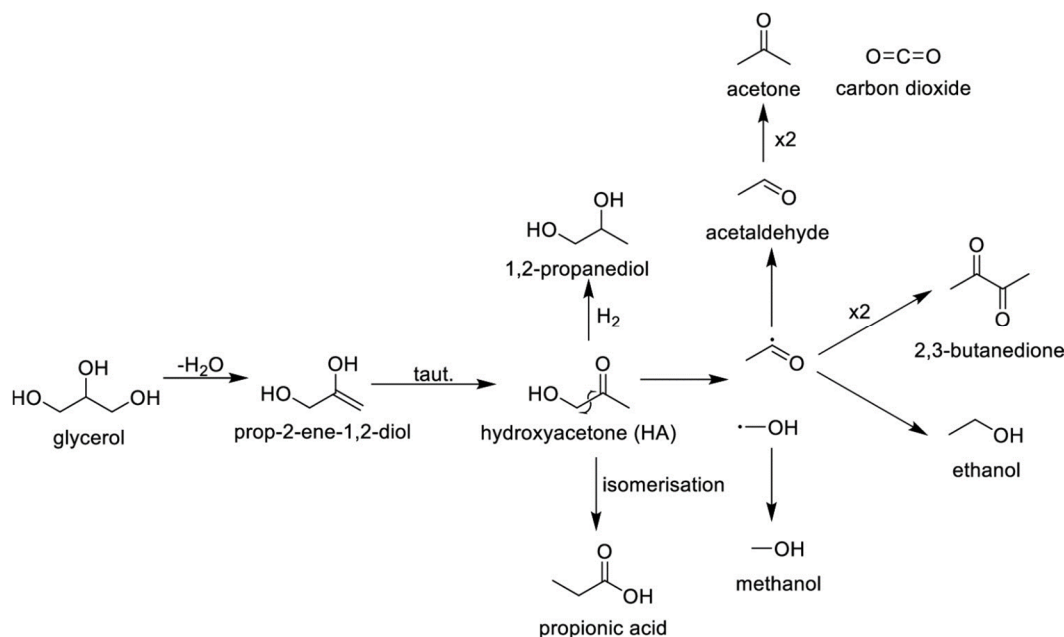

Scheme 3. Reaction scheme initiated by dehydration at the C₁ position of glycerol. Scheme reproduced from ref. [59] with permission from the American Chemical Society.

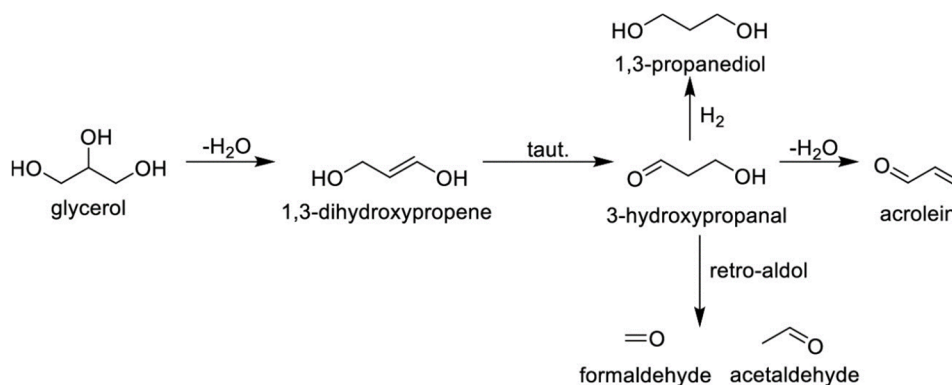

Scheme 4. Reaction scheme initiated by dehydration at the C₂ position of glycerol. Scheme reproduced from ref. [59] with permission from the American Chemical Society.

Similar reactions were also performed at a temperature of 400 °C with an increased mass of Ce-C, in order to achieve high conversion over all materials; as a terminal product, high selectivity to methanol is generally observed only at almost complete levels of glycerol conversion. Conversions of >99% were achieved over Ce-R and Ce-P at a space velocity of 3600 h⁻¹, so the GHSV was adjusted to 1800 h⁻¹ to achieve a comparable level over Ce-C. At this high level of conversion, methanol selectivity had the order; Ce-P > Ce-R >> Ce-C, and the selectivities were 25%, 23% and 13%, respectively. These corresponded to 201, 164

and $47 \text{ g}_{\text{MeOH}} \text{ h}^{-1} \text{ kg}_{\text{cat}}^{-1}$ STYs. This mirrored the same trend as the hydroxyacetone STY, illustrated in Figure 3, where a strong relationship between high hydroxyacetone STY at low conversion and high methanol STY at high conversion was demonstrated. The low selectivity to methanol was attributed to the divergence in reaction mechanism with dehydration at the C₂ position, since this reaction pathway does not result in methanol production.

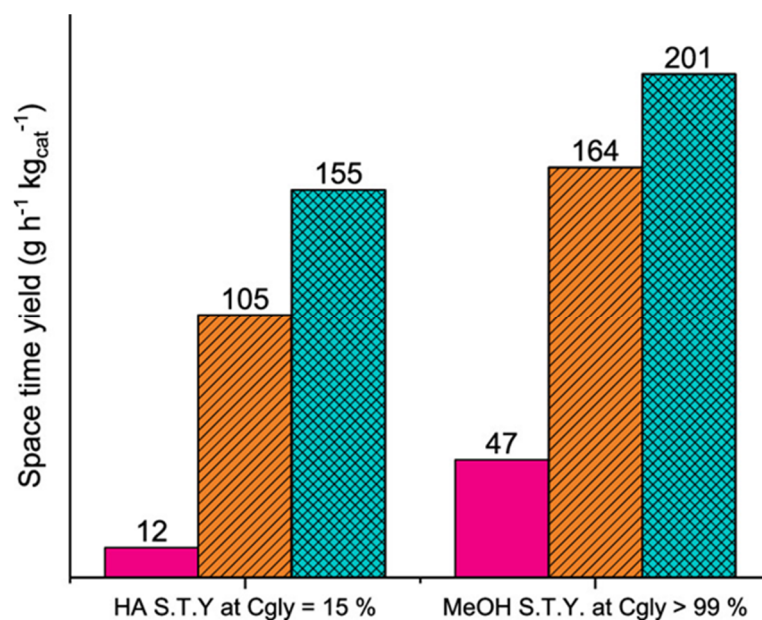

Figure 3. “Hydroxyacetone and methanol STYs over Ce-C (pink), Ce-R (orange lined), and Ce-P (blue hatched), where catalyst mass and carrier flow rates were altered to achieve glycerol conversions of ca. 15% and >99%. Low conversion reactions performed at 320 °C; high conversion reactions performed at 400 °C and GHSVs between 1800 and 11,250 h⁻¹.” Figure and caption reproduced from ref. [59] with permission from the American Chemical Society.

Calculations applying DFT suggest that under reaction conditions, the (100) surface is most likely fully hydroxylated, in contrast to the (110) and (111) surfaces where hydroxylation is unfavourable. Since the (100) surface is preferentially exposed in Ce-C, it appears that surface hydroxylation of ceria is not beneficial for the formation of methanol, and it may influence the reaction pathway. Interestingly, the high defect density present in Ce-R did not appear to promote methanol production, as it was Ce-P, with the lowest defect density, that resulted in the highest methanol selectivity. Additionally, the (111) surface, which is the most thermodynamically stable of the low index ceria surfaces, exposed by Ce-P appears to have a positive effect on methanol formation. These insights should be considered in any further attempts to optimise ceria-based catalysts for the conversion of glycerol to methanol.

2.2. VAIPs for Glycerol to Methanol

The conversion of glycerol to methanol in the absence of external hydrogen has also been demonstrated over VAIPs (vanadium substituted aluminophosphate materials, with V loadings between 5–10 wt.%) [61]. A maximum methanol selectivity of 84.6% was reported over V7.5APO, which has a vanadium loading of 7.5%. The high methanol selectivity observed over this catalyst was attributed to the high levels of V⁴⁺ present in the sample, which the authors claimed to be the active site for the C-C cleavage required to form methanol. Other major observed products were acetaldehyde and dihydroxyacetone, the latter of which is unsurprising since O₂ was co-fed into the reactor alongside glycerol. Interestingly, of all the catalysts which were investigated, the maximum methanol selectivity was found to be at an oxygen:glycerol molar ratio of 2.6:1, which seems surprising since the conversion of glycerol to methanol is a reductive process overall. In contrast to the

conversion of glycerol to methanol over basic and redox catalysts discussed above, over VAIPOs, methanol selectivity was found to increase with increasing temperatures (between 200 and 350 °C), whereas acetaldehyde selectivity was shown to decrease. Additionally, the use of hydroxyacetone as a feedstock for the reaction did not result in methanol production, indicating that the mechanism for the conversion of glycerol to methanol over VAIPOs varies significantly compared to that over CeO₂ or MgO. Notably, the authors did not appear to quantify gaseous products formed. Given that these reactions are conducted under aerobic conditions, it's likely that a significant proportion of CO₂ is produced.

2.3. The Super Methanol Concept

An alternative route to the production of methanol from glycerol, known as the Supermethanol concept, has also been demonstrated [62]. This integrated process combines glycerol reforming in supercritical water with methanol synthesis, utilizing the syngas produced from glycerol. The highly refined reactor configuration employed is presented in Figure 4. A Ni/CaO-Al₂O₃ catalyst was used for glycerol reforming, operated at temperatures of 675–725 °C with pressures in the range 240–270 bar. After separation of liquid and gas phases, the gas stream was fed directly over a Cu/ZnO/Al₂O₃ methanol synthesis catalyst at temperatures in the range 195–245 °C and the same pressures as above [63]. The gas composition following the reforming step was shown to have a strong influence on the final methanol yield, with hydrocarbon formation shown to be highly detrimental to the process. The maximum reported methanol yield of 60% was achieved with temperatures of 725 °C and 208 °C for the reforming and methanol synthesis reactions, respectively, both at 260 bar. Nevertheless, the conditions required to achieve such yields can be considered very harsh, particularly given the use of supercritical water for glycerol reforming. Supercritical water, due to its exceptionally corrosive nature, is extremely hazardous, and could pose a number of challenges for upscaling of this technology. Furthermore, given the heterogeneous nature of crude glycerol, achieving good control of the gas stream composition via reforming may prove challenging.

2.4. Glycerol to Ethanol

Kostyniuk et al. [64] recently reported the conversion of glycerol to ethanol over caesium-promoted ZSM-5 catalysts. The process was similar to that of glycerol to methanol originally reported by Haider et al. [39]. The initial step of glycerol dehydration gives hydroxyacetone, which can undergo a radical fragmentation to produce hydroxymethyl and acetyl radicals, with the acetyl radical reduced to yield ethanol. Interestingly, the reduction of acetaldehyde to ethanol was not one of the routes to ethanol, nor was glycidol decomposition. The authors proposed that methanol dehydration could also occur giving methylene, a carbene radical, which subsequently reacts with methanol via a methylation reaction, resulting in ethanol production. This route was confirmed by the use of methanol as a reactant for the process, as ethanol was the only detected liquid phase product. The observed reaction rates for the methylation of methanol were found to be relatively low, thus this route was considered to be a minor reaction pathway.

The authors reported that a ethanol yield of 99.6 mol.% could be achieved over a 20 wt.% CsZSM-5(1500) catalyst, in a vapor phase process operated at 350 °C with a 10 wt.% aqueous glycerol feedstock for a period of 2 h on-stream. This is, however, slightly misleading, as this calculation does not account for all of the carbon present in glycerol. Nevertheless, the exceptional selectivity exhibited provides an ethanol carbon yield of ca. 66%. Over a reaction period of 50 h, a notable reduction in conversion was observed during the initial 20 h of the reaction, stabilising at ca. 40%, although an ethanol selectivity of 91 mol.% was maintained over this period. A different product distribution was obtained over a 20 wt.% CsZSM-5(1500) catalyst, with hydroxyacetone, allyl alcohol and glycidol observed as the main products (Scheme 5). High levels of coke deposition were also detected over CsZSM-5(30) in contrast to CsZSM-5(1500).

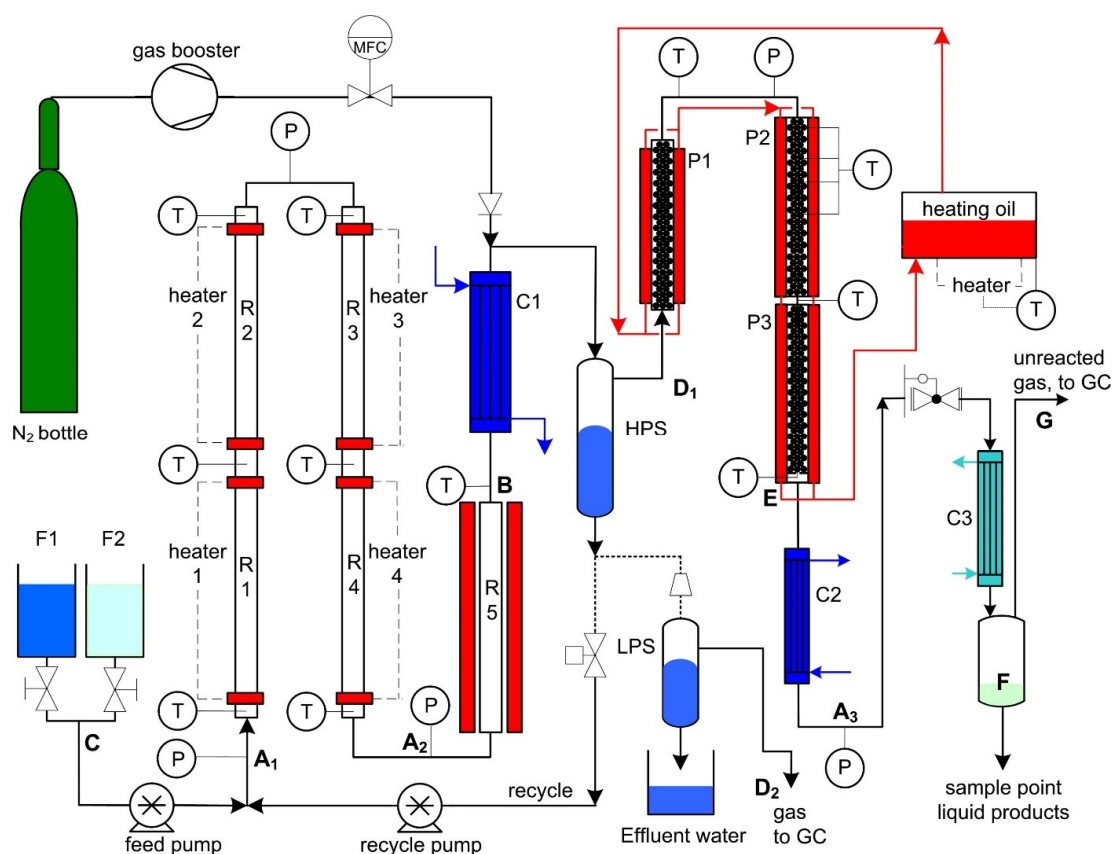
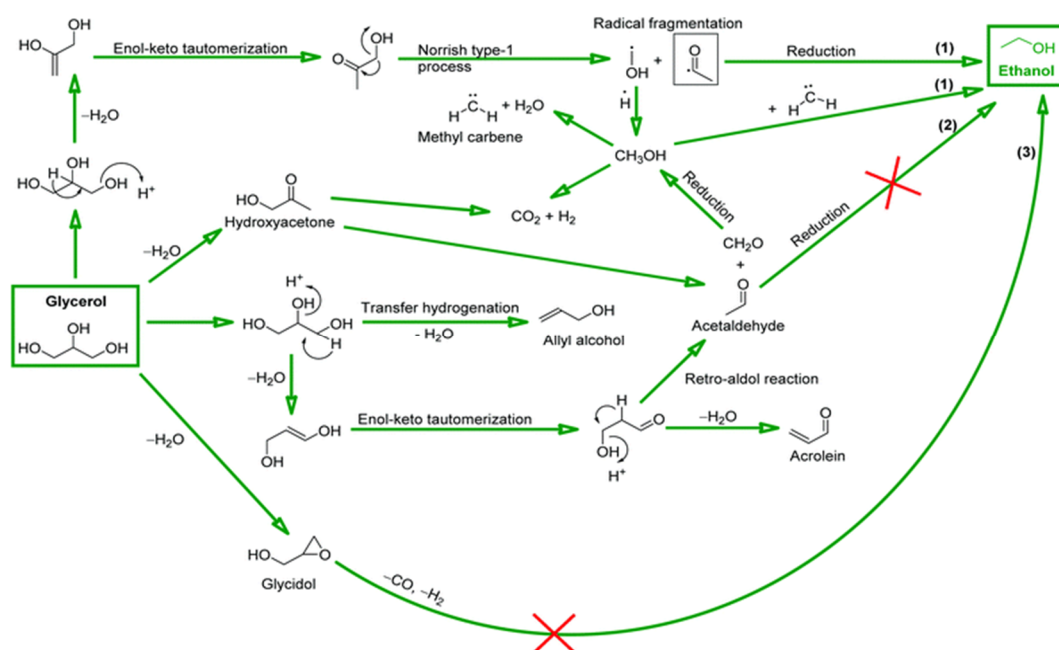

Figure 4. The reactor configuration used for the synthesis of methanol from glycerol. The process is separated into two distinct catalysed reactions: (i) Glycerol reforming to produce syngas and (ii) methanol synthesis. Reproduced from ref. [63] with permission from Elsevier.



Scheme 5. Proposed reaction mechanism for the conversion of glycerol to ethanol over CsZSM-5 catalysts. Reproduced from ref. [64] with permission from the Royal Society of Chemistry.

The excellent ethanol selectivity achieved over CsZSM-5(1500) was attributed to two factors: (1) The complete absence of acid sites, as determined by NH_3 -TPD and pyridine-DRIFTS experiments, and suitable density of base sites, measured by CO_2 TPD; (2) the smaller crystallite size and strong synergy between the ZSM-5(1500) and Cs. The remarkably different product distributions and degrees of catalyst coking highlight the importance of carefully controlling the acid-base properties in such a process.

2.5. Glycerol to Mono Alcohols via Hydrogenolysis

Glycerol hydrogenolysis has also been identified as an alternative route for the production of methanol and other mono-alcohols from glycerol. Hydrogenolysis involves the cleavage of C-C or C-O through the addition of H_2 . As a biobased molecule, glycerol has a higher O/C ratio than typical fossil-fuel derived molecules, thus glycerol hydrogenolysis favouring C-O cleavage can be used to reduce the relative oxygen content. The majority of reports have focussed on the production of 1,2-propanediol and 1,3-propanediol, both of which are useful commodity chemicals [12,13,65,66]. The majority of glycerol hydrogenolysis studies involve the addition of external H_2 and operate at significantly higher pressures than the glycerol to methanol (or ethanol) process, discussed in detail above. Glycerol hydrogenolysis has been extensively reviewed over recent years [23,67–69]. As this work is focused on the conversion of glycerol to alcohols in the absence of external H_2 , we do not discuss glycerol hydrogenolysis in detail, however, due to the importance of the topic, we consider it prudent to briefly discuss the reports of glycerol hydrogenolysis which focus on the production of mono-alcohols.

Friedrich and co-workers reported the use of Ni catalysts supported on silica or alumina for the conversion of glycerol to mono-alcohols, although methanol selectivity was typically low (<5% under all conditions tested) [70]. A total selectivity to mono-alcohols of 54.5% was observed over $\text{Ni}/\text{Al}_2\text{O}_3$, compared with 68.5% over Ni/SiO_2 . These reactions were conducted at a reaction temperature of 320 °C with a 60 wt.% glycerol feedstock (GHSV of 1060 h^{-1}) and a H_2 pressure of 60 bar. The authors attributed the higher activity of Ni/SiO_2 to the stronger metal-support interactions compared with $\text{Ni}/\text{Al}_2\text{O}_3$, resulting in an increased density of Ni sites. Further work from the group focussed on the use of supported molybdenum and tungsten catalysts [71]. Higher activities were observed over Al_2O_3 supported catalysts compared with SiO_2 , which was attributed to the higher degree of Brønsted acidity of the alumina catalysts. Increasing both reaction temperature and H_2 :glycerol ratio resulted in increased selectivity towards mono-alcohols at the expense of diols such as ethylene glycol and 1,2-propanediol, with higher degrees of reduction favoured under harsher conditions. A maximum lower alcohol selectivity was observed at 320 °C and a H_2 pressure of 60 bar over 10 wt.% $\text{W}/\text{Al}_2\text{O}_3$, with a methanol selectivity of ca. 35%. The Friedrich group also explored the use of Re-Ni catalysts supported on both silica and alumina for the conversion of glycerol to mono-alcohols [72]. Similarly to previous studies, an increase in reaction temperature was shown to result in an increase in mono-alcohols, such as methanol and 1-propanol, as a consequence of reduced 1,2-propanediol and ethylene glycol selectivity. Interestingly, a strong correlation between glycerol conversion and catalyst acidity was observed, with the most acidic $\text{Re-Ni}/\text{Al}_2\text{O}_3$ catalysts resulting in the highest selectivity to 1-propanol. In contrast to ethanol and propanol, selectivity to methanol was found to decrease with increasing H_2 pressure, which was attributed to the further reaction of methanol.

The conversion of crude glycerol to 1-propanol, with yields of 79%, has recently been reported [73] in a batch process employed a bi-functional catalytic system comprising both $\text{Ni}/\gamma\text{-Al}_2\text{O}_3$ and $\text{Ni}/\text{CS-P}$ catalysts, where CS-P represents a phosphorus-impregnated carbon composite. A selectivity to 1-propanol of 71% was achieved using crude glycerol, with a catalyst to glycerol mass ratio of 0.16, a reaction temperature of 260 °C and a pressure of 65 bar. The 1-propanol yield could be further improved by operating the process in two individual steps: (1) crude glycerol hydrogenolysis to 1,2-propanediol over $\text{Ni}/\gamma\text{-Al}_2\text{O}_3$ at 220 °C and (2) 1,2-propanediol hydrogenolysis over $\text{Ni}/\text{CS-P}$ to yield 1-propanol. The

high activity of Ni/ γ -Al₂O₃ with regard to glycerol hydrogenolysis was attributed to the presence of small metallic Ni particles that strongly interact with the acid sites of the support. Characterisation of the Ni/CS-P catalyst showed the presence of a Ni₂P phase, which along with the AlPO_x species, were thought to be responsible for the high acidity which promoted C-O cleavage at the secondary position of 1,2-propanediol, leading to high yields of 1-propanol.

3. Update on the Valorization of Crude Glycerol

Almost all the research articles discussed so far have relied on the use of pure glycerol (PG) as a feedstock. The CG derived from biodiesel synthesis is however, chemically, very different to PG. In a recent study, where 11 samples were taken from 7 different biodiesel manufacturers, the glycerol purity was determined to vary from 38 to 96% [74]. In addition to variations in glycerol purity, CG can comprise of a range of other impurities [75], such as: (i) residual FAME, (ii) residues from transesterification catalysts (typically KOH or NaOH), (iii) residual alcohol reagent (typically methanol or ethanol), (iv) matter organic not glycerol (MONG), (v) ash and (vi) water. The relative composition of CG is typically dependent on the triglyceride source and the process conditions used at the biodiesel synthesis plant from which it is acquired [75,76]. Collectively, these impurities represent a significant challenge for process commercialisation. This is particularly relevant to valorisation processes which rely on the use of heterogeneous catalysts, as these materials are often highly susceptible to deactivation through active site poisoning [77].

For this reason, extensive research has focussed on developing efficient methods of purifying CG. Ardi et al. [78] reviewed progress in this area in 2015 and highlighted the outstanding challenges. The authors discussed a variety of purification methods, including: vacuum distillation, ion exchange, membranes, activated carbon filtration and chemical treatment. Despite concluding that there were several promising emerging technologies, the authors stated that vacuum distillation would continue to be the primary method of purifying glycerol on a large scale. Although highly effective, this purification method is exceptionally expensive. This raises the question as to whether adopting such a strategy would be economically feasible. Ideally, valorisation processes would be comparable with CG feedstocks.

In 2016, Kong et al. [79] published an important review article that compared the conversion of PG and CG into various derivatives. The authors identified several valorisation processes that may be feasible to use CG as feedstock. These were: hydrogen production through steam reforming, glycerol hydrochlorination to produce epichlorohydrin and glycerol polymerisation. Following this review, numerous other studies have been conducted using CG as feedstock. Table 3 lists several of these studies and where possible, the difference in catalytic performance between using CG and PG is compared.

The catalytic hydrogenolysis of CG to 1,2-PDO has been investigated independently in batch and continuous conditions over supported Cu catalysts [80,81]. Both research articles noted a drop in performance when CG was used in place of PG, which in both cases was attributed to impurities inhibiting catalyst function. Gatti et al. [73] developed a two-step batch process for the conversion of CG into 1-propanol, which proceeded via 1,2-propanediol. The authors noted that comparable 1-propanol yields were observed when CG and PG were used as feedstock. Wu et al. extended this to the synthesis of propylene from CG in continuous flow [82]. The authors combined two catalysts; a MoO₃ modified Ni₂P/Al₂O₃ catalyst (used for the hydrogenolysis of glycerol to 1-propanol), and a ZSM-5 catalyst (used to crack the remaining C-O bond). A significant drop in performance was observed when PG was replaced with a synthetic CG feed. However, the loss in performance could in part be recovered by using a more acidic ZSM-5 zeolite. Several groups have also investigated the aerobic oxidation of CG into lactic acid. Activated carbon (AC) supported Pt and Pd catalysts [84], and transition metal heteropolyacid catalysts [83] were both demonstrated to be effective. However, notable losses in lactic acid yields were observed when PG was replaced with CG. For the AC supported catalysts, larger losses

in yield were observed (15–30%), which the authors attributed to salt and ash impurities from the CG. Finn et al. [94] also demonstrated that homogeneous sulphonated Ir and Ru carbene-containing catalysts could be effective for this process. The most effective catalyst exhibited almost an identical TOF for both PG and CG, 42,592 and 41,893 h⁻¹, respectively.

The etherification and acetalization of CG have also been examined. Chiosso et al. [88] used SO₃H functionalised carbons to catalyse CG etherification with benzyl alcohol under batch conditions. The authors noted that the residual water present in the CG was extremely detrimental to catalyst performance. Hameed and co-workers also investigated the formation of fuel additives, di- and triacetin, through reacting CG with acetic acid over sulphonated carbon catalysts [95]. While the authors did not make any comparisons with PG feeds, under batch operation the catalyst performance appeared to be stable for up to seven uses. In a separate study, Bedogni et al. [96] demonstrated that using CG did not influence catalyst selectivity, but did negatively impact on reaction rate over solid acid catalysts. Tarighi and co-workers also demonstrated that hierarchical faujasite zeolite-supported heteropoly acids were effective for the acetylation of synthetic crude glycerol (SCG) with acetone, into solketal [90]. The authors determined that methanol (present in the SCG) had very little impact on the catalysis, but NaCl was found to dramatically inhibit the solketal yield. Separately, Tathod et al. [97] confirmed that solketal could be produced from CG in a similar manner using a metal-free mordenite catalyst. The authors determined that the catalyst exhibited a good tolerance to water and other impurities in the CG, reflected by the fact that the catalytic performance was maintained for up to three uses.

A variety of studies have focussed on reacting CG with nitrogen containing compounds. Wang et al. [87] demonstrated that, under batch conditions, alanine yields of up to 43% could be acquired from CG over a Ru₁Ni₇/MgO catalyst. The authors conducted reusability experiments with CG and determined that the activity could be maintained up to three uses. The authors suggested that the subsequent decrease in activity was not attributed to impurities in the CG, but particle sintering. Separately, Akula and co-workers published two papers on the continuous formation of 2,6-dimethylpyrazine from reacting CG with 1,2-propanediamine over supported Cu catalysts. In the first paper, the authors assessed how the synthesis procedure of CuCr₂O₄ catalysts influenced their performance [85]. Using a SCG feedstock (which contained water, methanol and KOH), the activity and selectivity of all the investigated catalysts decreased compared to values acquired from identical reactions run using PG. Following on from this, the authors assessed how Zn promoted CuCr₂O₄ catalysts influenced this reaction over a CG feedstock (*Jatropha Curcas*) [86]. Once again, the activity and selectivity was lower with CG; 76.3% selectivity at 12.3% conversion compared to 97.3% selectivity at 37.7% conversion observed with PG. The decrease of performance was attributed to impurities in CG; either KOH inhibiting surface basicity or NaCl blocking active sites.

Given that glycerol dehydration to acrolein is such an active area of research [24,25], we were surprised not to find any examples where CG had been used as a feedstock for this reaction. Lu et al. [89] did however demonstrate that acrylic acid could be produced from CG; a reaction where acrolein is considered to be a key intermediate. Here, the authors demonstrated that a 73% acrylic acid selectivity could be achieved (at 95% conversion) over a CsPW-Nb catalyst under continuous conditions. This was however notably poorer than the performance observed in a comparable reaction run using PG (85% acrylic acid selectivity at 100% conversion). Haider et al. [39] also assessed whether CG could be used as a feedstock for the production of 'green' methanol. As discussed, this reaction proceeds through a dehydration and subsequent radical fragmentation pathway; it is complex and a broad variety of products can be produced. The authors determined that a notable drop in the methanol STY was observed at high glycerol feeds (50 wt.%) when PG was replaced with CG. The authors did however determine that reducing the glycerol wt.% in the feed resulted in closer STYs for methanol with PG and CG. Further stability tests including time on steam are required to assess whether this is a viable approach for the valorisation of CG.

Table 3. List of published transformations (2017 onwards) where crude glycerol (CG) or synthetic crude glycerol (SCG) is used as a feedstock.

Reaction	Target Product	Catalyst(s)	Reactor	Typical conditions	Performance vs. PG	Comments	Ref.
Hydrogenolysis	1,2-Propanediol	(1) 15% Cu/HTC (2) 5% Cu-B/Al ₂ O ₃	(1) Batch (2) Cont.	(1) 200 °C, 3.4 MPa H ₂ ; CG (2) 250 °C; 6 Mpa H ₂ , 0.1 h ⁻¹ WHSV; CG	(1) 13% drop in yield (2) 41% drop in yield	Drop attributed to impurities in crude glycerol	[80,81]
Hydrogenolysis	1-Propanol	Reaction with 2 catalysts: (a) Ni/γ-Al ₂ O ₃ (b) Ni/Cs-P	Batch	2-Step Process: (i) 5 h at 220 °C over Cat (a) (ii) 2 h at 260 °C over Cat (b); CG	Comparable	N/A	[73]
2 step process: (i) Hydrogenolysis (ii) Cracking	Propylene	Reaction with 2 catalysts: (a) MoO ₃ -Ni ₂ P/Al ₂ O ₃ (b) ZSM-5	Cont.	300 °C, WHSV = 1.0 h ⁻¹ ; H ₂ /glycerol = 100, CG	48% drop in yield; can be reduced to an 18% drop with a more acidic ZSM-5	Methanol in CG allows for competing pathway to aromatics and heavy olefins	[82]
Aerobic Oxidation	Lactic Acid	(1) 5% Pt/AC or 10% Pd/AC (2). AlPMo ₁₂ O ₄₀	Batch	(1) 2.2 MPa O ₂ , 230 °C, NaOH, CG (2) 1 Mpa O ₂ , 60 °C, SCG	(1) 15–30% drop in yield. (2) 10% drop in yield	(1) Attributed to impurities (salts and ashes) (2) ND	[83,84]
Dehydrocyclization	2,6-Dimethylpyrazine	(1) CuCr ₂ O ₄ (2) Zn-Cu ₂ O ₄	Cont.	375 °C; Atmospheric Pressure; Propanediamine; (1) GHSV = 11.0 mL gcat ⁻¹ s ⁻¹ ; SCG; (2) 40.25 mL gcat ⁻¹ s ⁻¹ ; CG	(1) 34% drop in yield (2) 74% drop in yield	KOH and NaCl block surface active sites.	[85,86]
Reductive Amination	Alanine	Ru ₁ Ni ₇ /MgO	Batch	220 °C; 1 MPa H ₂ ; NaOH; NH ₃ H ₂ O; CG	Comparable	Particle sintering occurred over successive runs	[87]
Etherification	Mono-, di- and tri-ethers	SO ₃ -Functionalised Carbons	Batch	120 °C, Atmospheric pressure; Glycerol: benzyl alcohol = 3: 1	Glycerol conversion drops from 97% to 20%. Selectivity to unknowns much greater with CG	Attributed to impurities and moisture content in the CG	[88]
Dehydration-Oxidation	Acrylic Acid	Reaction with two catalysts: (a) 20% CsPW-Nb (b) VMo-SiC	Cont.	300 °C; Atmospheric pressure; N ₂ (34 mL min ⁻¹); O ₂ (6 mL min ⁻¹); 20 wt.% glycerol solution at 0.6 mL h ⁻¹ (0.24 h ⁻¹ WHSV).	18% drop in yield after TOS = 10 h; deactivation is more pronounced after TOS = 30 h.	Decrease attributed to deposition of alkali metal ions on dehydration catalyst and decreased total acid sites	[89]
Acetalization	Solketal	Zeolite-supported heteropoly acid (HR/Y-W ₂₀)	Batch	40 °C, atmospheric pressure (air); acetone; SCG;	11% drop in yield	NaCl inhibits the catalyst	[90]
Steam Reforming	H ₂ /CO	Ni-MgO/AC	Cont.	650 °C; 30% aqueous CG fed at 2 mL h ⁻¹ ; atmospheric with Ar; CG	Not compared with PG	Deactivation is attributed to coking and sintering	[91]
(i) Dehydration (ii) Radical Fragmentation	* Methanol	CeO ₂	Cont.	340 °C; Atmospheric pressure of Ar (100 mL min ⁻¹); 50 wt.% aqueous glycerol feed (1 mL h ⁻¹); CG	25% drop in methanol STY	Methanol STY decreases at glycerol wt.% increases.	[39]
(i) Deoxygenation; (ii) Aromatisation	BioBTX (Benzene/Toluene/Xylenes)	ZSM-5/Bentonite	Cont.	550 °C; N ₂ (11 mL min ⁻¹), atmospheric pressure; CG	Not compared with PG	Reversible coke formation. Irreversible deactivation attributed to zeolite structure collapse, loss of acidity	[92]
(i) Deoxygenation; (ii) Aromatisation	BioBTX (Benzene/Toluene/Xylenes)	0.1 Ba-1Zn.ZSM-5	Cont.	420 °C; N ₂ (100 mL min ⁻¹), atmospheric acid; Glycerol WHSV 2 h ⁻¹ ; Methanol; SCG	Not compared with PG	Drop in yield over time on stream attributed to the formation of oxygenates and coke	[93]

Footnote: CG (crude glycerol); SCG (synthetic crude glycerol); PG (pure glycerol); STY (space time yield); TOS (Time on stream); ND (not done); Cont. (continuous); * Published before 2017.

4. Conclusions and Outlook

Several strategies for the continuous production of lower alcohols from glycerol have been discussed. This is a subject that is of great commercial interest, from both environmental and economic perspectives, due to the surplus of glycerol that is predicted to be available and the limited methods that currently exist for producing these chemicals from biomass. Research has demonstrated that these compounds can be produced continuously, through a variety of methods. The hydrogenolysis of glycerol is evidently an effective approach but requires significant hydrogen overpressures which, consequentially, poses a significant economic limitation.

For this reason, the dehydration and radical fragmentation of glycerol into lower alcohols, which has been discussed in detail, can be considered a viable alternative as this can be conducted in an inert carrier gas under atmospheric pressure. This approach is highly effective for the formation of both methanol and ethanol, which can be achieved over simple metal oxide and zeolite-based catalysts, respectively. From the work conducted to date, it's evident that the efficacy of the process is dramatically influenced by the catalyst employed, the reaction conditions and the reactor configuration. Physicochemical catalyst properties, such as surface area, surface defects and exposed facets are clearly important for directing selectivity. In addition to catalytic properties, the process conditions

can also dramatically influence performance; the bed length, the bed temperature and the manner and rate in which glycerol is introduced into the reactor are all important factors to consider.

Despite the potential of this process, significant developments are still needed before it can be considered commercially viable. One key limitation is the broad distribution of products formed. Whilst there are numerous advantages to operating the process in the absence of an external oxidant or reductant, this does limit the control of the obtained product. This problem is further amplified when more concentrated glycerol feedstocks are employed. Another significant concern is the low glycerol partial pressures that are typically used. Given that increasing the concentration of glycerol in the feedstock has such a detrimental impact on the product distribution, increasing glycerol partial pressures is likely to cause similar issues. Given that productivity is limited at the partial pressures currently used and increasing this is likely to impact on selectivity, this poses a significant hurdle to overcome if commercialisation of this process is to be realised.

Economically, the use of CG as a feedstock for valorisation is an incredibly important consideration. Current methods used to purify CG are energy intensive and consequentially, are expensive. For this reason, it would be more viable to develop processes which are compatible with CG as feedstock. Given the significance of this, we considered it important to provide an update (from 2017) on relevant works where CG was used as a feedstock. Two groups confirmed that moderate yields of aromatic bioBTX products could be produced from crude glycerol. This is a particularly interesting approach, as methods for the synthesis of C₆ aromatics from biomass are scarce. The acetalization of CG has also shown some potential, particularly with acetone. In the presence of solid acid catalysts, CG and acetone can react to produce high yields of solketal, a promising fuel additive. The viability of this approach could, however, be greatly improved if this technology were to be transferred into a continuous process.

The viability of using CG as a feedstock in other catalysed processes (aerobic oxidation, hydrogenolysis, etc.) has also been assessed. In most examples, the performance with CG was compared with reactions run using PG. In almost all the examples, CG appeared to inhibit the catalyst performance. This was particularly noticeable in examples where catalysts with well-defined active sites, such as supported metal catalysts, were employed. Moving forward, we propose that more emphasis should be placed on the development of mixed metal oxide catalysts for glycerol valorisation. These materials are likely to be more resilient to the diverse range of impurities present in CG. In terms of assessing process viability, we also recommend that, in general, researchers should conduct more thorough reusability experiments. Most research articles did not assess catalyst reusability when CG was used as the feedstock.

Given that the chemical composition of CG can vary dramatically depending on its source, it's extremely unlikely that a universal catalytic process can be developed. The moisture content, MONG and cationic impurities can affect catalyst function and processes differently. We therefore consider industrial involvement to be critical if process commercialisation is to be realised. Working with the same CG source would provide the consistency required to achieve impactful research outcomes. Researchers can build on acquired knowledge and develop processes and technology which are compatible for specific feedstocks. A second benefit of industrial involvement could involve small changes to preceding transesterification process (if viable to do so). This could be highly beneficial if, for instance, the catalyst used is determined to be highly sensitive to one of the reagents used in the transesterification process. Thirdly, and perhaps most importantly, industrial collaboration would allow for more detailed economic assessments of the processes to be made. This is what ultimately dictates whether a process is viable commercially and thus, communication between academia and industry is critical.

Author Contributions: L.R.S., M.D., K.M., N.F.D., D.J.W., G.J.H. and S.H.T. were involved in planning, writing and finalizing the manuscript. All authors have read and agreed to the published version of the manuscript.

Funding: This research was funded by the EPSRC, grant numbers EP/P033695/1 and EP/L027240/1.

Institutional Review Board Statement: Not applicable.

Informed Consent Statement: Not applicable.

Data Availability Statement: Not applicable.

Acknowledgments: All authors would like to thank the Max Planck Society and Cardiff University for financial support to create the FUNCAT center at Cardiff University.

Conflicts of Interest: The authors declare no conflict of interest.

References

1. Pagliaro, M.; Ciriminna, R.; Kimura, H.; Rossi, M.; Della Pina, C. From Glycerol to Value-Added Products. *Angew. Chem. Int. Ed.* **2007**, *46*, 4434–4440. [CrossRef] [PubMed]
2. Behr, A.; Eilting, J.; Irawadi, K.; Leschinski, J.; Lindner, F. Improved utilisation of renewable resources: New important derivatives of glycerol. *Green Chem.* **2008**, *10*, 13–30. [CrossRef]
3. Varma, R.S.; Len, C. Glycerol valorization under continuous flow conditions-recent advances. *Curr. Opin. Green Sustain. Chem.* **2019**, *15*, 83–90. [CrossRef]
4. Checa, M.; Nogales-Delgado, S.; Montes, V.; Encinar, J.M. Recent Advances in Glycerol Catalytic Valorization: A Review. *Catalysts* **2020**, *10*, 1279. [CrossRef]
5. Zhou, C.-H.; Beltramini, J.N.; Fan, Y.-X.; Lu, G.Q. Chemoselective catalytic conversion of glycerol as a biorenewable source to valuable commodity chemicals. *Chem. Soc. Rev.* **2008**, *37*, 527–549. [CrossRef] [PubMed]
6. Bagnato, G.; Iulianelli, A.; Sanna, A.; Basile, A. Glycerol Production and Transformation: A Critical Review with Particular Emphasis on Glycerol Reforming Reaction for Producing Hydrogen in Conventional and Membrane Reactors. *Membranes* **2017**, *7*, 17. [CrossRef]
7. Ciriminna, R.; Pina, C.D.; Rossi, M.; Pagliaro, M. Understanding the glycerol market. *Eur. J. Lipid Sci. Technol.* **2014**, *116*, 1432–1439. [CrossRef]
8. IEA. *Global Energy Review 2021*; IEA: Paris, France, 2021.
9. Research, B. Market Value of Biodiesel Worldwide in 2019 and 2024 (in Billion U.S. Dollars). Available online: <https://www.statista.com/statistics/1109212/global-market-value-biodiesel/> (accessed on 14 July 2022).
10. IEA. *Tracking Transport Biofuels 2020*; IEA: Paris, France, 2020.
11. Alisson Dias da Silva, R.; Ana Luíza Freitas, F.; Antônio Ésio, B.; Rita Maria de Brito, A.; Luiz Antônio Magalhães, P. *Market Prospecting and Assessment of the Economic Potential of Glycerol from Biodiesel*; IntechOpen: London, UK, 2020.
12. Wang, Y.; Zhou, J.; Guo, X. Catalytic hydrogenolysis of glycerol to propanediols: A review. *RSC Adv.* **2015**, *5*, 74611–74628. [CrossRef]
13. Sun, D.; Yamada, Y.; Sato, S.; Ueda, W. Glycerol hydrogenolysis into useful C3 chemicals. *Appl. Catal. B Environ.* **2016**, *193*, 75–92. [CrossRef]
14. Katryniok, B.; Kimura, H.; Skrzyńska, E.; Girardon, J.-S.; Fongarland, P.; Capron, M.; Ducoulombier, R.; Mimura, N.; Paul, S.; Dumeignil, F. Selective catalytic oxidation of glycerol: Perspectives for high value chemicals. *Green Chem.* **2011**, *13*, 1960–1979. [CrossRef]
15. Feng, S.; Yi, J.; Miura, H.; Nakatani, N.; Hada, M.; Shishido, T. Experimental and Theoretical Investigation of the Role of Bismuth in Promoting the Selective Oxidation of Glycerol over Supported Pt–Bi Catalyst under Mild Conditions. *ACS Catal.* **2020**, *10*, 6071–6083. [CrossRef]
16. Walgode, P.M.; Faria, R.P.V.; Rodrigues, A.E. A review of aerobic glycerol oxidation processes using heterogeneous catalysts: A sustainable pathway for the production of dihydroxyacetone. *Catal. Rev.* **2021**, *63*, 422–511. [CrossRef]
17. Evans, C.D.; Douthwaite, M.; Carter, J.H.; Pattison, S.; Kondrat, S.A.; Bethell, D.; Knight, D.W.; Taylor, S.H.; Hutchings, G.J. Enhancing the understanding of the glycerol to lactic acid reaction mechanism over AuPt/TiO₂ under alkaline conditions. *J. Chem. Phys.* **2020**, *152*, 134705. [CrossRef] [PubMed]
18. Douthwaite, M.; Powell, N.; Taylor, A.; Ford, G.; López, J.M.; Solsona, B.; Yang, N.; Sanahuja-Parejo, O.; He, Q.; Morgan, D.J.; et al. Glycerol Selective Oxidation to Lactic Acid over AuPt Nanoparticles; Enhancing Reaction Selectivity and Understanding by Support Modification. *ChemCatChem* **2020**, *12*, 3097–3107. [CrossRef]
19. Gabrysch, T.; Peng, B.; Bunea, S.; Dyker, G.; Muhler, M. The Role of Metallic Copper in the Selective Hydrodeoxygenation of Glycerol to 1,2-Propanediol over Cu/ZrO₂. *ChemCatChem* **2018**, *10*, 1344–1350. [CrossRef]
20. Feng, Y.-S.; Liu, C.; Kang, Y.-M.; Zhou, X.-M.; Liu, L.-L.; Deng, J.; Xu, H.-J.; Fu, Y. Selective hydrogenolysis of glycerol to 1,2-propanediol catalyzed by supported bimetallic PdCu-KF/γ-Al₂O₃. *Chem. Eng. J.* **2015**, *281*, 96–101. [CrossRef]
21. Wang, C.; Jiang, H.; Chen, C.; Chen, R.; Xing, W. Solvent effect on hydrogenolysis of glycerol to 1,2-propanediol over Cu–ZnO catalyst. *Chem. Eng. J.* **2015**, *264*, 344–350. [CrossRef]
22. Wu, F.; Jiang, H.; Zhu, X.; Lu, R.; Shi, L.; Lu, F. Effect of Tungsten Species on Selective Hydrogenolysis of Glycerol to 1,3-Propanediol. *ChemSusChem* **2021**, *14*, 569–581. [CrossRef]

23. Nakagawa, Y.; Tamura, M.; Tomishige, K. Perspective on catalyst development for glycerol reduction to C3 chemicals with molecular hydrogen. *Res. Chem. Intermed.* **2018**, *44*, 3879–3903. [[CrossRef](#)]
24. Katryniok, B.; Paul, S.; Capron, M.; Dumeignil, F. Towards the Sustainable Production of Acrolein by Glycerol Dehydration. *ChemSusChem* **2009**, *2*, 719–730. [[CrossRef](#)]
25. Katryniok, B.; Paul, S.; Dumeignil, F. Recent Developments in the Field of Catalytic Dehydration of Glycerol to Acrolein. *ACS Catal.* **2013**, *3*, 1819–1834. [[CrossRef](#)]
26. Sun, D.; Yamada, Y.; Sato, S.; Ueda, W. Glycerol as a potential renewable raw material for acrylic acid production. *Green Chem.* **2017**, *19*, 3186–3213. [[CrossRef](#)]
27. Nanda, M.R.; Zhang, Y.; Yuan, Z.; Qin, W.; Ghaziaskar, H.S.; Xu, C. (Catalytic conversion of glycerol for sustainable production of solketal as a fuel additive: A review. *Renew. Sustain. Energy Rev.* **2016**, *56*, 1022–1031. [[CrossRef](#)]
28. Talebian-Kiakalaieh, A.; Amin, N.A.S.; Najaafi, N.; Tarighi, S. A Review on the Catalytic Acetalization of Bio-renewable Glycerol to Fuel Additives. *Front. Chem.* **2018**, *6*, 573. [[CrossRef](#)] [[PubMed](#)]
29. Goyal, S.; Hernández, N.B.; Cochran, E.W. An update on the future prospects of glycerol polymers. *Polym. Int.* **2021**, *70*, 911–917. [[CrossRef](#)]
30. Fasolini, A.; Cespi, D.; Tabanelli, T.; Cucciniello, R.; Cavani, F. Hydrogen from Renewables: A Case Study of Glycerol Reforming. *Catalysts* **2019**, *9*, 722. [[CrossRef](#)]
31. Macedo, M.S.; Soria, M.; Madeira, L.M. Process intensification for hydrogen production through glycerol steam reforming. *Renew. Sustain. Energy Rev.* **2021**, *146*, 111151. [[CrossRef](#)]
32. Freitas, I.C.; Manfro, R.L.; Souza, M.M. Hydrogenolysis of glycerol to propylene glycol in continuous system without hydrogen addition over Cu-Ni catalysts. *Appl. Catal. B: Environ.* **2018**, *220*, 31–41. [[CrossRef](#)]
33. Cai, F.; Pan, D.; Ibrahim, J.J.; Zhang, J.; Xiao, G. Hydrogenolysis of glycerol over supported bimetallic Ni/Cu catalysts with and without external hydrogen addition in a fixed-bed flow reactor. *Appl. Catal. A Gen.* **2018**, *564*, 172–182. [[CrossRef](#)]
34. Yu, X.; dos Santos, E.C.; White, J.; Salazar-Alvarez, G.; Pettersson, L.G.M.; Cornell, A.; Johnsson, M. Electrocatalytic Glycerol Oxidation with Concurrent Hydrogen Evolution Utilizing an Efficient MoOx/Pt Catalyst. *Small* **2021**, *17*, 2104288. [[CrossRef](#)]
35. Ripoll, M.; Betancor, L. Opportunities for the valorization of industrial glycerol via biotransformations. *Curr. Opin. Green Sustain. Chem.* **2021**, *28*, 100430. [[CrossRef](#)]
36. Stasiak-Róžańska, L.; Berthold-Pluta, A.; Dikshit, P.K. Valorization of Waste Glycerol to Dihydroxyacetone with Biocatalysts Obtained from *Gluconobacter oxydans*. *Appl. Sci.* **2018**, *8*, 2517. [[CrossRef](#)]
37. Ju, J.-H.; Heo, S.-Y.; Choi, S.-W.; Kim, Y.-M.; Kim, M.-S.; Kim, C.-H.; Oh, B.-R. Effective bioconversion of 1,3-propanediol from biodiesel-derived crude glycerol using organic acid resistance-enhanced *Lactobacillus reuteri* JH83. *Bioresour. Technol.* **2021**, *337*, 125361. [[CrossRef](#)] [[PubMed](#)]
38. Efthymiou, M.-N.; Pateraki, C.; Papapostolou, H.; Lin, C.S.K.; Koutinas, A. Restructuring the sunflower-based biodiesel industry into a circular bio-economy business model converting sunflower meal and crude glycerol into succinic acid and value-added co-products. *Biomass Bioenergy* **2021**, *155*, 106265. [[CrossRef](#)]
39. Haider, M.H.; Dummer, N.F.; Knight, D.W.; Jenkins, R.L.; Howard, M.; Moulijn, J.; Taylor, S.H.; Hutchings, G.J. Efficient green methanol synthesis from glycerol. *Nat. Chem.* **2015**, *7*, 1028–1032. [[CrossRef](#)]
40. Verhelst, S.; Turner, J.W.; Sileghem, L.; Vancoillie, J. Methanol as a fuel for internal combustion engines. *Prog. Energy Combust. Sci.* **2019**, *70*, 43–88. [[CrossRef](#)]
41. Wang, C.; Li, Y.; Xu, C.; Badawy, T.; Sahu, A.; Jiang, C. Methanol as an octane booster for gasoline fuels. *Fuel* **2019**, *248*, 76–84. [[CrossRef](#)]
42. Wang, Y.; Xiao, Y.; Xiao, G. Sustainable value-added C3 chemicals from glycerol transformations: A mini review for heterogeneous catalytic processes. *Chin. J. Chem. Eng.* **2019**, *27*, 1536–1542. [[CrossRef](#)]
43. Kosamia, N.M.; Samavi, M.; Uprety, B.K.; Rakshit, S.K. Valorization of Biodiesel Byproduct Crude Glycerol for the Production of Bioenergy and Biochemicals. *Catalysts* **2020**, *10*, 609. [[CrossRef](#)]
44. Veluturla, S.; Archana, N.; Rao, D.S.; Hezil, N.; Indraj, I.; Spoorthi, S. Catalytic valorization of raw glycerol derived from biodiesel: A review. *Biofuels* **2018**, *9*, 305–314. [[CrossRef](#)]
45. Li, X.-L.; Zhou, Q.; Pan, S.-X.; He, Y.; Chang, F. A Review of Catalytic Upgrading of Biodiesel Waste Glycerol to Valuable Products. *Curr. Green Chem.* **2020**, *7*, 259–266. [[CrossRef](#)]
46. Tabassum, N.; Pothu, R.; Pattnaik, A.; Boddula, R.; Balla, P.; Gundeboyina, R.; Challa, P.; Rajesh, R.; Perugopu, V.; Mamed, N.; et al. Heterogeneous Catalysts for Conversion of Biodiesel-Waste Glycerol into High-Added-Value Chemicals. *Catalysts* **2022**, *12*, 767. [[CrossRef](#)]
47. Liu, X.; Yin, B.; Zhang, W.; Yu, X.; Du, Y.; Zhao, S.; Zhang, G.; Liu, M.; Yan, H.; Abbotsi-Dogbey, M.; et al. Catalytic Transfer Hydrogenolysis of Glycerol over Heterogeneous Catalysts: A Short Review on Mechanistic Studies. *Chem. Rec.* **2021**, *21*, 1792–1810. [[CrossRef](#)] [[PubMed](#)]
48. Minh, A.L.C.; Samudrala, S.P.; Bhattacharya, S. Valorisation of Glycerol through Catalytic Hydrogenolysis Routes for Sustainable Production of Value-Added C3 Chemicals: Current and Future Trends. *Sustain. Energy Fuels* **2022**, *6*, 596–639. [[CrossRef](#)]
49. Fan, L.; Liu, B.; Liu, X.; Senthikumar, N.; Wang, G.; Wen, Z. Recent Progress in Electrocatalytic Glycerol Oxidation. *Energy Technol.* **2021**, *9*, 2000804. [[CrossRef](#)]

50. Moreira, R.; Bimbela, F.; Gandía, L.M.; Ferreira, A.; Sánchez, J.L.; Portugal, A. Oxidative steam reforming of glycerol. A review. *Renew. Sustain. Energy Rev.* **2021**, *148*, 111299. [[CrossRef](#)]
51. Sun, Y.-Q.; Shen, J.-T.; Yan, L.; Zhou, J.-J.; Jiang, L.-L.; Chen, Y.; Yuan, J.-L.; Feng, E.; Xiu, Z.-L. Advances in bioconversion of glycerol to 1,3-propanediol: Prospects and challenges. *Process Biochem.* **2018**, *71*, 134–146. [[CrossRef](#)]
52. Basu, S.; Sen, A.K. A Review on Catalytic Dehydration of Glycerol to Acetol. *ChemBioEng Rev.* **2021**, *8*, 633–653. [[CrossRef](#)]
53. Abdullah, A.; Zuhairi Abdullah, A.; Ahmed, M.; Khan, J.; Shahadat, M.; Umar, K.; Alim, M.A. A review on recent developments and progress in sustainable acrolein production through catalytic dehydration of bio-renewable glycerol. *J. Clean. Prod.* **2022**, *341*, 130876. [[CrossRef](#)]
54. Akbulut, D.; Özkaz, S. A review of the catalytic conversion of glycerol to lactic acid in the presence of aqueous base. *RSC Adv.* **2022**, *12*, 18864–18883. [[CrossRef](#)]
55. Smith, L.R.; Smith, P.J.; Mugford, K.S.; Douthwaite, M.; Dummer, N.F.; Willock, D.J.; Howard, M.; Knight, D.W.; Taylor, S.H.; Hutchings, G.J. New insights for the valorisation of glycerol over MgO catalysts in the gas-phase. *Catal. Sci. Technol.* **2019**, *9*, 1464–1475. [[CrossRef](#)]
56. Sainna, M.A.; Nanavati, S.; Black, C.; Smith, L.R.; Mugford, K.; Jenkins, H.J.; Douthwaite, M.; Dummer, N.F.; Catlow, R.C.A.; Hutchings, G.J.; et al. A combined periodic DFT and QM/MM approach to understand the radical mechanism of the catalytic production of methanol from glycerol. *Faraday Discuss.* **2021**, *229*, 108–130. [[CrossRef](#)] [[PubMed](#)]
57. Smith, P.J.; Smith, L.; Dummer, N.F.; Douthwaite, M.; Willock, D.J.; Howard, M.; Knight, D.W.; Taylor, S.H.; Hutchings, G.J. Investigating the Influence of Reaction Conditions and the Properties of Ceria for the Valorisation of Glycerol. *Energies* **2019**, *12*, 1359. [[CrossRef](#)]
58. Devlia, J.; Smith, L.; Douthwaite, M.; Taylor, S.H.; Willock, D.J.; Hutchings, G.J.; Dummer, N.F. The formation of methanol from glycerol bio-waste over doped ceria-based catalysts. *Philos. Trans. R. Soc. London. Ser. A Math. Phys. Eng. Sci.* **2020**, *378*, 20200059. [[CrossRef](#)] [[PubMed](#)]
59. Smith, L.R.; Sainna, M.A.; Douthwaite, M.; Davies, T.E.; Dummer, N.F.; Willock, D.J.; Knight, D.W.; Catlow, C.R.A.; Taylor, S.H.; Hutchings, G.J. Gas Phase Glycerol Valorization over Ceria Nanostructures with Well-Defined Morphologies. *ACS Catal.* **2021**, *11*, 4893–4907. [[CrossRef](#)] [[PubMed](#)]
60. Mai, H.-X.; Sun, L.-D.; Zhang, Y.-W.; Si, R.; Feng, W.; Zhang, H.-P.; Liu, A.H.-C.; Yan, C.-H. Shape-Selective Synthesis and Oxygen Storage Behavior of Ceria Nanopolyhedra, Nanorods, and Nanocubes. *J. Phys. Chem. B* **2005**, *109*, 24380–24385. [[CrossRef](#)] [[PubMed](#)]
61. Mitran, G.; Neațu, F.; Neațu, Ș.; Trandafir, M.M.; Florea, M. VALPOs as Efficient Catalysts for Glycerol Conversion to Methanol. *Catalysts* **2020**, *10*, 728. [[CrossRef](#)]
62. Joost, G.V.B.; Robertus, H.V.; Hero, J.H. *Biomethanol from Glycerol*; IntechOpen: London, UK, 2012.
63. Van Bennekom, J.; Venderbosch, R.; Assink, D.; Lemmens, K.; Heeres, H. Bench scale demonstration of the Supermethanol concept: The synthesis of methanol from glycerol derived syngas. *Chem. Eng. J.* **2012**, *207–208*, 245–253. [[CrossRef](#)]
64. Kostyniuk, A.; Bajec, D.; Likoza, B. One-step synthesis of ethanol from glycerol in a gas phase packed bed reactor over hierarchical alkali-treated zeolite catalyst materials. *Green Chem.* **2020**, *22*, 753–765. [[CrossRef](#)]
65. Furikado, I.; Miyazawa, T.; Koso, S.; Shimao, A.; Kunimori, K.; Tomishige, K. Catalytic performance of Rh/SiO₂ in glycerol reaction under hydrogen. *Green Chem.* **2007**, *9*, 582–588. [[CrossRef](#)]
66. Miyazawa, T.; Kusunoki, Y.; Kunimori, K.; Tomishige, K. Glycerol conversion in the aqueous solution under hydrogen over Ru/C + an ion-exchange resin and its reaction mechanism. *J. Catal.* **2006**, *240*, 213–221. [[CrossRef](#)]
67. Ruy, A.D.D.S.; Alves, R.M.D.B.; Hewer, T.L.R.; Pontes, D.D.A.; Teixeira, L.S.G.; Pontes, L.A.M. Catalysts for glycerol hydrogenolysis to 1,3-propanediol: A review of chemical routes and market. *Catal. Today* **2021**, *381*, 243–253. [[CrossRef](#)]
68. Zhao, H.; Zheng, L.; Li, X.; Chen, P.; Hou, Z. Hydrogenolysis of glycerol to 1,2-propanediol over Cu-based catalysts: A short review. *Catal. Today* **2019**, *355*, 84–95. [[CrossRef](#)]
69. Hu, Y.; He, Q.; Xu, C. Catalytic Conversion of Glycerol into Hydrogen and Value-Added Chemicals: Recent Research Advances. *Catalysts* **2021**, *11*, 1455. [[CrossRef](#)]
70. van Ryneveld, E.; Mahomed, A.S.; van Heerden, P.S.; Green, M.J.; Friedrich, H.B. A catalytic route to lower alcohols from glycerol using Ni-supported catalysts. *Green Chem.* **2011**, *13*, 1819–1827. [[CrossRef](#)]
71. Shoji, M.L.; Dasireddy, V.D.B.C.; Singh, S.; Mohlala, P.; Morgan, D.J.; Friedrich, H.B. Hydrogenolysis of Glycerol to Monoalcohols over Supported Mo and W Catalysts. *ACS Sustain. Chem. Eng.* **2016**, *4*, 5752–5760. [[CrossRef](#)]
72. Shoji, M.L.; Dasireddy, V.D.B.C.; Singh, S.; Govender, A.; Mohlala, P.; Friedrich, H.B. The effect of rhenium on the conversion of glycerol to mono-alcohols over nickel catalysts under continuous flow conditions. *Sustain. Energy Fuels* **2019**, *3*, 2038–2047. [[CrossRef](#)]
73. Gatti, M.N.; Cerioni, J.L.; Pompeo, F.; Santori, G.F.; Nichio, N.N. High Yield to 1-Propanol from Crude Glycerol Using Two Reaction Steps with Ni Catalysts. *Catalysts* **2020**, *10*, 615. [[CrossRef](#)]
74. Hu, S.; Luo, X.; Wan, C.; Li, Y. Characterization of crude glycerol from biodiesel plants. *J. Agric. Food Chem.* **2012**, *60*, 5915–5921. [[CrossRef](#)]
75. Kumar, L.R.; Yellapu, S.K.; Tyagi, R.; Zhang, X. A review on variation in crude glycerol composition, bio-valorization of crude and purified glycerol as carbon source for lipid production. *Bioresour. Technol.* **2019**, *293*, 122155. [[CrossRef](#)]

76. Luo, X.; Ge, X.; Cui, S.; Li, Y. Value-added processing of crude glycerol into chemicals and polymers. *Bioresour. Technol.* **2016**, *215*, 144–154. [[CrossRef](#)] [[PubMed](#)]
77. Bartholomew, C.H. Mechanisms of catalyst deactivation. *Appl. Catal. A Gen.* **2001**, *212*, 17–60. [[CrossRef](#)]
78. Ardi, M.; Aroua, M.; Hashim, N.A. Progress, prospect and challenges in glycerol purification process: A review. *Renew. Sustain. Energy Rev.* **2015**, *42*, 1164–1173. [[CrossRef](#)]
79. Kong, P.S.; Aroua, M.K.; Daud, W.M.A.W. Conversion of crude and pure glycerol into derivatives: A feasibility evaluation. *Renew. Sustain. Energy Rev.* **2016**, *63*, 533–555. [[CrossRef](#)]
80. López, A.; Aragón, J.; Hernández-Cortez, J.; Mosqueira, M.; Martínez-Palou, R. Study of hydrotalcite-supported transition metals as catalysts for crude glycerol hydrogenolysis. *Mol. Catal.* **2019**, *468*, 9–18. [[CrossRef](#)]
81. Nanda, M.R.; Yuan, Z.; Shui, H.; Xu, C. (Selective Hydrogenolysis of Glycerol and Crude Glycerol (a By-Product or Waste Stream from the Biodiesel Industry) to 1,2-Propanediol over B₂O₃ Promoted Cu/Al₂O₃ Catalysts. *Catalysts* **2017**, *7*, 196. [[CrossRef](#)]
82. Wu, Z.; Yan, H.; Ge, S.; Gao, J.; Dou, T.; Li, Y.; Yip, A.C.; Zhang, M. MoO₃ modified Ni₂P/Al₂O₃ as an efficient catalyst for crude glycerol to propylene. *Catal. Commun.* **2017**, *92*, 80–85. [[CrossRef](#)]
83. Tao, M.; Li, Y.; Li, Y.; Zhang, X.; Geletii, Y.V.; Wang, X.; Hill, C.L. Heterogenization of polyoxometalates as solid catalysts in aerobic oxidation of glycerol. *Catal. Sci. Technol.* **2020**, *10*, 3771–3781. [[CrossRef](#)]
84. Arcanjo, M.R.A.; Paniagua, M.; Morales, G.A.; Iglesias, J.; Melero, J.A.; Da Silva, I.; Rodríguez-Castellón, E.; Vieira, R.S. Temperature Effect on Pretreatment of the Activated Carbon Support (Pt/AC and Pd/AC) for Glycerin into Lactic Acid. *Ind. Eng. Chem. Res.* **2020**, *59*, 14643–14657. [[CrossRef](#)]
85. Vankudoth, K.; Gutta, N.; Velisoju, V.K.; Mutyala, S.; Aytam, H.P.; Akula, V. CuCr₂O₄ derived by the sol–gel method as a highly active and selective catalyst for the conversion of glycerol to 2,6-dimethylpyrazine: A benign and eco-friendly process. *Catal. Sci. Technol.* **2017**, *7*, 3399–3407. [[CrossRef](#)]
86. Vankudoth, K.; Velisoju, V.K.; Gutta, N.; Sathu, N.K.; Aytam, H.P.; Inkollu, S.; Akula, V. Zn-Modified CuCr₂O₄ as Stable and Active Catalyst for the Synthesis of 2,6-Dimethylpyrazine: Valorization of Crude Glycerol Obtained from a Biodiesel Plant. *Ind. Eng. Chem. Res.* **2017**, *56*, 11664–11671. [[CrossRef](#)]
87. Wang, Y.; Furukawa, S.; Song, S.; He, Q.; Asakura, H.; Yan, N. Catalytic Production of Alanine from Waste Glycerol. *Angew. Chem. Int. Ed.* **2020**, *59*, 2289–2293. [[CrossRef](#)] [[PubMed](#)]
88. Chiosso, M.E.; Casella, M.L.; Merlo, A.B. Synthesis and catalytic evaluation of acidic carbons in the etherification of glycerol obtained from biodiesel production. *Catal. Today* **2021**, *372*, 107–114. [[CrossRef](#)]
89. Lu, Q.; Liu, R.; Xia, G. Sequential Dehydration and Oxidation of Biodiesel-derived Crude Glycerol into Acrylic Acid. *Russ. J. Appl. Chem.* **2018**, *91*, 235–244. [[CrossRef](#)]
90. Talebian-Kiakalaieh, A.; Tarighi, S. Hierarchical faujasite zeolite-supported heteropoly acid catalyst for acetalization of crude-glycerol to fuel additives. *J. Ind. Eng. Chem.* **2019**, *79*, 452–464. [[CrossRef](#)]
91. Veiga, S.; Bussi, J. Steam reforming of crude glycerol over nickel supported on activated carbon. *Energy Convers. Manag.* **2017**, *141*, 79–84. [[CrossRef](#)]
92. He, S.; Muizebelt, I.; Heeres, A.; Schenk, N.J.; Bles, R.; Heeres, H.J. Catalytic pyrolysis of crude glycerol over shaped ZSM-5/bentonite catalysts for bio-BTX synthesis. *Appl. Catal. B Environ.* **2018**, *235*, 45–55. [[CrossRef](#)]
93. Singh, V.; Arumugam, S.; Tathod, A.P.; Viswanadham, N. Efficient Bifunctional Catalysts for Enhanced Carbon Conversions and Alky-Aromatics Production in Crude Bio-glycerol Methanol Processes. *ACS Sustain. Chem. Eng.* **2022**, *10*, 5323–5332. [[CrossRef](#)]
94. Finn, M.; Ridenour, J.A.; Heltzel, J.; Cahill, C.; Voutchkova-Kostal, A. Next-Generation Water-Soluble Homogeneous Catalysts for Conversion of Glycerol to Lactic Acid. *Organometallics* **2018**, *37*, 1400–1409. [[CrossRef](#)]
95. Okoye, P.; Abdullah, A.; Hameed, B. Synthesis of oxygenated fuel additives via glycerol esterification with acetic acid over bio-derived carbon catalyst. *Fuel* **2017**, *209*, 538–544. [[CrossRef](#)]
96. Bedogni, G.; Acevedo, M.D.; Aguzín, F.; Okulik, N.B.; Padró, C.L. Synthesis of bioadditives of fuels from biodiesel-derived glycerol by esterification with acetic acid on solid catalysts. *Environ. Technol.* **2018**, *39*, 1955–1966. [[CrossRef](#)] [[PubMed](#)]
97. Saini, B.; Tathod, A.P.; Saxena, S.K.; Arumugam, S.; Viswanadham, N. Sustainable Upgrade of Bioderived Glycerol to Solketal through Acetalization over Metal-Free Mordenite Catalysts. *ACS Sustain. Chem. Eng.* **2022**, *10*, 1172–1181. [[CrossRef](#)]