

# Case Study of Anaerobic Digestion Process Stability Detected by Dissolved Hydrogen Concentration

## Authors:

Daniela Platošová, Jiří Rusín, Jan Platoš, Kateřina Smutná, Roman Buryjan

Date Submitted: 2022-01-24

Keywords: anaerobic digestion, Fermentation, rotary bioreactor, dissolved hydrogen, amperometric sensor

## Abstract:

The paper presents the results of a laboratory experiment of mesophilic single-stage anaerobic digestion performed to verify the possibility of early detection of process instability and reactor overload by evaluating the course of dissolved hydrogen concentration of the main intermediate. The digestion process was run in a Terrafors IS rotary drum bioreactor for 230 days. The substrate dosed on weekdays was food leftovers from the university canteen. At an average temperature of 37 °C, an organic loading of volatiles of 0.858 kg m<sup>-3</sup> day<sup>-1</sup> and a theoretical retention time of 259 days, biogas production of 0.617 Nm<sup>3</sup> kg VS<sup>-1</sup> was achieved with a CH<sub>4</sub> content of 51.7 vol. %. The values of the established FOS/TAC stability indicator ranged from 0.26 to 11.4. The highest value was reached when the reactor was overloaded. The dissolved hydrogen concentration measured by the amperometric microsensor ranged from 0.039 to 0.425 mg dm<sup>-3</sup>. Data were statistically processed using Pearson's correlation coefficient. The correlation of the hydrogen concentration with other parameters such as the concentration of organic acids was evaluated. The value of Pearson's correlation coefficient was 0.331 and corresponded to a p-value of 0. The results confirmed a very low limit of the hydrogen concentration at which the microbial culture, especially methanogens, was already overloaded. The amperometric microsensor proved to be rather unsuitable for operational applications due to insufficient sensitivity and short service life. The newly designed ratio of dissolved hydrogen concentration to neutralizing capacity was tested but did not work significantly better than the established FOS/TAC stability indicator.

Record Type: Published Article

Submitted To: LAPSE (Living Archive for Process Systems Engineering)

Citation (overall record, always the latest version):

LAPSE:2022.0013

Citation (this specific file, latest version):

LAPSE:2022.0013-1

Citation (this specific file, this version):

LAPSE:2022.0013-1v1

DOI of Published Version: <https://doi.org/10.3390/pr9010106>

License: Creative Commons Attribution 4.0 International (CC BY 4.0)

## Article

# Case Study of Anaerobic Digestion Process Stability Detected by Dissolved Hydrogen Concentration

Daniela Platošová <sup>1,\*</sup> , Jiří Rusín <sup>1</sup>, Jan Platoš <sup>2</sup> , Kateřina Smutná <sup>3</sup> and Roman Buryjan <sup>4</sup>

<sup>1</sup> Institute of Environmental Technology, VSB—Technical University of Ostrava, 17. Listopadu 2172/15, 70800 Ostrava, Czech Republic; jiri.rusin@vsb.cz

<sup>2</sup> Department of Computer Science, Faculty of Electrical Engineering and Computer Science, VSB—Technical University of Ostrava, 17. Listopadu 2172/15, 70800 Ostrava, Czech Republic; jan.platos@vsb.cz

<sup>3</sup> Institute of Languages, VSB—Technical University of Ostrava, 17. Listopadu 2172/15, 70800 Ostrava, Czech Republic; katerina.smutna1@vsb.cz

<sup>4</sup> GAS Control s.r.o, Nový Svět 1407/59a, 73564 Havířov-Prostřední Suchá, Czech Republic; buryjan@gascontrol.cz

\* Correspondence: daniela.platosova@vsb.cz

**Abstract:** The paper presents the results of a laboratory experiment of mesophilic single-stage anaerobic digestion performed to verify the possibility of early detection of process instability and reactor overload by evaluating the course of dissolved hydrogen concentration of the main intermediate. The digestion process was run in a Terrafor IS rotary drum bioreactor for 230 days. The substrate dosed on weekdays was food leftovers from the university canteen. At an average temperature of 37 °C, an organic loading of volatiles of 0.858 kg m<sup>-3</sup> day<sup>-1</sup> and a theoretical retention time of 259 days, biogas production of 0.617 Nm<sup>3</sup> kg VS<sup>-1</sup> was achieved with a CH<sub>4</sub> content of 51.7 vol. %. The values of the established FOS/TAC stability indicator ranged from 0.26 to 11.4. The highest value was reached when the reactor was overloaded. The dissolved hydrogen concentration measured by the amperometric microsensor ranged from 0.039–0.425 mg dm<sup>-3</sup>. Data were statistically processed using Pearson's correlation coefficient. The correlation of the hydrogen concentration with other parameters such as the concentration of organic acids was evaluated. The value of Pearson's correlation coefficient was 0.331 and corresponded to a *p*-value of 0. The results confirmed a very low limit of the hydrogen concentration at which the microbial culture, especially methanogens, was already overloaded. The amperometric microsensor proved to be rather unsuitable for operational applications due to insufficient sensitivity and short service life. The newly designed ratio of dissolved hydrogen concentration to neutralizing capacity was tested but did not work significantly better than the established FOS/TAC stability indicator.

**Keywords:** anaerobic digestion; fermentation; rotary bioreactor; dissolved hydrogen; amperometric sensor



**Citation:** Platošová, D.; Rusín, J.; Platoš, J.; Smutná, K.; Buryjan, R. Case Study of Anaerobic Digestion Process Stability Detected by Dissolved Hydrogen Concentration. *Processes* **2021**, *9*, 106. <https://doi.org/10.3390/pr9010106>

Received: 11 November 2020

Accepted: 5 January 2021

Published: 7 January 2021

**Publisher's Note:** MDPI stays neutral with regard to jurisdictional claims in published maps and institutional affiliations.



**Copyright:** © 2021 by the authors. Licensee MDPI, Basel, Switzerland. This article is an open access article distributed under the terms and conditions of the Creative Commons Attribution (CC BY) license (<https://creativecommons.org/licenses/by/4.0/>).

## 1. Introduction

Controlled anaerobic digestion with biogas production is an established and, in the future, promising way of ecological use of biomass and renewable energy production. The technology of biogas plants is based on the biological decomposition of organic substances in an environment without access to air. This is a bioenergetic transformation of substances in which there is no significant reduction in a fertilizer value. The products are a biologically stabilized material called digestate, which is used mainly as a fertilizer and biogas with a methane content of 55–70% and a calorific value of about 18–26 MJ Nm<sup>-3</sup>.

Anaerobic digestion is a complex biochemical process that consists of many parts, consecutive and parallel processes; Gujer and Zehnder illustrate this in a diagram [1]. To simplify the explanation, most authors divide the process into four primary phases [2]: hydrolysis is the first stage of decomposition; macromolecular organic substances are broken

down into low molecular weight water-soluble substances. Decomposition takes place using extracellular hydrolytic enzymes, which are produced exclusively by fermentation bacteria. In the second phase, acidogenesis, the products of hydrolysis decompose into simpler organic substances, such as alcohols, acids, CO<sub>2</sub>, and hydrogen, mainly by the action of bacteria. The third phase is acetogenesis, the formation of acetic acid. Syntrophic acetogenic microorganisms decompose organic acids higher than acetic acid, alcohols, and aromatic compounds. CO<sub>2</sub> and H<sub>2</sub> are also produced. The last phase is methanogenesis. Commonly, predominantly acetotrophic methanogenic microorganisms decompose the acetic anion to form methane and CO<sub>2</sub>. Hydrogenotrophic methanogens consume H<sub>2</sub> and CO<sub>2</sub> to produce methane. CH<sub>4</sub> and CO<sub>2</sub> predominate in biogas from balanced digestion in a ratio corresponding mainly to the composition of the incoming organic matter in the substrate [3]. The interaction of many groups of microorganisms is essential for the long-term maintenance of the conditions of efficient conversion of organic matter. Excess hydrogen in the whole system inhibits the activity of methanogens, as well as acetogenesis, and can cause chaining problems leading to the collapse of the whole process. The conditions in the fermenter of the biogas plant with regard to the one-stage process are maintained by the operator so that said digestion phases are in equilibrium for a long time. If there is a more significant imbalance, restoring equilibrium may not be easy at all for a short period.

### 1.1. Variables Monitored during the Digestion Process

If we consider a mature biogas technology ensuring minimal temperature fluctuations and minimal air supply to the fermenter, the following variables are monitored for continuous evaluation of process stability: biogas production is still sometimes the only monitored parameter. It does not describe the state of the process but only its result, which depends on the amount of organic substances introduced and on a high number of other factors. The concentration of CH<sub>4</sub> in biogas is also not the main indicator of process stability. It is rather a balance element. The amount of CH<sub>4</sub> produced must be in relation to the organic load applied or to loads of the main groups of substrates, such as fats versus carbohydrates versus proteins. A more sensitive indicator of process stability is the CH<sub>4</sub>/CO<sub>2</sub> concentration ratio. This ratio is determined by the composition of the feed mixture and does not change much during the stable operation of the fermenter. The hydrogen concentration in biogas is one of the more sensitive indicators of process stability. In general, it can be stated that the appearance of H<sub>2</sub> in biogas almost always signals the instability of the process. However, it is almost impossible to achieve an equilibrium distribution of H<sub>2</sub> between the liquid and gas phases, which makes the evaluation of this parameter difficult. pH is not a sufficiently sensitive indicator of process stability. If the pH drops, this indicates dosing errors made in the last few days to weeks. It is necessary to monitor the pH, especially when digesting substrates that do not provide sufficient neutralizing capacity of the suspension in the fermenter or substrates that are too nitrogenous. The neutralization capacity (buffering capacity) of the reactor consists mainly of the equilibrium system HCO<sub>3</sub><sup>-</sup>/CO<sub>2</sub> together with the equilibrium system NH<sub>4</sub><sup>+</sup>/NH<sub>3</sub>. Adequately high neutralization capacity is the most important factor or prerequisite for maintaining the stability of the process at high organic loading. The content of lower (volatile) fatty acids (VFA) is one of the most sensitive indicators of stability. Usually, the sum of C<sub>2</sub>–C<sub>5</sub> acids is monitored, but it is more appropriate to monitor individual acids. Even a relatively high concentration of acetic acid can be removed quickly, but higher acids usually paralyze the system for a longer time [4]. The VFA/TIC (Total Inorganic Carbonate) parameter is the ratio of the sum of lower fatty acids expressed by the equivalent of acetic acid and the neutralizing capacity formed mainly by the bicarbonate system. The titration parameter detects a possible buffer deficiency and an excess of acids. It has become the most valuable indicator of process stability, not only at the start of the use of the technology but also continuously [5]. Méndez-Acosta et al. [6] used a Luenberger observer to increase digestion stability by monitoring volatile fatty acid (VFA) and total alkalinity (TA) concentrations in a multiple-input, multiple-output feedback control model. Feitkenhauer et al. [7] confirmed

that online volatile fatty acid (VFA) titration is a reliable method for measuring substrate concentration without the use of expensive analytical equipment. They designed a reliable measuring cell for online titration of volatile fatty acids. Recalibration of the pH probe resistant to high salt concentrations was only necessary twice a week. Yuan and Zhu [8] studied a variety of inhibitory substances and found that intermediate products are the primary cause of anaerobic digester upset or failure, including free ammonia (FA), volatile fatty acids (VFAs), and sulfide/sulfate. However, they are essential nutrients for bacterial growth and the anaerobic digestion process.

### 1.2. Sensors and the Measurement of the Parameters

Many other parameters can be monitored, but they usually encounter a more complicated treatment of the sludge sample before analysis. The results for evaluation are available with an impractically long time delay. It is advisable to continue looking for an easily measurable and informative parameter, according to which it would be possible to react immediately to the emerging imbalance in the fermenter. The process biochemistry suggests the possibility of rapid capture of changes by monitoring the dissolved hydrogen concentration parameter. According to research in the field of wastewater treatment and from research on fermenters of biogas plants, the anaerobic process can be controlled in connection with the measurement of the concentration of the most important chemical intermediate—dissolved diatomic hydrogen  $H_2(l)$ . The literature gives several lab-scale or pilot-scale examples, each using a different type of  $H_2(l)$  sensor.  $H_2(l)$  most rapidly detects the upcoming overload of the slowest growing-methanogenic microbial biomass. Dohányos states that the fastest detection of overload can be performed by measuring  $H_2(l)$  in the range of 0–200  $mmol\ m^{-3}$ , which corresponds to a partial equilibrium pressure of  $H_2$  up to 20,000 Pa [9]. Cord-Ruwisch et al. verified that the partial pressure of dissolved  $H_2$  in the range of 2–8 Pa correlates linearly with the overload, and the normal limit of stability is not higher than 5–6 Pa. [10]. Paus et al. indicate the common  $H_2(l)$  concentration of 2–3.5  $\mu mol\ dm^3$  correlating to 200–350 Pa [11]. Srinivasan recommends in situ online measuring of the concentration of dissolved  $H_2$  with a Clark oxygen probe with reversed polarization and a more powerful electrical signal amplifier. It is a polarized platinum electrode, and the  $H_2(l)$  sensitivity should be linear between 1–50  $\mu M$  corresponding to 100–5000 Pa [12]. The long-term stability of the probe and  $H_2S$  interference does not appear to be known [13]. Alternatively, dissolved hydrogen can be entrained in the carrier gas, and the mixture continuously analyzed chromatographically, but this is not a suitable operating method for biogas plant operators [12]. Archer et al. verified the applicability of the Exhaled Hydrogen Monitor EHM (Gas Measurement Instruments Ltd., Renfrew, Scotland) in a biogas plant using a 6  $m^3$  fermenter. The EHM can measure gaseous hydrogen in biogas exactly up to the limit of 0.1 Pa even in industrial conditions. The results had to be corrected according to the  $H_2S$ ,  $CH_4$ , and  $CO_2$  cross-sensitivities. Hydrogen peaks in biogas occurred 3–6 h after shock overload. The results showed that it would be more appropriate to measure hydrogen in the liquid phase [14]. Strong et al. described the construction and use of a cheap sensor, unfortunately with insufficient sensitivity at the level of 30 Pa [15]. Darnetun et al. developed a sensitive palladium metal-oxide-semiconductor (Pd-MOS)  $H_2$  gas sensor with a detection limit of 0.1 Pa [16]. Apparently, this sensor has not yet been tested for anaerobic digestion. Only a few biogas plants exist, which rely solely on  $H_2$  measurements for stability monitoring. If hydrogen is monitored at biogas plants, it is measured by electrochemical sensors in the biogas. In the future, the measurements of dissolved  $H_2$  could become an interesting alternative [17]. Wilcox et al. [18] tested an online bicarbonate alkalinity (BA) sensor and recognized disturbances by a neural network. They concluded that the system is practically usable and useful in the case of an inlet with insufficient buffering capacity. The authors [19] hypothesize that an imbalance in the AD process can lead to the accumulation of short-chain organic acids, as high concentrations of these acids inhibit methane formation and, in extreme cases, this can lead to the death of the corresponding bacterial populations. They are based on the assumption that there

is an analogy between the flora of microorganisms in the rumen of a ruminant and the fermenter reactor of a biogas plant. In a healthy animal, the pan-flora is predominantly Gram-negative and has various forms. In the case of malnutrition, this diversity decreases, and Gram-positive lactic acid-producing streptococci soon prevail and lactobacilli will predominate. This condition is known as rumen acidosis. According to the patent, an analogous change of the bacterial population from Gram-negative to Gram-positive in the fermenter is used as an indicator of process interruption in a biogas plant. Bacterial detection was performed by FT-MIR spectrometry.

Nguyen et al. [20] studied two significant strategies to promote the stable performance of the AD process, including monitoring and control over the process. While there is a constant debate on the importance of instrumentation versus control strategy, the experience on both aspects is limited in industrial-scale AD operations. With the rapid development of instrumentation and automatic control, the implementation and operation cost of this advanced system is expected to decrease. The optimistic outlook for the upcoming decades is that small-scale AD plants will be equipped with an automatic control system for better performance. Meanwhile, a centralized AD plant is still a feasible option. Liu et al. [21] introduced a new control strategy for operating anaerobic digestion processes efficiently at high load. The control system includes a cascade controller embedded into a rule-based supervisory system based on extremum-seeking control. The control system measures pH and biogas production rate and varies the organic load by manipulating the influent flow. Good control performances were achieved during the start-up and steady-state running operations and during the rejection of disturbances. The control system can run the process under a high load condition and efficiently reject disturbances without explicit measurement of the influent characteristics (Gaida et al. [22]). Over the last 40 years, many different control methodologies for substrate feed control of anaerobic digestion processes have been proposed in order to increase plant efficiency and sustainable long-term energy production. This review shows that although sophisticated controllers exist, full-scale biogas plants are mostly still operated without a closed-loop feed control. No matter which application, such control always has to find a compromise between maximizing economic yield, minimizing the ecological footprint, and minimizing the risk of process failure. For anaerobic wastewater treatment, control systems that come close to this ideal exist, but for agricultural as well as industrial biogas plants, such control has not yet been developed, and neither has been successfully implemented and validated at full-scale. The main challenges are a lack of robust and reliable process monitoring using online instrumentation and a conservative industry that is reluctant to implement fully automated process control strategies.

Our work aimed to verify the possibility of early detection of digestion process instability and reactor overload by evaluating the course of dissolved hydrogen concentration using an amperometric microsensor.

## 2. Laboratory Testing

Testing took place in the Institute of Environmental Technologies at VSB—Technical University Ostrava, Czech Republic. One 230-day single-stage mesophilic mono-digestion experiment was performed. The process was conducted in a Terrafors IS rotary drum bioreactor (INFORS HT, Bottmingen, Switzerland); see the apparatus diagram in Figure 1. The drum reactor with a total volume of 0.0187 m<sup>3</sup> was filled with 15.0 kg (approximately 0.015 m<sup>3</sup>) of liquid inoculum, anaerobic slurry, from the lab-scale (0.2 m<sup>3</sup>) psychrophilic reactor processing food leftovers from university canteen at psychrophilic conditions (18–22 °C). The inoculum was freed of particles larger than 5 mm to reduce the formation of floating crusts. During the experiment, the slurry was continuously stirred. The stirring was secured by rotation of the reactor drum around the horizontal axis. The rotation speed was set to 0.5 min<sup>-1</sup>. Digestion temperature was set to 37 °C ± 1 °C. The main parameters of the inoculum are listed in Table 1.

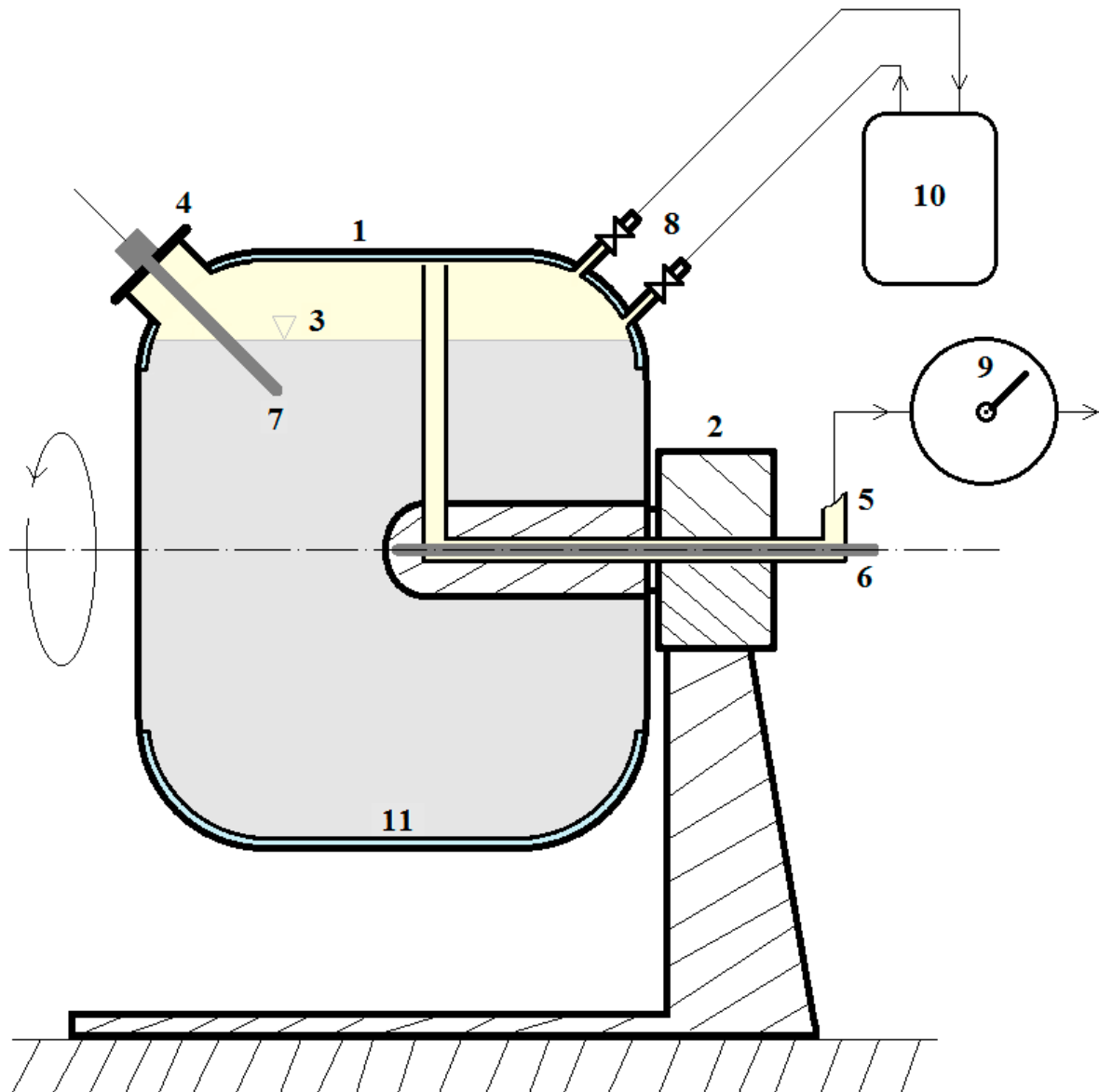

**Figure 1.** Apparatus diagram. 1. Rotary drum reactor. 2. Stator connected to the base. 3. Liquid batch level. 4. Port for substrate dosing and digestate sampling. 5. Biogas outlet tube. 6. Thermocouple. 7. Dissolved hydrogen sensor. 8. Two valves for sampling and return of biogas. 9. Gas flow meter. 10. Portable gas analyzer. 11. Water heated jacket.

**Table 1.** Inoculum, Substrate, and Digestate Parameters.

Parameter	Symbol, Unit	Inoculum	Substrate	Digestate
Potential of Hydrogen	pH-H <sub>2</sub> O, -	7.63	3.4–5.6; mean 4.2	3.4–7.9, mean 7.1
Total Solids (105 °C)	TS, wt. %	2.96	11.2–24.9; mean 16.4	2.2–5.4; mean 3.6
Volatile Solids (550 °C)	VS, wt. % <sub>TS</sub>	59.79	86.00–96.10; mean 92.90	50.00–70.60; mean 61.30
Volatile Fatty Acids	VFA, mg dm <sup>-3</sup>	3050	-	1999–15,856; mean 5352
Total Inorganic Carbonate	TIC, mg dm <sup>-3</sup>	13,650	-	1226–14,489; mean 9773
Digestion Stability Ratio	VFA/TIC, -	0.223	-	0.161–11.431; mean 1.323

Food leftovers of meals served in the university canteen were used as complex mono-substrate. Those leftovers were not like common kitchen biowaste. It consisted of uneaten portions of lunches, without bones. The substrate obtained from the canteen was sup-

plemented with a small amount of drinking water to decrease the content of solids to a pumpable level. Subsequently, the mixture was homogenized with TS-32T400V screw mill (RM Gastro Ltd., Prague, Czech Republic) through a matrix with round holes (3 mm in diameter). The substrate slurry was stored in a refrigerator at 4–6 °C to suppress acidification. The substrate was dosed into the drum reactor once every working day. The experiment lasted for 230 days, so we dosed the reactor 165 times. The average dose was about 80 g of the substrate. The regular size was 50 g, but for the overloading, we used a much larger amount—up to 300 g. The main parameters of the substrate are listed in Table 1.

The slurry temperature was continuously measured by a thermocouple passing through the horizontal shaft of the reactor in the center of the reactor. Data were manually recorded once daily. The biogas stream from the reactor passed through a tube passing from the gas space axially through the horizontal shaft of the reactor. Biogas production was continuously measured with a TG05 rotary drum gas meter (RITTER GmbH, Schwabmünchen, Germany). Gas volume increments were manually recorded once daily. The biogas composition was measured with a Biogas5000 portable analyzer (GEOTECH Ltd., Coventry, Great Britain) once a day in working days, prior to digestate sampling and substrate dosing. The analyzer used CH<sub>4</sub> and CO<sub>2</sub> infrared sensors and O<sub>2</sub> and H<sub>2</sub>S electrochemical sensors. During the gas composition measurements, the reactor rotation was stopped. The biogas sample was sucked through one valve and returned to the gas space of the reactor by an adjacent valve. Immediately after the analysis of the biogas composition, a dissolved hydrogen sensor was inserted into the liquid phase. A valve (32 mm diameter), commonly used for digestate sampling and substrate dosing, was used to insert the H<sub>2</sub> sensor. The sensor was sealed with silicone rubber. It usually took 15 min to stabilize the sensor in the anaerobic slurry. The rotation of the reactor was resumed only after removing the sensor and inserting a dose of the substrate.

The dissolved hydrogen sensor was the MS 08 amperometric microsensor (AMT Analysenmesstechnik GmbH, Rostock, Germany) with a stated detection limit of 0.2 µg dm<sup>-3</sup> H<sub>2</sub>(l) and a range of up to 1.5 mg dm<sup>-3</sup> H<sub>2</sub>(l); see Figure 2. The H<sub>2</sub> sensor used its own separate temperature sensor. The tips of both sensors were always placed approximately 30 mm below the surface of the slurry. After measuring H<sub>2</sub>(l), a digestate sample (approximately 0.9× the volume of the substrate dose) was drained for analysis, and a dose of the substrate was introduced into the reactor. Thus, the digestate sampling was performed at the same frequency as the substrate sampling.



**Figure 2.** Amperometric microsensor and its location in the reactor.

The following analyses were regularly performed on substrate and digestate samples: the determination of pH with a 340i meter a SenTix 41 probe (WTW, Weilheim,

Germany) [23], the determination of total solids (TS, drying at 105 °C in an O<sub>2</sub> atmosphere to constant weight, 2.0% RSD) by a DLB 160 3A moisture analyzer with a halogen lamp (KERN, Balingen, Germany) [24], the determination of the content of organic substances, namely loss on ignition (Volatile Solids, VS, igniting at 550 °C in an O<sub>2</sub> atmosphere to constant weight, 5.0% RSD) by thermogravimetric analyzer TGA 701 (LECO, Benton Harbor, MI, USA) [25]. The VFA/TIC ratio in the digestate slurry was determined by a TIM BIOGAS V02.2 automatic titrator (HACH Lange, Düsseldorf, Germany) [26].

### 3. Results and Discussion

During the 230 days of mono-digestion, the TS content of the substrate was most often around 16%, with a loss on ignition of about 93% TS. The organic loading rate (OLR) was purposefully changed so that there was a significant overload with the evolution of hydrogen and subsequent recovery. Calculated for all 230 days of the experiment, the OLR was varied in the range of 0–3.02 kg<sub>VS</sub> m<sup>-3</sup> d<sup>-1</sup>, with a mean of 0.858 kg<sub>VS</sub> m<sup>-3</sup> day<sup>-1</sup>. Calculated just for the days of feeding, the mean OLR was 1.396 kg<sub>VS</sub> m<sup>-3</sup> d<sup>-1</sup>, which is still a rather low load for the mesophilic reactor. The mean value of hydraulic retention time (HRT) was 259 days. The relation between OLR and HRT is visible in Figure 3. Due to the easy overload, it would be possible to consider shortening the HRT only when co-fermenting the substrate in a more nutritionally balanced mixture.



**Figure 3.** Relation between organic loading and retention time.

The normalized biogas production from inoculum was high due to the transition from psychrophilic to mesophilic process, but within 3 days it dropped rapidly. This was followed by a period of gradual acclimatization and an increase in gas production until day 107. The most efficient process took place at a load of about 2.5 kg<sub>VS</sub> m<sup>-3</sup> d<sup>-1</sup> and an HRT of 65 days. Until day 123, the CH<sub>4</sub> content remained high, but gas production was already declining due to overload. It was not until around day 170 that the process stabilized again due to the omission of substrate doses and, subsequently, only low loading (see Figure 4). Shortly after rebalancing, CH<sub>4</sub> production was unusually high, which is expected due to the methanation of accumulated volatile acids.

The main parameters of the digestate are listed in Table 1. From Figure 5, it is clear that the pH value in the reactor decreased much later than when overloading started, and VFA accumulation started, which is also well-known information. The VFA/TIC limit value determining stability for a given process appears to be approximately 0.4. It is therefore in line with the commonly stated range [26].

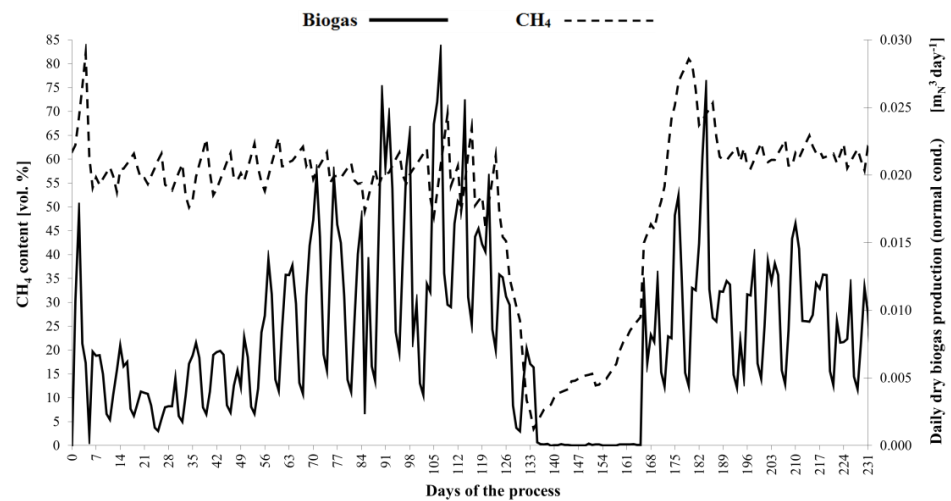

Figure 4. Biogas production and its CH<sub>4</sub> content.

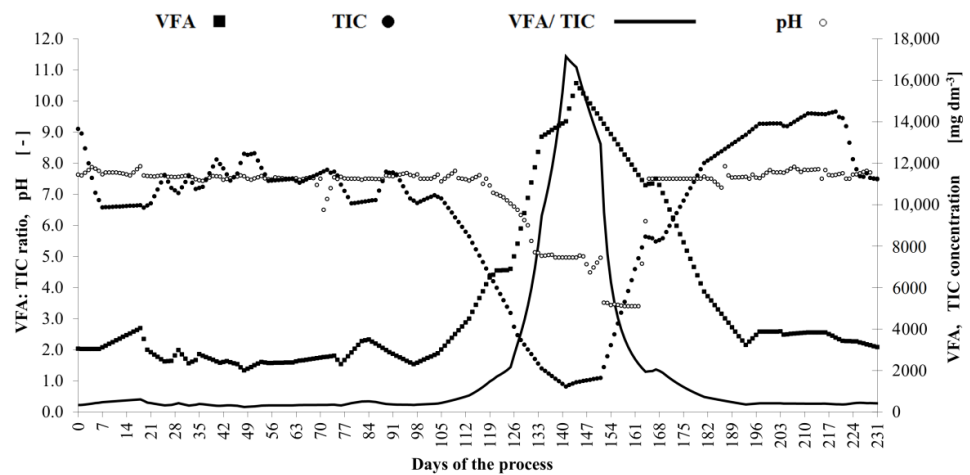

Figure 5. VFA and TIC versus pH.

Thanks to a significant reduction in dosing, the extreme overload (VFA/TIC peak of 11.4) was overcome in about 55 days. The course of the dissolved hydrogen concentration is shown in Figure 6. The dissolved hydrogen concentration measured by the amperometric microsensor ranged from  $0.039 \text{ mg dm}^{-3}$  to  $0.425 \text{ mg dm}^{-3}$ . Apart from overload, the typical  $\text{H}_2(\text{l})$  concentration was  $0.12 \pm 0.04 \text{ mg dm}^{-3}$ , corresponding to about 6000 Pa partial pressure. When overloaded, it reached  $0.40 \text{ mg dm}^{-3} \text{ H}_2(\text{l})$ , corresponding to about 20,000 Pa partial pressure. Similarly, high values were measured even after the initial heating of the inoculum at the beginning of the experiment. If the increased hydrogen persisted for several days, the acid content increased rapidly. The maximum  $\text{H}_2(\text{l})$  concentration measured by us therefore approximately corresponds to the value given by Dohányos [6]. The small peak of the  $\text{H}_2(\text{l})$  that appears around day 105 was caused by the four days of reactor starvation due to Easter break followed by the high doses of substrate.

An alternative process stability parameter was proposed as the ratio of dissolved hydrogen concentration to neutralization capacity; see Figure 7. However, so far, this parameter does not appear to be significantly more sensitive than the VFA/TIC ratio used. After the height correction of the peaks, the front of both peaks is situated on the same days of the process. It will be necessary to test this behavior in several different co-fermentation processes. In the case of the process monitored here, reaching the value of 1.0 of the new parameter  $(\text{H}_2(\text{l})/\text{TIC}) * 48,000$  announced the onset of instability, but this happened approximately on the same day when the VFA/TIC ratio increased above

0.4. The acid formation is a rapid process. Some processes are likely to require overload suppression at an early stage. Given that the detection limit of  $H_2(l)$  of the amperometric sensor is  $0.5 \mu\text{g dm}^{-3}$ , which corresponds to a partial pressure of  $H_2(g)$  of 10 Pa, and some literature reports an incipient overload normally from 2 Pa [9], it is appropriate to search for the more sensitive sensor. Furthermore, the robustness and service life of the amperometric sensor in the sludge environment is not very satisfactory. The thermal conductivity detector should meet the requirements, but there may be a problem with sensitivity. Furthermore, the course of  $H_2(l)$  concentration should be correlated with the concentration of acids determined by GC-MS or isotachopheresis.

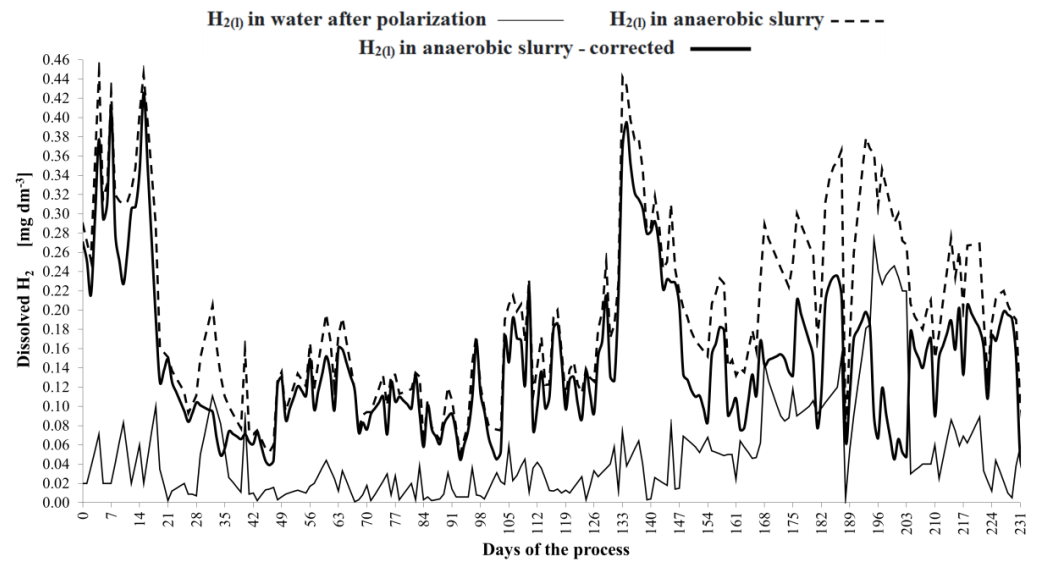

Figure 6. Dissolved  $H_2$  concentration.

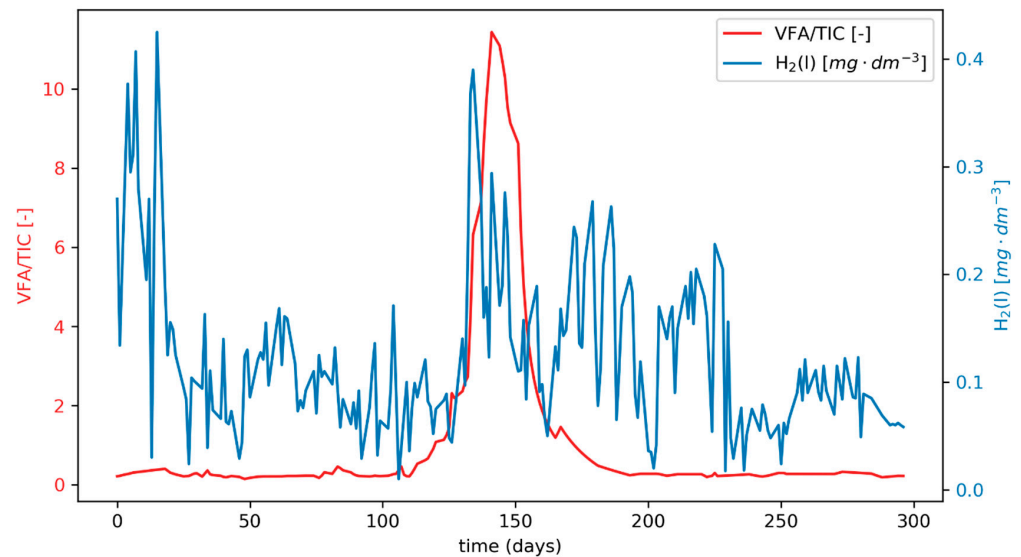

Figure 7. Dissolved  $H_2$  versus VFA/TIC ratio.

The graph in Figure 7 depicts the values of the VFA/TIC and  $H_2(l)$  variables during the experiment. We have computed the Pearson correlation coefficient of these variables, and the result is 0.331, with the  $p$ -value almost 0. The linear correlation between these two variables is very weak, as may be seen from the graph. The values of the  $H_2(l)$  variable do not follow the VFA/TIC variable course. The amount of dissolved hydrogen is not affected by the reactor overloading, and other factors play a role in its concentration change.

#### 4. Conclusions

The laboratory experiment confirmed the possibility of using an amperometric microsensor of dissolved hydrogen to detect the instability of the anaerobic digestion process. Unfortunately, the detection limit of the specific sensor used was not low enough to fully reveal the beginnings of overloading. So far, it has not been possible to prove that the newly proposed process stability parameter in the form of the ratio of dissolved hydrogen concentration and neutralization capacity would significantly help to detect overload. The first statistical evaluation of the relationship shows that there should be a linear correlation between the VFA/TIC and  $H_2(l)$ , but it is affected by the overloading of the reactor. Deep experiments need to be performed to evaluate the relationships.

**Author Contributions:** D.P. was responsible for the laboratory work, performing the experiments. J.R. is responsible for the study design and the main ideas. J.P. was responsible for data analysis, K.S. was responsible of the overall paper preparation and language, R.B. focused on the overall experiment and its relevantness. All authors have read and agreed to the published version of the manuscript.

**Funding:** The work was supported by the Ministry of Education, Youth and Sports of the Czech Republic under the projects ERDF “Institute of Environmental Technology—Excellent Research” [No. CZ.02.1.01/0.0/0.0/16\_019/0000853], Large Research Infrastructure ENREGAT [No. LM2018098], and the Operational Programme Research, Development and Education [No. CZ.02.1.01./0.0/0.0/17\_049/0008419 COOPERATION].

**Institutional Review Board Statement:** Not applicable.

**Informed Consent Statement:** Not applicable.

**Data Availability Statement:** The data presented in this study are available on request from the corresponding author. The data are not publicly available due to its nature and continuous work performed on the devices. The data will be published when we prepare then to publicable state.

**Conflicts of Interest:** The authors declare no conflict of interest.

#### References

1. Gujer, W.; Zehnder, A.J.B. Conversion processes in anaerobic digestion. *Water Sci. Technol.* **1983**, *15*, 127–167.
2. Mužík, O.; Kára, J. Možnosti Výroby a Využití Bioplynu v ČR. Available online: <https://biom.cz/cz/odborne-clanky/moznost-vyroby-a-vyuziti-bioplynu-v-cr> (accessed on 17 January 2020).
3. Dohányos, M.; Záborská, J.; Jeníček, P. *Anaerobní Technologie v Ochráně Životního Prostředí*; Ministerstvo životního prostředí ČR: Praha, Czech Republic, 1996; 172p, ISBN 80-85368-90-0.
4. Dohányos, M. Problematika Řízení a Kontroly Bioplynových Stanic. Available online: <https://www.czba.cz/problematika-rizeni-a-kontroly-bioplynovych-panic.html> (accessed on 10 November 2019).
5. Tvrzník, P.; Zeman, L.; Haitl, M. Bioplynové Stanice z Pohledu Výživy Zvířat. Available online: <https://vuzv.cz/wp-content/uploads/2018/03/Studie-Zeman-bioplynky-na-web-2013.pdf> (accessed on 6 January 2020).
6. Méndez-Acosta, H.O.; Palacios-Ruiz, B.; Alcaraz-González, V.; González-Álvarez, V.; García-Sandoval, J.P. A robust control scheme to improve the stability of anaerobic digestion processes. *J. Process Control* **2010**, *20*, 375–383. [CrossRef]
7. Feitkenhauer, H.; von Sachs, J.; Meyer, U. On-line titration of volatile fatty acids for the process control of anaerobic digestion plants. *Water Res.* **2020**, *36*, 212–218. [CrossRef]
8. Yuan, H.; Zhu, N. Progress in inhibition mechanisms and process control of intermediates and by-products in sewage sludge anaerobic digestion. *Renew. Sustain. Energy Rev.* **2016**, *58*, 429–438. [CrossRef]
9. Dohányos, M. Anaerobní Reaktor Není Černou Skřínkou—Teoretické Základy Anaerobní Fermentace. Available online: <http://biom.cz/cz/odborne-clanky/anaerobni-reaktor-neni-cernou-skrinkou-teoreticke-zaklady-anaerobni-fermentace> (accessed on 29 November 2019).
10. Cord-Ruwisch, R.; Mercz, T.I.; Hoh, C.Y.; Strong, G.E. Dissolved Hydrogen Concentration as an On-Line Control Parameter for the Automated Operation and Optimization of Anaerobic Digesters. *Biotechnol. Bioeng.* **1997**, *56*, 626–634. Available online: <https://www.ncbi.nlm.nih.gov/pubmed/18642334> (accessed on 3 March 2020). [CrossRef]
11. Pauss, A.; Samson, R.; Guiot, S. Continuous measurement of dissolved  $H_2$  in an anaerobic reactor. *Biotechnol. Bioeng.* **1990**, *35*, 492–501. [CrossRef] [PubMed]
12. Srinivasan, V.S.; Tarcy, G.P. Adaptation of Clark oxygen electrode for monitoring hydrogen gas. *Anal. Chem.* **1981**, *53*, 928–929. [CrossRef]

13. Schelter, M.; Zosel, J.; Berthold, F.; Oelßner, W.; Guth, U.; Meinsberg Kurt-Schwabe Research Institute. Measurement of dissolved gases in anaerobic biogenic media. In Proceedings of the SENSOR+TEST Conferences 2011, Nürnberg, Germany, 7–9 June 2011; pp. 654–658, ISBN 978-3-9810993-9-3. [[CrossRef](#)]
14. Archer, D.B.; Hilton, M.G.; Adams, P.; Wiecko, H. Hydrogen as a process control index in a pilot scale anaerobic digester. *Biotechnol. Lett.* **1986**, *8*, 197–202. [[CrossRef](#)]
15. Strong, G.E.; Cord-Ruwisch, R. An in situ dissolved-hydrogen probe for monitoring anaerobic digesters under overload conditions. *Biotechnol. Bioeng.* **1995**, *45*, 63–68. [[CrossRef](#)] [[PubMed](#)]
16. Dannelun, H.M.; Petersson, L.-G.; Söderberg, D.; Lundström, I. A hydrogen sensitive Pd-MOS structure working over a wide pressure range. *Appl. Surf. Sci.* **1984**, *17*, 259–264. [[CrossRef](#)]
17. Drosch, B. *Process Monitoring in Biogas Plants*; IEA Bioenergy: Paris, France, 2013; ISBN 978-1-910154-03-8.
18. Wilcox, S.J.; Hawkes, D.L.; Hawkes, F.R.; Guwy, A.J. A neural network, based on bicarbonate monitoring, to control anaerobic digestion. *Water Res.* **1995**, *29*, 1465–1470. [[CrossRef](#)]
19. Aktiengesellschaft, D.S. Mochen: Biogas Plant Having State Monito-Ring for Fermentation. 2009. eP2379696A1, C12M1/107, C12P5/02. Available online: <https://patentscope.wipo.int/search/en/detail.jsf?docId=EP30281988> (accessed on 10 March 2020).
20. Nguyen, D.; Gadhamshetty, V.; Nitayavardhana, S.; Khanal, S.K. Automatic process control in anaerobic digestion technology: A critical review. *Bioresour. Technol.* **2015**, *193*, 513–522. [[CrossRef](#)] [[PubMed](#)]
21. Liu, J.; Olsson, G.; Mattiasson, B. Control of an anaerobic reactor towards maximum biogas production. *Water Sci. Technol.* **2004**, *50*. [[CrossRef](#)]
22. Gaida, D.; Wolf, C.; Bongards, M. Feed control of anaerobic digestion processes for renewable energy production: A review. *Renew. Sustain. Energy Rev.* **2017**, *68 Pt 2*, 869–875. [[CrossRef](#)]
23. EN 15933:2012. *Sludges, Treated Biowaste, Soils and Wastes—Determination of pH*; BSI: London, UK, 2012.
24. EN 15934:2012. *Sludges, Treated Biowaste, Soils and Wastes—Calculation of the Total Solids Content after Determination of the Drying Residue or Water Content*; BSI: London, UK, 2012.
25. EN 15935:2012. *Sludges, Treated Biowaste, Soils and Wastes—Determination of Loss on Ignition*; BSI: London, UK, 2012.
26. Lossie, U. *Targeted Control of Biogas Plants with the Help of FOS/TAC*; FOS/TAC Analysis; HACH Lange Services: Salford, UK, 2008.