

# A Reference-Model-Based Artificial Neural Network Approach for a Temperature Control System

## **Authors:**

Song Xu, Seiji Hashimoto, YuQi Jiang, Katsutoshi Izaki, Takeshi Kihara, Ryota Ikeda, Wei Jiang

*Date Submitted:* 2020-02-02

*Keywords:* temperature control, I-PD control, reference model, artificial neural networks

## **Abstract:**

Artificial neural networks (ANNs), which have excellent self-learning performance, have been applied to various applications, such as target detection and industrial control. In this paper, a reference-model-based ANN controller with integral-proportional-derivative (I-PD) compensation has been proposed for temperature control systems. To improve the ANN self-learning efficiency, a reference model is introduced for providing the teaching signal for the ANN. System simulations were carried out in the MATLAB/SIMULINK environment and experiments were carried out on a digital-signal-processor (DSP)-based experimental platform. The simulation and experimental results were compared with those for a conventional I-PD control system. The effectiveness of the proposed method was verified.

*Record Type:* Published Article

*Submitted To:* LAPSE (Living Archive for Process Systems Engineering)

*Citation (overall record, always the latest version):*

LAPSE:2020.0137

*Citation (this specific file, latest version):*

LAPSE:2020.0137-1

*Citation (this specific file, this version):*



LAPSE:2020.0137-1v1

*DOI of Published Version:* <https://doi.org/10.3390/pr8010050>

*License:* Creative Commons Attribution 4.0 International (CC BY 4.0)

Article

# A Reference-Model-Based Artificial Neural Network Approach for a Temperature Control System

Song Xu <sup>1,2,†,‡</sup>, Seiji Hashimoto <sup>1,\*</sup>, YuQi Jiang <sup>1,‡</sup>, Katsutoshi Izaki <sup>3,‡</sup>, Takeshi Kihara <sup>3,‡</sup>, Ryota Ikeda <sup>3,‡</sup> and Wei Jiang <sup>2,‡</sup> 

<sup>1</sup> Division of Electronics and Informatics, Gunma University, Kiryu 376-8515, Japan; xusong0922@outlook.com (S.X.); t172d003@gunma-u.ac.jp (Y.J.)

<sup>2</sup> Department of Electrical Engineering, Yangzhou University N.196 Huayang West Road, Yangzhou 225-000, China; jiangwei@yzu.edu.cn

<sup>3</sup> R & D Division, RKC Instrument Inc., Tokyo 146-8515, Japan; izaki@rkinst.co.jp (K.I.); kihara\_t@rkinst.co.jp (T.K.); ikeda\_r@rkinst.co.jp (R.I.)

\* Correspondence: hashimotos@gunma-u.ac.jp; Tel.: +81-0277-30-1741

† Current address: 1-5-1 Tenjin-cho, Kiryu, Gunma 376-8515, Japan.

‡ These authors contributed equally to this work.

Received: 31 October 2019; Accepted: 19 December 2019; Published: 1 January 2020



**Abstract:** Artificial neural networks (ANNs), which have excellent self-learning performance, have been applied to various applications, such as target detection and industrial control. In this paper, a reference-model-based ANN controller with integral-proportional-derivative (I-PD) compensation has been proposed for temperature control systems. To improve the ANN self-learning efficiency, a reference model is introduced for providing the teaching signal for the ANN. System simulations were carried out in the MATLAB/SIMULINK environment and experiments were carried out on a digital-signal-processor (DSP)-based experimental platform. The simulation and experimental results were compared with those for a conventional I-PD control system. The effectiveness of the proposed method was verified.

**Keywords:** artificial neural networks; reference model; I-PD control; temperature control

## 1. Introduction

Industrial processes, such as thermal and manufacturing processes, are becoming increasingly important, and processing high requirements for operation performance. Heating systems are used in thermal processes, which have a wide range of industrial applications, especially in food processing. A variety of control methods have been proposed for the precise temperature control and improved the transient response of heating systems. Conventional control methods, especially proportional-integral-derivative (PID) control, have become commonly used due to their simplicity and applicability, even for multi-point temperature control systems [1–5].

However, due to the nonlinearity and large lag of heating systems, the performance of a PID control system may not meet the requirements. A series-connected fuzzy-proportional integral control method has been proposed to improve control performance [6]. In addition, to achieve more precise control, a mathematical model of the controlled object is required. Numerous identification methods have been used to build such models. One of the most popular methods is the step response method [7–10].

Based on the mathematical plant model, some advanced compensation methods have been proposed to improve the performance of conventional PID control, including Smith estimator predictive control [11], self-adaptation control [12], generalized predictive control [13], fuzzy control [14] and model predictive control [15].

For complex heating process systems, the mathematical model cannot be obtained precisely. Data-driven approaches have been proposed for controlling such systems [16], Some optimization methods have also been proposed [17].

A problem with typical heating system control methods is that once the parameters of the control system are defined, they cannot be adjusted while the system is in operation. Plant perturbations thus lead to instability of the control system. Artificial neural networks (ANNs), which have excellent self-learning ability and can adjust their parameters online to handle variations of the controlled system, have received increasing attention for industrial applications. With advancements in machine learning methods, ANNs has been applied to a number of industrial applications, such as the development of an occupancy prediction model [18], improvement of thermal comfort indices [19], and data measurement in temperature control systems [20–24]. For a thermal process system with strong nonlinearity, large lag and strong coupling, an adaptive system can improve control performance in terms of the transient response and overshoot [25–27].

In the present study, to improve the transient response of a heating system with strong nonlinearity and large lag, a reference-model-based ANN control method is proposed. In the proposed method, the system is driven by the error signal between the reference model output and the real system output. This error signal is used as the teaching signal for the ANN. The ANN controller is added to an I-PD control system to appropriately adjust the control input. The rest of the paper is organized as follows. The configuration of the proposed system is described in detail in Section 2. The simulation and experimental results for the proposed method are presented in Sections 3 and 4, respectively. The results are compared with those for a conventional I-PD control system. The conclusions are given in Section 5.

## 2. Configuration of ANN with Reference Model System

In this section, we describe the configuration of the proposed ANN control system with a reference model. Figure 1 shows the block diagram of the reference-model-based ANN control system.

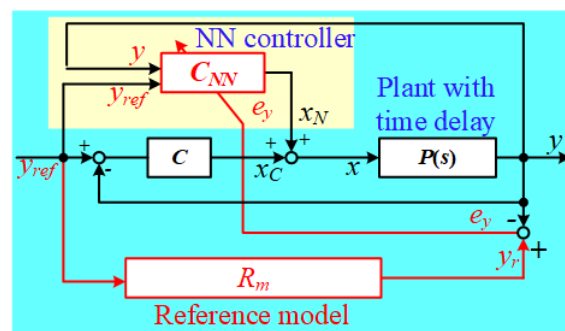

Figure 1. Block diagram of proposed reference-model-based ANN control system.

For simplicity, the controlled object is expressed as a first order plus time delay (FOPTD) model. In Figure 1,  $y_{ref}$  is the set reference value for the system,  $e_y$  is the teaching signal for the ANN controller, which is calculated as the error between the output  $y_r$  of reference model  $R_m$  and the output temperature  $y$ ,  $C$  is a conventional PID controller (in this paper, an I-PD configuration is employed), and  $x$  is the control input, which is the sum of the ANN controller output  $x_N$  and IPD output  $x_C$ . The reference model  $R_m$  is designed based on the controlled object, thus it can provide the reference output temperature with the same time delay. The explanation of the control system is divided into four main parts.

### 2.1. Controlled Object with Time Delay

The controlled object is the thermal processing system, which can be represented as a FOPTD system. With its large delay time, the transfer function of the plant can be expressed as Equation (1),

where  $K$  is the steady-state gain of the output temperature against the input signal,  $T$  is the time constant of the plant, and  $\tau$  is the delay time of the response. The step response of the plant is shown in Figure 2. Since this model is only suitable to the autotuning method of the I-PD controller, it is not required to design the ANN controller itself.

$$P(s) = \frac{K}{Ts + 1} e^{-\tau s} \quad (1)$$

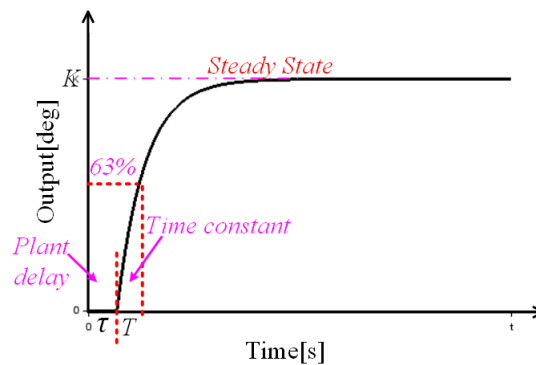

Figure 2. Step response of FOPTD plant.

## 2.2. Conventional I-PD Control

Considering that the ANN controller needs time to learn and train its parameters, and will mainly act after finishing training, a conventional I-PD controller is designed for the control of the initial state. The block diagram of I-PD controller is shown in Figure 3, where  $k_f$  is the feed-forward gain used to decide the system response speed (0: slow; 0.5: middle; 1: fast),  $T_i$  is the integral time constant,  $T_d$  is the differential time constant,  $\eta$  is the gain of the low-pass filter (LPF) which is necessary for the feasibility of the derivative action, and  $K_p$  is the proportional gain of the controller.

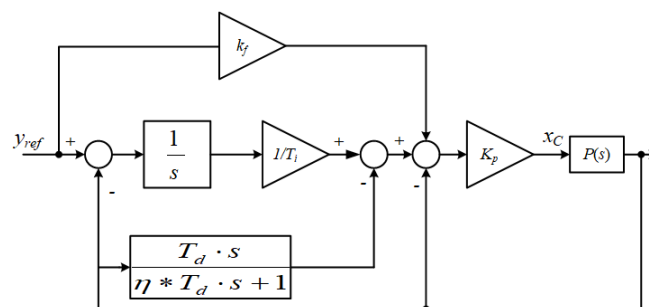

Figure 3. Structure of conventional I-PD control.

Stability is one of the most important factors of a controller. Several methods have been proposed for controller stability analysis [28,29]. Because the parameters of the I-PD controller are designed based on the Ziegler–Nichols rule (step response method), stability is ensured [30]. These values are determined by  $\tau$ ,  $K$  and  $T$  in Equation (1). The I-PD parameter  $K_p$ ,  $T_i$  and  $T_d$  can be calculated as Equations (2)–(4), respectively.

$$K_p = 1.2 \frac{T}{\tau} \quad (2)$$

$$T_i = 0.5T \quad (3)$$

$$T_d = 2\tau \quad (4)$$

### 2.3. ANN Controller

In order to realize model free control and auto learning for reference model output tracking, a multi-layer ANN controller is introduced into the I-PD control system. In the proposed system, the ANN controller has one input layer, two hidden layers, and one output layer. The two hidden layers have 10 neurons, and thus the structure of the ANN controller is 2-10-10-1.

In this system, the reference value of the system  $y_{ref}$  and the output temperature  $y$  are set as the input signals of the ANN.  $x_N$  is the output value of the ANN. The calculation process, from the input  $NN_{in}$  to the output  $NN_{out}$ , is shown in Equation (5), where  $NN_{in}$  is the input vector and  $NN_{out}$  is the output vector, the  $W_1$ ,  $W_2$  and  $W_3$  are the weight of neurons,  $\theta_1$  and  $\theta_2$  are the offset value for each hidden neuron, and  $f(\cdot)$  is the neuron activation function.

$$NN_{out} = W_3 * f(W_2 * f(W_1 * NN_{in} + \theta_1) + \theta_2) \quad (5)$$

Regarding self-learning, the back-propagation algorithm is applied for the weight training and neuron bias update. Assuming that neuron  $j$  is a neuron in hidden layer connected to the output neuron  $k$ . The signal flow analysis is under the  $n$ th iteration (i.e.,  $n$ th training sample). The neuron  $j$  is fed by a set of function signals produced by a layer of neurons to its left. Thus, the output of neuron  $j$  and  $k$  can be obtained as Equations (6) and (7), respectively, where  $m$  is the total number of inputs (excluding the bias) applied to neuron  $j$  (here,  $m = 10$ ). The synaptic weight  $w_{j0}$  (corresponding to the fixed input  $y_0 = +1$ ) equals the bias  $\theta_j$  applied to neuron  $j$ .

$$y_j(n) = f\left(\sum_{i=0}^m w_{ji}(n)y_i(n)\right) \quad (6)$$

$$y_k(n) = f\left(\sum_{j=1}^m w_{kj}(n)y_j(n)\right) \quad (7)$$

The back-propagation begins at the output layer of the ANN controller. The error signal is used as the teaching signal for the neurons, the error signal at  $n$ th iteration is defined as Equation (8), which is provided by the difference between the reference model output  $y_{ref}$  and the real plant output  $y_r$ , as is shown in Figure 1.

$$e_k(n) = y_r(n) - y(n) \quad (8)$$

According to the back-propagation algorithm, the corrections of the weight  $w_{kj}$  is that in Equation (9) and  $\Delta w_{kj}$  is obtained as shown in Equation (10), where  $\alpha$  is the learning gain, and  $\varepsilon(n)$  is the instantaneous value of the error energy.

$$w_{kj}(n+1) = w_{kj}(n) + \Delta w_{kj}(n) \quad (9)$$

$$\Delta w_{kj}(n) = -\alpha \frac{\partial \varepsilon(n)}{\partial w_{kj}(n)} \quad (10)$$

The weight correction for neuron  $j$  is obtained as shown in Equation (11).  $\Delta w_{ji}(n)$  is expressed as shown in Equation (12), where  $\delta_j(n)$  is the local gradient of neuron  $j$ , and can be calculated as shown in Equation (13),  $m_k$  is the total number of output layer (here,  $m_k = 1$ ).

$$w_{ji}(n+1) = w_{ji}(n) + \Delta w_{ji}(n) \quad (11)$$

$$\Delta w_{kj}(n) = -\alpha \frac{\partial \varepsilon(n)}{\partial w_{kj}(n)} = \alpha \delta_j(n) y_i(n) \quad (12)$$

$$\delta_j(n) = f'(v_j(n)) \sum_{k=1}^{m_k} \delta_k(n) w_{kj}(n) \quad (13)$$

The neuron bias needs to be adjusted. The correction is determined by  $\delta(n)$ . The bias correction for neuron  $j$  at the  $n$ th iteration is expressed as Equation (14), where  $\beta$  is the bias training gain.

$$\theta_j(n+1) = \theta_j(n) - \beta\delta_j(n) \quad (14)$$

To improve the self-learning ability of the ANN controller, the *ReLU* neuron activation function, shown in Equation (15) has been applied, and its derivative is shown in Equation (16).

$$f(x) = \begin{cases} x, & x > 0 \\ 0, & x \leq 0 \end{cases} \quad (15)$$

$$f'(x) = \begin{cases} 1, & x > 0 \\ 0, & x \leq 0 \end{cases} \quad (16)$$

#### 2.4. Reference Model-Based ANN Control System

The reference model, which is based on the plant transfer function, is applied to provide the training signal for the ANN controller and also help to prevent the over learning of the NN controller. Reducing the memory required to store the output can make the controller realization easy, thus the approximation of the dead time needs to be introduced. There are several approximation methods, such as graphical approximation and Padé approximation. Here, the Padé approximation method is applied, as given by Equation (17).

$$e^{-\tau s} \approx \frac{1}{\left(\frac{\tau s}{2} + 1\right)^2} \quad (17)$$

The reference model settings are based on the approximated plant model. To improve the transient response speed, gain  $R$  is added to the plant time constant in the approximated model as shown in Equation (18).

$$R(s) \approx \frac{K}{T * R * s + 1} \times \frac{1}{\left(\frac{\tau s}{2} + 1\right)^2} \quad (18)$$

### 3. Simulation Results

#### 3.1. Comparison Simulation with Conventional Error Feedback ANN Method

To verify the proposed control method, the comparison with conventional error feedback ANN control method needs to be carried out. The structure of the conventional error feedback ANN control method is shown in Figure 4, where the output of the IPD controller is used as the learning signal of the NN controller. In this comparison simulation, the control object is freely chosen as Equation (19), which only has 1 s delay time, and the reference model is designed as introduced above. Both the conventional error feedback ANN control method and the proposed reference-model-based ANN control method has been applied to this control object, a step signal from 100 to 105 is applied as the reference value which will be repeated several times, and have both first step response and the last step response compared.

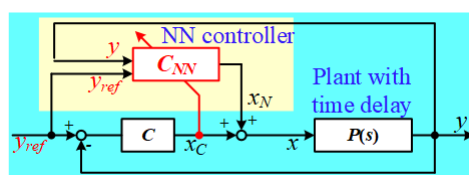
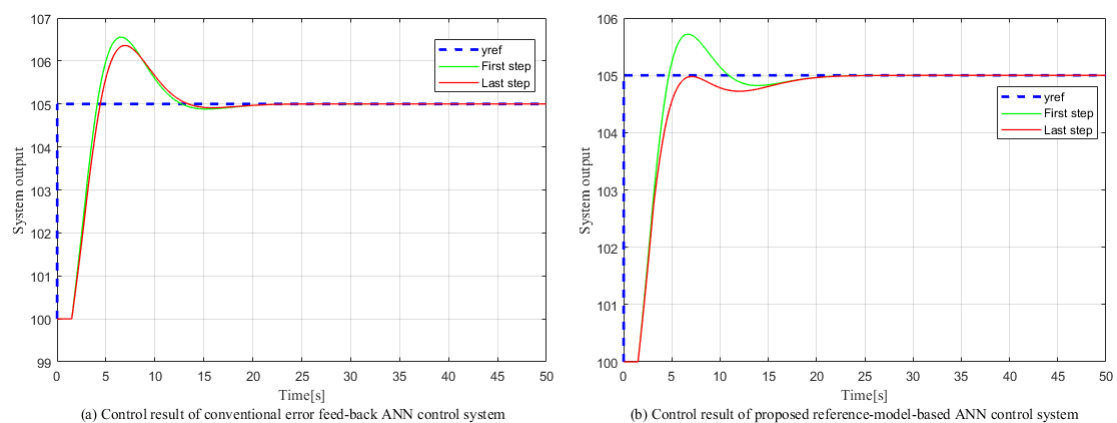

Figure 4. Structure of conventional error feed back ANN control method.

$$P(s) = \frac{540}{225s + 1} e^{-s} \quad (19)$$

Figure 5a,b respectively show the time response of the conventional error feedback ANN control system and the proposed reference-model-based ANN control system. From the simulation results, the first step response and the last step response of the conventional error feedback ANN control are almost the same, which means that after repeating several times the conventional feedback ANN control method can't improve the system response. However, by introducing the proposed reference-model-based ANN method, compared with the first step response the last step response has been improved by the overshoot and transient response. Thus, we state that our proposed reference-model-based ANN control method is better than the conventional error feedback ANN method.



**Figure 5.** Comparison simulation results. (a) Time response of the conventional error feed back ANN control method and (b) Time response of the proposed reference-model-based ANN control method.

### 3.2. Experimental Setup and System Identification

To verify the control efficiency of the reference-model-based ANN control method, the controlled object was based on a real plant system. A step response experiment was performed to obtain the transfer function for the controlled object. The experimental setup is shown in Figure 6. It includes a digital signal processor (DSP) as the temperature controller. The system has four coupled channels. Each channel has two independent heaters and one temperature sensor. The temperature sensor transforms the temperature (0–400 °C) into an output voltage (0–10 VDC). The heaters are controlled by the solid-state relay (SSR has shown in Figure 6), and the SSR is driven by pulse width modulation (PWM) signals. The temperature can be controlled through the duty ratio of the PWM signals.

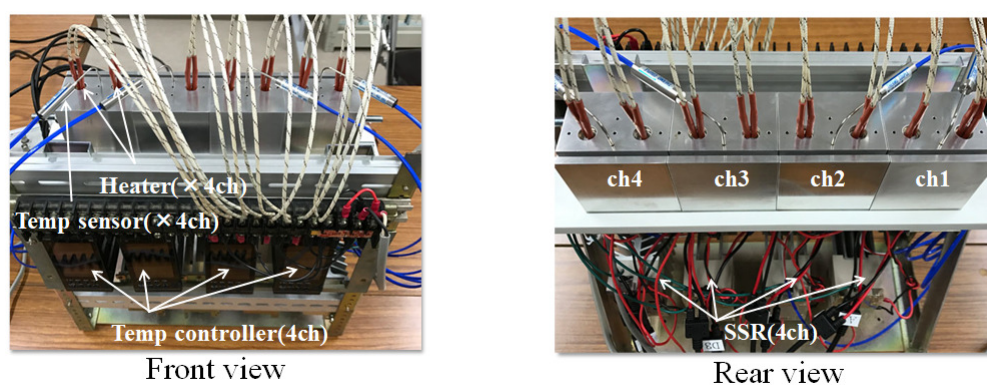

**Figure 6.** Experimental setup.



Channel Ch1 is defined as the input channel (heating channel) and Ch4 is defined as the output channel. The step response method was used for system identification. The plant was identified as shown in Equation (20).

$$P(s) = \frac{2.36}{2626s + 1} e^{-524s} \quad (20)$$

### 3.3. Simulation Results

The simulation was carried out in the MATLAB/SIMULINK environment. In the simulation, the controlled object was based on the identified plant (Equation (20)). Hence, the reference model was expressed as Equation (21). Here,  $R$  was set to 0.01.

$$R(s) \approx \frac{2.36}{26.26s + 1} \times \frac{1}{\left(\frac{524}{2}s + 1\right)^2} \quad (21)$$

The I-PD parameters were determined by the plant parameters using the Ziegler–Nichols method, as described above. The parameters were  $K_p = 10.3$ ,  $T_i = 838$ , and  $T_d = 209$ . Moreover, the hyper-parameters of the ANN were determined as  $\alpha = 1 \times 10^{-9}$  and  $\beta = 2 \times 10^{-5}$ , these two parameters are designed by try and error method. The initial value of the weight was set to a random value between  $-1$  and  $1$ .

The simulation can be divided into two steps, namely the ANN learning period and positive direction control (we define control temperature from  $100^\circ\text{C}$  to  $105^\circ\text{C}$  as the positive direction control). In the first step, the temperature goes from  $0^\circ\text{C}$  to  $100^\circ\text{C}$ , and the control switches from I-PD controller to the ANN controller. In the second step, the reference is set to  $105^\circ\text{C}$ , and the temperature is controlled from  $100^\circ\text{C}$  to  $105^\circ\text{C}$ . This particular step will be repeated several times to obtain the first step and last step results. Figure 7a,b respectively show the time response of the controlled system and the results of the control system for temperature increase from  $100^\circ\text{C}$  to  $105^\circ\text{C}$ . The results were compared with those obtained using a conventional I-PD control system with feed-forward gain  $k_f = 0$  (slow) and  $k_f = 1$  (fast).

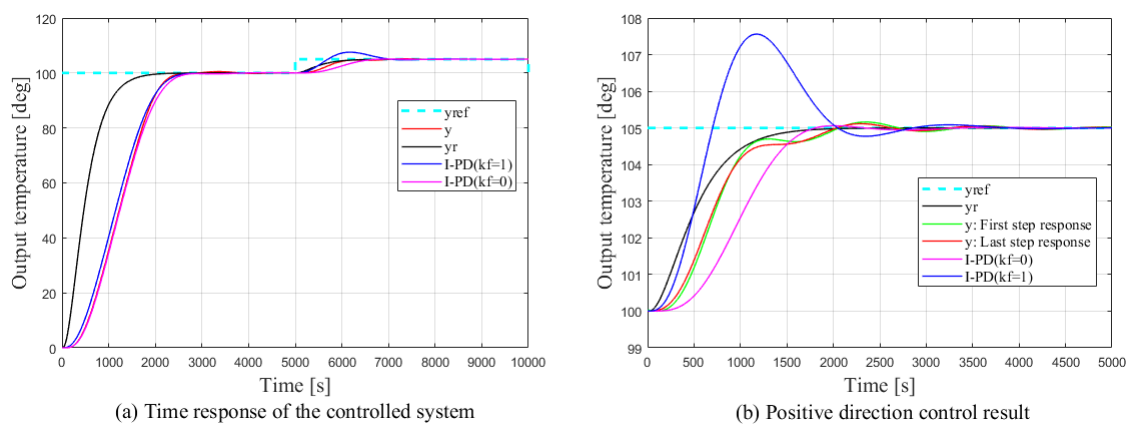

**Figure 7.** Simulation results. (a) Time response for the controlled system and (b) results of positive direction control for proposed control system and conventional I-PD control system for temperature increase from  $100^\circ\text{C}$  to  $105^\circ\text{C}$  obtained from simulation.

From the simulation results, the response time for the conventional I-PD control system is about  $1300\text{ s}$  and that for the proposed ANN control system is about  $700\text{ s}$ , an improvement of almost 46%. Moreover, because the first step response is almost the same as the last step response, the learning process ended at the beginning of the first step. The system response follows the reference model, although there is a slight deviation. These results show that the proposed system improved control efficiency. And from the simulation results, the last step response are almost the same, meaning the



learning of the NN control was nearly finished by the time of the first step response, thus realizing the quick-learning.

Figures 8a,b, respectively, show the outputs of the ANN and I-PD controllers and the control input, which is expressed as the sum of the ANN and I-PD outputs. As shown, the output of the I-PD controller is initially positive, about 140%, and that of the ANN controller is initially negative, about  $-40\%$ . In this condition, the I-PD controller plays a dominant role. As the system approaches the setpoint, the output of the I-PD controller becomes negative, about  $-180\%$ , and that of the ANN controller becomes positive, about  $225\%$ . The control efficiency switches from the I-PD controller to the ANN controller. The control input respects the sum of the I-PD and ANN output; the steady-state value is about  $45\%$ .

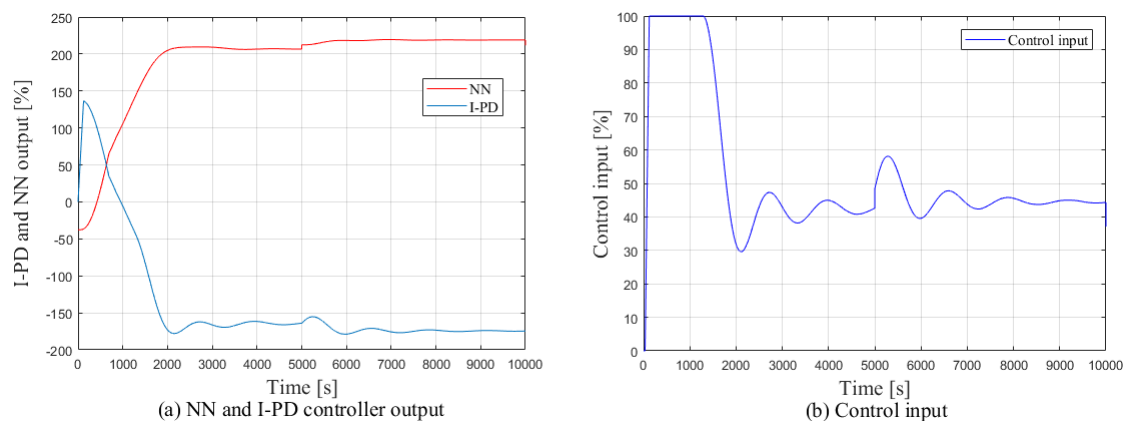
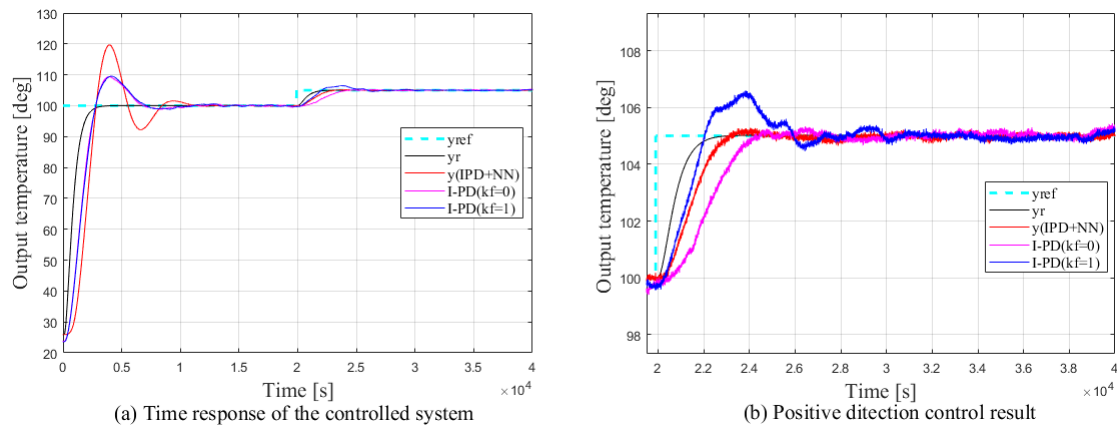

**Figure 8.** (a) Outputs of ANN controller and I-PD controller and (b) control input obtained from simulation.

#### 4. Experimental Results

Experiments with the proposed reference-model-based ANN control method were carried out using parameter values identical to those used in the simulation. The experimental setup was the same as that shown in Figure 6. The condition of experiments are as the following: sampling period is  $0.1\text{ s}$ , controller sampling bit is 12 bits, sensor resolution is  $0.1\text{ }^{\circ}\text{C}$  and the air conditioner is set as  $25\text{ }^{\circ}\text{C}$ . In the experiments, as in the simulation, to verify the control efficiency of the proposed method, the results were compared with those for a conventional I-PD control system with feed-forward gain  $k_f = 0$  (slow) and  $k_f = 1$  (fast). The experiments were carried out by controlling the temperature of Ch1 from  $100\text{ }^{\circ}\text{C}$  to  $105\text{ }^{\circ}\text{C}$ . The results for the output temperature are shown in Figure 9. The temperature change from room temperature to  $100\text{ }^{\circ}\text{C}$  is defined as the learning period of the ANN controller, and the temperature change from  $100\text{ }^{\circ}\text{C}$  to  $105\text{ }^{\circ}\text{C}$  is the control result for the controlled system.

The response time of the controlled system is about  $2300\text{ s}$  and about  $1900\text{ s}$  for the conventional I-PD system with  $k_f = 0$  and  $k_f = 1$ , respectively, and about  $2000\text{ s}$  for the proposed ANN control system. Although the response time for the proposed system is  $5\%$  slower than that for the I-PD ( $k_f = 1$ ) system, it is  $15\%$  faster than that for the I-PD ( $k_f = 0$ ) system. Although the I-PD ( $k_f = 1$ ) system has the fastest response, it exhibits an overshoot of  $1.5\text{ }^{\circ}\text{C}$ , which is about  $30\%$  of the reference value. The proposed ANN control system and the I-PD ( $k_f = 0$ ) system do not exhibit overshoot. Thus, control effectiveness is improved by the proposed method. The simulation and experimental results both verify the proposed reference-model-based ANN control method.



**Figure 9.** Experiment results. (a) Time response for the controlled system and (b) results of positive direction control for proposed control system and conventional I-PD control system for temperature increase from 100 °C to 105 °C obtained from experiments.

Figure 10a,b respectively show the output of the ANN and I-PD controllers and the control input, which is expressed as the sum of the ANN and I-PD output. As shown, the output of the I-PD controller is initially positive, about 140%, and that of the ANN controller is initially negative, about  $-120\%$ . Under this condition, the I-PD controller plays a dominant role. As the system approaches the setpoint, the output of the I-PD controller becomes negative, about  $-25\%$ , and that of the ANN controller becomes positive, about 63%. The control efficiency switches from the I-PD controller to the ANN controller. And the control input respects the sum of the I-PD output and ANN output; the steady-state value is about 38%.

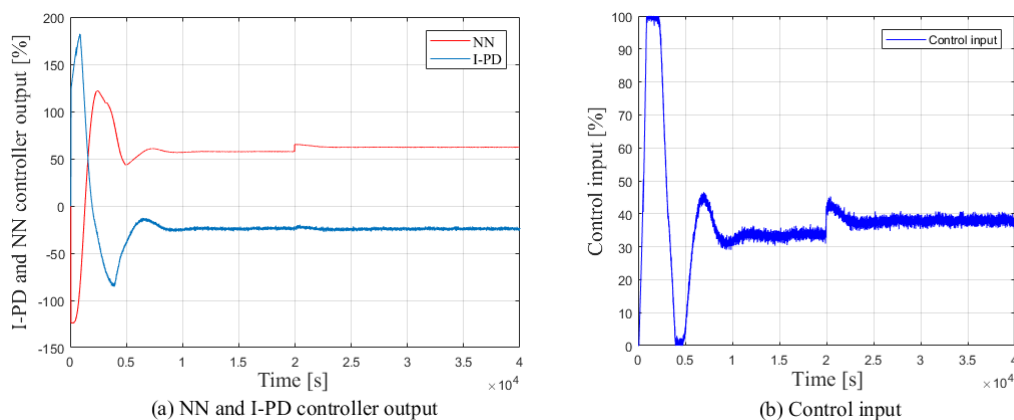

**Figure 10.** (a) Outputs of ANN controller and I-PD controller and (b) control input obtained from experiments.

## 5. Conclusions

In this paper, a reference-model-based ANN control method is proposed for temperature control systems. The error between the real system output and the reference model output is used to drive the system and this error signal is used as the teaching signal for the ANN controller. The whole control system is a combination of the ANN controller and the I-PD controller. The simulation was carried out in the MATLAB/SIMULINK environment to verify the control system. Experiments were carried out on a DSP based temperature system platform. Both simulation and experimental results were quantitatively compared with those of the conventional I-PD control system to evaluate the improvement in the transient response. The control effectiveness of the proposed method was successfully verified. Although the transient response time and overshoot have been improved by the proposed ANN

control method, there still remain some shortcomings such as the necessity for the reference model to be based on the plant model, and presently the proposed method is only applied to the FOPTD plant.

**Author Contributions:** Conceptualization, S.H. and S.X.; methodology, S.H.; software, S.X. and Y.J.; validation, S.X., S.H., Y.J. and W.J.; formal analysis, S.H. and S.X.; investigation, S.H.; resources, W.J.; data curation, S.X. and Y.J.; writing—original draft preparation, S.X.; writing—review and editing, S.H.; visualization, W.J.; supervision, W.J.; project administration, S.H., K.I., T.K. and R.I.; funding acquisition, S.H., K.I., T.K., R.I. and W.J. All authors have read and agreed to the published version of the manuscript.

**Funding:** This research received no external funding.

**Acknowledgments:** In this section you can acknowledge any support given which is not covered by the author contribution or funding sections. This may include administrative and technical support, or donations in kind (e.g., materials used for experiments).

**Conflicts of Interest:** The authors declare no conflict of interest.

## References

1. Suda, N. *PID Control*; Asakura Publishing: Tokyo, Japan, 1992.
2. Oshima, M. *Process Control Systems*; Corona Publishing: New York, NY, USA, 2003.
3. Goodwin, G.C.; Fraebe, S.F.; Salgado, M.E. *Control System Design*; Prentice Hall: Upper Saddle River, NJ, USA, 2001.
4. Morari, M.; Zafiriou, E. *Robust Process Control*; Prentice Hall: Upper Saddle River, NJ, USA, 1992.
5. Maciejowski, J.M. *Multivariable Feedback Design*; Addison Wesley: Boston, MA, USA, 1989.
6. Ko, J.S.; Huh, J.H.; Kim, J.C. Improvement of Temperature Control Performance of Thermolectric Dehumidifier Used Industry 4.0 by the SF-PI Controller. *Processes* **2019**, *7*, 98. [[CrossRef](#)]
7. Song, B.Q.; Mills, J.K.; Liu, Y.H.; Fan, C.Z. Nonlinear Dynamic Modeling and Control of a Small-Scale Helicopter. *Int. J. Control Automat. Syst.* **2010**, *8*, 534–543. [[CrossRef](#)]
8. Fujimori, A.; Ohara, S. Order Reduction of Plant and Controller in Closed Loop Identification based on Joint Input-Output Approach. *Int. J. Control Automat. Syst.* **2017**, *15*, 1217–1226. [[CrossRef](#)]
9. Yao, Y.; Yang, K.; Huang, M.; Wang, L. A state-space model for dynamic response of indoor air temperature and humidity. *Build. Environ.* **2013**, *64*, 26–37. [[CrossRef](#)]
10. Yao, Y.; Yang, K.; Huang, M.; Wang, L. A technique for identification of linear systems. *IEEE Trans. Autom. Control* **1965**, *AC-10*, 461–464.
11. Fliess, M.; Marquez, R.; Mounier, H. An extension of predictive control: PID regulators and Smith predictors to some linear delay systems. *Int. J. Control* **2002**, *75*, 728–743. [[CrossRef](#)]
12. Bai, J.; Wang, S.; Zhang, X. Development of an adaptive Smith predictor-based self-tuning PI controller for an HVAC system in an experiment room. *Energy Build.* **2008**, *40*, 2244–2252. [[CrossRef](#)]
13. Xu, M.; Li, S. Practical generalized predictive control with decentralized identification approach to HVAC systems. *Energy Convers. Manag.* **2007**, *48*, 292–299. [[CrossRef](#)]
14. Zhang, J. Experimental study on a novel fuzzy control method for static pressure reset based on the maximum damper position feedback. *Energy Build.* **2015**, *108*, 215–222. [[CrossRef](#)]
15. Afram, A.; Janabi-Sharifi, F. Theory and applications of HVAC control systems—A review of model predictive control (MPC). *Build. Environ.* **2014**, *72*, 343–355. [[CrossRef](#)]
16. Gao, Z.; Nguang, S.K.; Kong, D.X. Data-driven approaches for complex industrial systems. *IEEE Trans. Ind. Inform.* **2013**, *9*, 2210–2212. [[CrossRef](#)]
17. Gao, Z.; Nguang, S.K.; Kong, D.X. Advances in Modelling, Monitoring, and Control for Complex Industrial Systems. *Complexity* **2019**, *2019*, 2975083. [[CrossRef](#)]
18. Ryu, S.H.; Moon, H.J. Development of an occupancy prediction model using indoor environmental data based on machine learning techniques. *Build. Environ.* **2016**, *107*, 1–9. [[CrossRef](#)]
19. Megri, A.C.; Naqa, I.E. Prediction of the thermal comfort indices using improved support vector machine classifiers and nonlinear kernel functions. *Indoor Built Environ.* **2016**, *25*, 6–16. [[CrossRef](#)]
20. Badia, M.; McCarthy, R. Data estimation methods for predicting temperatures of fruit in refrigerated containers. *Biosyst. Eng.* **2016**, *151*, 251–272.
21. Mercier, S.; Marcos, B. Identification of the best temperature measurement position inside a food pallet for the prediction of its temperature distribution. *Int. J. Refrig.* **2017**, *76*, 147–159. [[CrossRef](#)]

22. Badia, M.; Qian, J.P.; Fan, B.L. Artificial neural networks and thermal image for temperature prediction in apples. *Food Bioprocess Technol.* **2012**, *9*, 1089–1099. [[CrossRef](#)]
23. Nunes, M.C.N.; Nicometo, M.; Emond, J.P.; Badia-Melis, R.; Uysal, I. Improvement in fresh fruit and vegetable logistics quality: Berry logistics field studies. *Philos. Trans. R. Soc. A Math. Phys. Eng. Sci.* **2014**, *372*, 20130307. [[CrossRef](#)]
24. Raab, V.; Petersen, B.; Kreyenschmidt, J. Temperature monitoring in meat supply chains. *Br. Food J.* **2011**, *113*, 1267–1289. [[CrossRef](#)]
25. Katic, K.; Li, R.L.; Verharrrt, J.; Zeiler, W. Neural network based predictive control of personalized heating systems. *Energy Build.* **2018**, *174*, 199–213. [[CrossRef](#)]
26. Li, X.M.; Zhao, T.Y.; Zhang, J.L.; Chen, T.T. Predication control for indoor temperature time-delay using Elman neural network in variable air volume system. *Energy Build.* **2017**, *154*, 545–552. [[CrossRef](#)]
27. Mercier, S.; Uysal, I. Neural network models for predicting perishable food temperatures along the supply chain. *Biosyst. Eng.* **2018**, *171*, 91–100. [[CrossRef](#)]
28. Thenozhi, S.; Yu, W. Stability analysis of active vibration control of building structures using PD/PID control. *Eng. Struct.* **2014**, *81*, 208–218. [[CrossRef](#)]
29. Guerrero, J.; Torres, J.; Creuze, V.; Chemori, A.; Campos, E. Saturation based nonlinear PID control for underwater vehicles: Design, stability analysis and experiments. *Mechatronics* **2019**, *61*, 96–105. [[CrossRef](#)]
30. Ziegler, J.G.; Nichols, N.B. Optimum settings for automatic controllers. *Trans. ASME* **1942**, *64*, 759–768. [[CrossRef](#)]



© 2020 by the authors. Licensee MDPI, Basel, Switzerland. This article is an open access article distributed under the terms and conditions of the Creative Commons Attribution (CC BY) license (<http://creativecommons.org/licenses/by/4.0/>).