

A Review of the Design and Control of Free-Piston Linear Generator

Authors:

Xuezhen Wang, Feixue Chen, Renfeng Zhu, Guilin Yang, Chi Zhang

Date Submitted: 2018-09-21

Keywords: internal combustion engine, piston motion control, linear electric machine, free-piston

Abstract:

The Free-piston linear generator (FPLG) is a novel energy converter which can generate electrical energy and is regarded as a potential technology for solving the restriction of the short driving range of electric vehicles. Getting rid of the crank and flywheel mechanism, FPLG obtains some advantages of a variable compression ratio, compact size, and highly-efficient power generation. Linear electric machine (LEM) design and piston motion control are two key technologies of FPLG. However, they are currently the main obstacles to the favorable performance of FPLG. LEM being used to drive the piston motion or generate electric energy is an integrated design including a motor/generator. Various types of LEMs are investigated, and suitable application scenarios based on advantages and disadvantages are discussed. The FPLG's controller is used to ensure stable operation and highly-efficient output. However, cycle-to-cycle variations of the combustion process and motor/generator switching make it difficult to improve the performance of the piston motion control. Comments on the advantages and disadvantages of different piston motion control methods are also given in this paper.

Record Type: Published Article

Submitted To: LAPSE (Living Archive for Process Systems Engineering)

Citation (overall record, always the latest version):

LAPSE:2018.0700

Citation (this specific file, latest version):

LAPSE:2018.0700-1

Citation (this specific file, this version):

LAPSE:2018.0700-1v1

DOI of Published Version: <https://doi.org/10.3390/en11082179>

License: Creative Commons Attribution 4.0 International (CC BY 4.0)

Review

A Review of the Design and Control of Free-Piston Linear Generator

Xuezhen Wang ¹ , Feixue Chen ^{1,2}, Renfeng Zhu ^{1,2}, Guilin Yang ¹ and Chi Zhang ^{1,*}

¹ Key Laboratory of Robotics and Intelligent Manufacturing Equipment Technology of Zhejiang Province, Ningbo Institute of Materials Technology & Engineering, Chinese Academy of Sciences, Ningbo 315201, China; wangxzh@nimte.ac.cn (X.W.); chenfeixue@nimte.ac.cn (F.C.); zhurenfeng@nimte.ac.cn (R.Z.); glyang@nimte.ac.cn (G.Y.)

² University of Chinese Academy of Sciences, Beijing 100049, China

* Correspondence: zhangchi@nimte.ac.cn; Tel.: +86-574-8666-9754

Received: 16 July 2018; Accepted: 14 August 2018; Published: 20 August 2018



Abstract: The Free-piston linear generator (FPLG) is a novel energy converter which can generate electrical energy and is regarded as a potential technology for solving the restriction of the short driving range of electric vehicles. Getting rid of the crank and flywheel mechanism, FPLG obtains some advantages of a variable compression ratio, compact size, and highly-efficient power generation. Linear electric machine (LEM) design and piston motion control are two key technologies of FPLG. However, they are currently the main obstacles to the favorable performance of FPLG. LEM being used to drive the piston motion or generate electric energy is an integrated design including a motor/generator. Various types of LEMs are investigated, and suitable application scenarios based on advantages and disadvantages are discussed. The FPLG's controller is used to ensure stable operation and highly-efficient output. However, cycle-to-cycle variations of the combustion process and motor/generator switching make it difficult to improve the performance of the piston motion control. Comments on the advantages and disadvantages of different piston motion control methods are also given in this paper.

Keywords: free-piston; linear electric machine; piston motion control; internal combustion engine

1. Introduction

Nowadays, electric vehicles are considered to be the main alternative to conventional automobiles [1]. Whereas, due to limitations in battery technology, a short driving range becomes an obstacle to the development of electric vehicles. The FPLG being used as a range extender can be an effective measure to solve this drawback [2]. Benefitting from the elimination of the slider-crank mechanism, it has the advantages of a variable compression ratio, compact size, and highly-efficient power generation [3,4]. The compression ratio depends on the distance between the piston position and the cylinder head. Unlike a conventional internal combustion engine, the piston dead centers and stroke length in the FPLG are not restrained by the mechanical structure. Hence, this allows the compression ratio to be adjusted by controlling the position of the generator mover and thereby regulating the top dead center. Different fuels such as gasoline, hydrogen, and methane can therefore be used in the FPLG with their optimal compression ratio without structural modification of the combustion engine [5]. In addition, compared to conventional range extenders, the FPLG is an integrated system between a LEM and free piston engine with small size and low mass [6]. In terms of system efficiency, friction and thermal losses are less due to the reduction of lateral forces and the faster expansion near the top dead center (TDC) [7].

The piston moves freely between TDC and bottom dead center (BDC), and its motion is determined by the resultant force that is acting upon it, including gas pressure force, electro-magnetic force, and rebound force [8–10]. The piston motion must be controlled by an electronic control system—an electronic crankshaft, which is an integrated control of combustion parameters or control variables of the LEM and rebound devices [5]. Moreover, there are cycle-to-cycle variations and periodic large disturbances during the combustion process. As a result, piston motion control is still the biggest challenge of FPLG [11]. Besides, LEM is not only used as a power output unit but also a control unit for adjusting the movement of the piston. For the FPLG, LEM requires high reliability, high precision, high efficiency, and so on. Various structures of LEM designed by many teams around the world have been investigated, but none of these meet all of the requirements due to the short stroke, high frequency, and high acceleration.

In order to lucubrate the current existing problems, this paper reviews the key technologies of LEM design and FPLG motion control. Firstly, several basic structures of FPLG are introduced, and both their advantages and disadvantages are analyzed. Afterwards, according to the different types of structure, corresponding advantages and disadvantages of LEMs are presented. With respect to the existing LEMs, they are classified according to the different flux path and topology structures in the third section. Finally, different starting methods are introduced based on the FPLG's structure. In terms of power generation stage, piston motion control strategies are divided into three forms and introduced based on their control variables. They include three categories: active combustion parameters control, active LEM control, and the mixed control between combustion and LEM.

2. Basic Configuration of FPLG

As shown in Figure 1, FPLG consists of the internal combustion engine (ICE), LEM, or an alternative rebound device. In Figure 1A, firstly the piston assembly is to be pushed by energy from fuel combustion to accelerate, and then to be decelerated by rebound device (from TDC to BDC); secondly the piston assembly is reversely accelerated by rebound device, and slowed down to zero speed by combustion chamber (from BDC to TDC). As the piston moves to TDC, in-cylinder air–fuel mixture is compressed for the next ignition. Repeating this process above, FPLG can keep the continuous reciprocating motion and generate electrical energy.

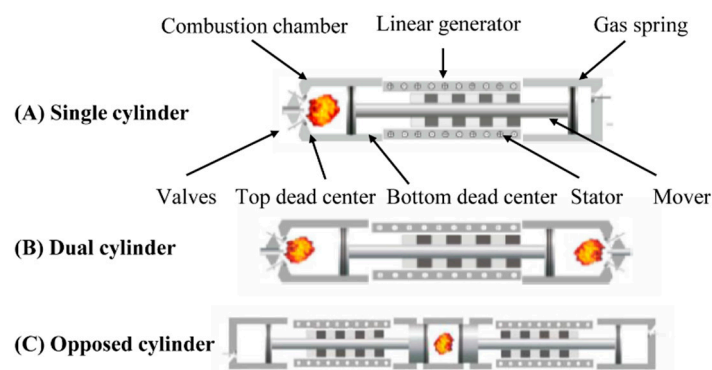

Figure 1. Illustration of the principle of the free-piston linear generator [2,12].

The combustion chamber is the energy input port of FPLG, and it is one of the crucial components. The number of combustion chambers determines the complexity of the energy input and piston motion control, as well as the design of LEMs [4]. Furthermore, the FPLG's vibration behavior is affected by the layout structure of combustion chambers [3]. According to the number of combustion chambers, the existing FPLGs can be mainly classified into three categories: single-cylinder, dual-cylinder, and opposed-cylinder.

The first type of single-cylinder FPLG typically includes a rebound device for pushing the piston from BDC to TDC. In one reciprocating cycle, the single combustion chamber only ignites fuel once, so that it can provide more time to reduce the variation of TDC caused by the combustion variation from the last combustion cycle [10,13,14]. Combined with a controllable rebound device, the free-piston of single-cylinder FPLG can produce precise reciprocating motion. As a result, the single-cylinder FPLG has better controllability.

The dual-cylinder FPLG is equipped with two combustion chambers and can be designed in a compact size for higher output power [15,16]. During the alternating combustion of the chambers, the LEM's mover cuts the magnetic force lines back and forth to produce electric energy. Under a two-stroke combustion cycle, each stroke of the free-piston motion is a power stroke. While one chamber is in the combustion stroke, the other is in the compression stroke that is immediately followed by the combustion. Hence, the combustion state at one end can directly affect the position of TDC on the other side. Compared with the single-cylinder FPLG, it is more difficult to ensure the consistency of the piston motion and dead centers.

The combustion chamber of the opposed-cylinder FPLG is placed between the two LEMs, it is also addressed as the bilateral single-cylinder FPLG, as shown in Figure 1C. When the fuel burns, the pistons on both sides are simultaneously pushed. The explosive force produced by combustion at each piston can be counteracted by the opposite direction of forces. This structure is therefore well-balanced [17]. However, the piston synchronization motion of the both pistons determines the compression ratio, and it has a significant effect on the consistency of combustion state and electrical power output. Therefore, the issue of synchronization control of opposed-cylinder FPLG has received considerable critical attention through the use of mechanical devices or the LEM control approach [17–19].

3. Classification of FPLG: Different LEMs

LEM is an essential component which converts mechanical energy into electrical energy, and it also can be operated as a motor to start the engine and keep the compression ratio consistent through position control. During the design phase, both LEM performance and manufacturing technology should be taken into consideration [20,21]. Previous studies have pointed out that low moving mass is important to improve the operation frequency, and optimization of the LEM efficiency can significantly reduce the fuel consumption [22]. Besides high efficiency and low moving mass, high power density, good reliability, high dynamic performance, and simple structure are also required for the LEM.

3.1. Different Flux Type Permanent Magnet LEMs

Permanent magnet linear electric machine (PMLEM) is the best option for LEM due to its high efficiency and high power-to-weight ratio. The main kinds of PMLEMs being investigated for the FPLG applications are surface mounted PMLEM (SMPMLEM), transverse flux PMLEM (TFPMLEM), and flux switching PMLEM (FSPMLEM) [23,24].

There are moving-coil and moving-magnet type for SMPMLEMs, and their currents in the windings are orthogonal to the mover motion direction. The moving-magnet SMPMLEMs have surface mounted magnets on the mover and windings on the stator, while the moving-coil SMPMLEMs have the opposite structure. The moving-coil LEMs require flexible cable leads which are subject to mechanical stress and vibrations. As the operation frequency and power increase, the thrust of the moving-coil type per moving mass significantly reduces due to the increasing requirement of efficiency and difficulties in heat dissipation [25]. Therefore, the moving-coil linear generator is not suitable for high frequency and high power applications. Compared to the moving-coil type, the moving-magnet LEMs are more suitable for high frequency operation due to the good reliability and lower moving mass which have been verified by many researches [6,26,27].

The configuration of PMs used in SMPMLEMs can generally be classified into radially magnetized, axially magnetized, and Halbach magnetized according to the magnetization direction [28]. Since the ideal Halbach array is too difficult to manufacture, the quasi-Halbach structure with a simpler form

is a more reasonable option. The virtually “self-shielding” characteristic of the quasi-Halbach can even enhance the magnetic flux in the air gap while it weakens the magnetic flux passing through the support structure, as shown in Figure 2. Thus the yoke thickness of the mover core can be much thinner and even the employment of nonmagnetic and lightweight materials (aluminum alloy for an example) can be an acceptable option [29]. The quasi-Halbach array showed the best average performance in force capacity, moving mass according to the simulation researches, so it can improve the overall performance of the SMPMLEMs [23].

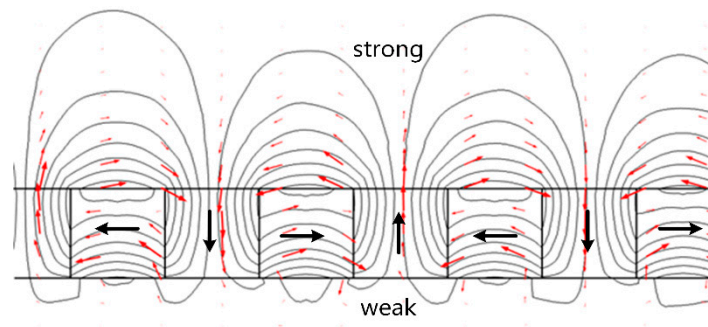

Figure 2. The flux distribution of the quasi-Halbach array.

The TFPMLEMs have flux concentrated PMs on the mover and transverse winding in stators, and the current flow is parallel to the direction of motion as shown in Figure 3. TFPMLEMs can achieve high power density owing to independent magnetic load and electric load [16]. However, most traditional TFPMLEMs suffer from poor power factor due to the large flux leakage and high manufacturing cost due to the complex structure. Therefore, many optimization researches have been conducted to overcome these drawbacks. The flux leakage analysis of the TFPMLEMs pointed out that reduction of the armature flux leakage can increase the power factor, and different stator topologies are investigated [16,30]. During the design process, a three dimensional (3D) finite element analysis (FEA) is necessary due to the complex geometry and fully 3D flux path [31].

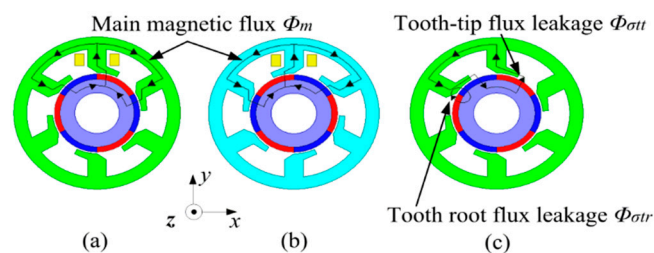

Figure 3. Magnetic flux paths of machine [16]. (a) Main magnetic flux path 1 of stator core; (b) Main magnetic flux path 2 of stator core; (c) Transverse-flux leakage path.

The mover of FSPMLEM is made of slotted iron, the stator consists of PMs and transverse windings for each phase, as shown in Figure 4 [31]. As a result, FSPMLEMs have superior reliability due to their simple and rugged mover structure, and they are featured with high force density, high efficiency but high force ripple [32,33].

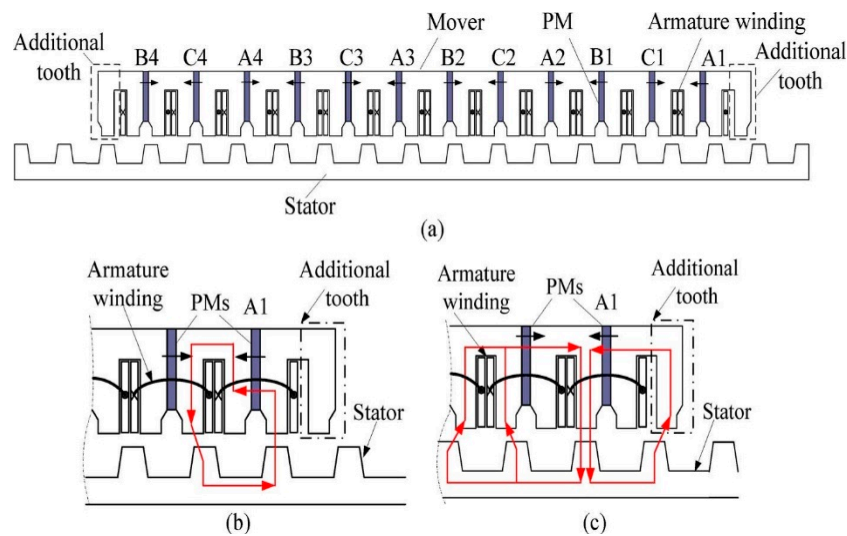

Figure 4. Cross section of the flux switching permanent magnet linear electric machine (FSPMLEM) and its unbalanced magnetic circuit principle [33]. (a) Cross section of the FSPMLEM; (b) Mover position with the positive maximum flux linkage in coil A1; (c) Mover position with the negative maximum flux linkage in coil A1.

In comparison with SMPMLEMs, the simulation results showed that the TFPMLEMs exhibited lower cogging force, lower thrust fluctuation, higher PM use rate, and higher efficiency. And numerical optimization results of 3D FEA concluded that the FSPMLEMs were uncompetitive compared to the TFPMLEMs due to the large flux leakage even with improved tooth structure. However, complex structure and low power factor for TFPMLEMs remain to be solved [23,31,34]. Compared to SMPMLEMs, both of them suffered from a large moving mass which would result in low motion frequency and low dynamic response.

3.2. Different Topology Structures of PMLEMs

According to the topology structures, there are two main types of PMLEMs: flat-type and tubular-type. The main advantages of the tubular-type are the zero net radial force between the mover and stator, and no end-windings. However, the magnetic rings and the tubular stator are difficult to manufacture, while further in a LEM with constrained external size, the sectional areas of the winding are limited by the diameter of the magnetic rings. Although the manufacturing of the flat-type LEM is relatively simple, it has some drawbacks in structure, such as end-windings. So far, both types are under investigation by the researchers all over the world [4].

J. Wang from the University of Sheffield analyzed the design and experimental characterization of a three-phase tubular modular PM machine equipped with quasi-Halbach magnetized magnets, as shown in Figure 5. They discussed the suitability of the tubular-type SMPMLEMs, and found that they had advantages of high power density, high efficiency, low cogging force, and low moving mass, and could improve the overall performance of the FPLG system [26].

S. Goto et al. from Toyota Central R&D Labs Inc. developed two generations of prototypes as shown in Figures 6 and 7. In Figure 8, the main differences between them are as follows: the mover of the first prototype consisted of iron poles and permanent magnets, whereas the second prototype had a Halbach array of permanent magnets; the stator of the first prototype had four turns windings in each slot, whereas there were nine turns windings with rectangular wire of the second prototype. The comparison showed that the second prototype has higher efficiency [1], which verified that the employment of a Halbach array could improve the LEM performance.

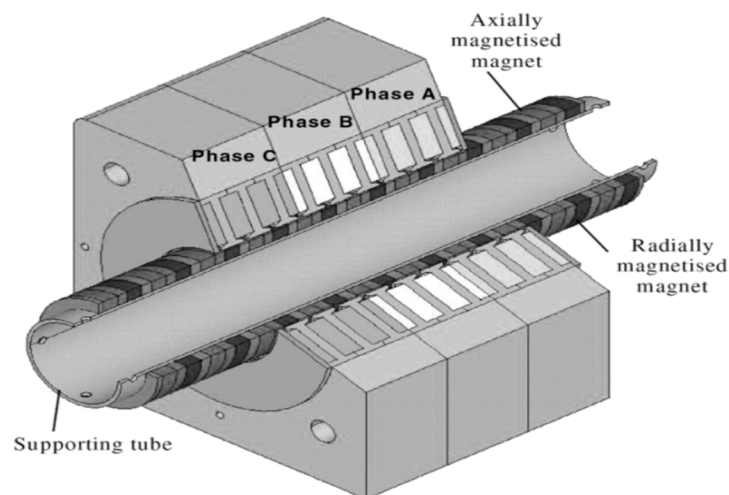

Figure 5. Schematic of three-phase, 10-pole, 9-slot tubular modular PM machine [35].

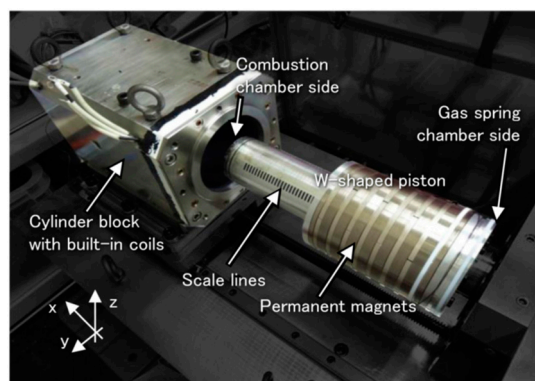

Figure 6. Linear generator structure of the first prototype of Toyota Central R&D [14].

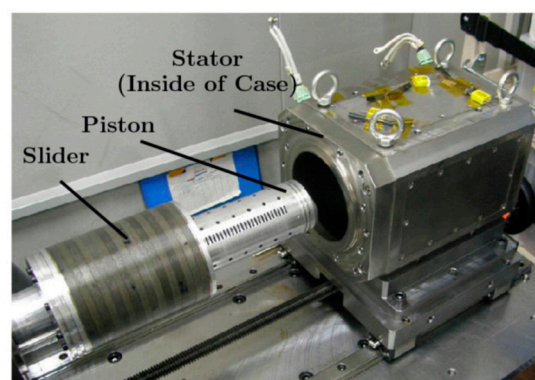

Figure 7. Linear generator structure of the second prototype of Toyota Central R&D [1].

Ping Zheng et al. designed two generations of TFPMLEM prototypes which were characterized by low flux leakage and simple structure. The first generation prototype was a Z type TFPMLEM, as shown in Figure 9. Upon the in-depth flux leakage analysis of Z type TFPMLEM, they proposed a tubular staggered-tooth TFPMLEM, as shown in Figure 10. The 3D equivalent magnetic circuit model was built, the analytical solution of electromagnetic force was obtained, and optimization results with force density of $2.697 \times 10^5 \text{ N/m}^3$ and the force ripple of 2.78% were achieved by the 3D finite element method [16,34].

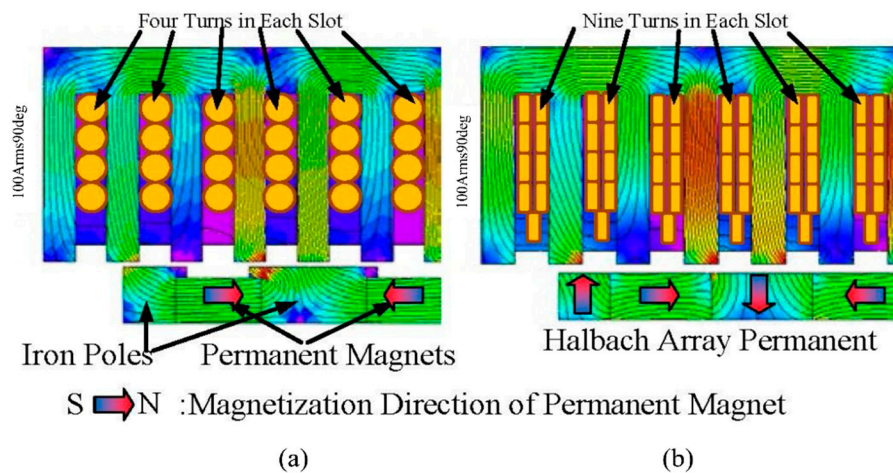

Figure 8. Two generations of prototype at Toyota Central R&D [1]. (a) First prototype; (b) Second prototype.

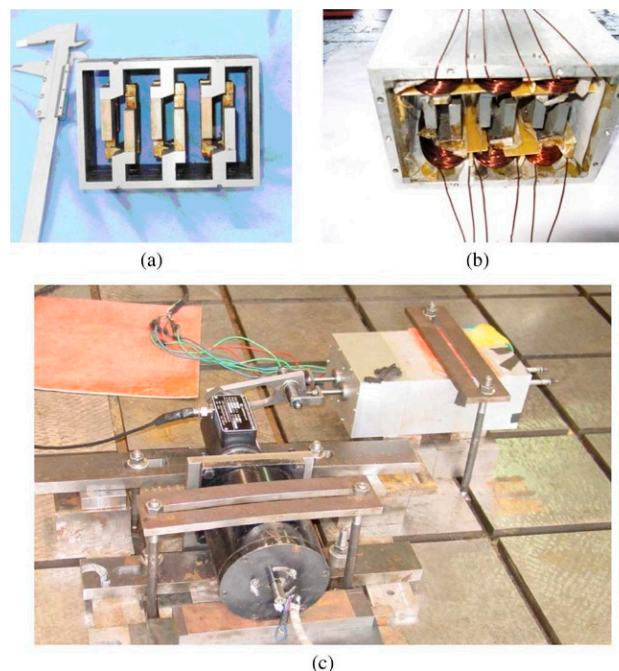

Figure 9. Pictures of the prototype machine and test bench [34]. (a) Stator core; (b) Stator windings; (c) Test bench.

Q. Li et al. from Shanghai Jiaotong University conducted a comparative study between the flat and the tubular SMPMLEMs based on a simulation method, as shown in Figure 11. The finite element analysis showed that the flat alternator had better performance on efficiency, specific power, and current density despite the limitations of structural drawbacks, as shown in Figure 12 [36]. F. Rinderknecht from German Aerospace Center (DLR) analyzed two generations of integrated linear generators. As shown in Figure 13, the first generation was a tubular type linear generator, and his research suggested that the maximization of frequency could improve the power density and a new topology with a low moving mass is needed to increase the core-loss-based frequency. The second generation was a flat type which used two stators around one mover, as shown in Figure 14. The results of the measurement showed that the second generation prototype was superior to the first generation in almost all performance areas, especially a considerable increase in efficiency in the motoring mode [22].

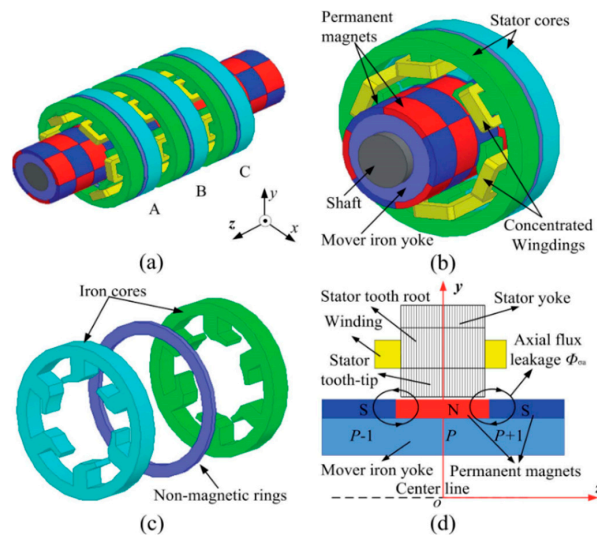

Figure 10. Structure of the staggered-tooth transverse flux PMLEM (TFPMLEM) [16]. (a) Overall structure; (b) One phase of machine; (c) Stator cores and nonmagnetic ring; (d) Side view of machine with one stator core.

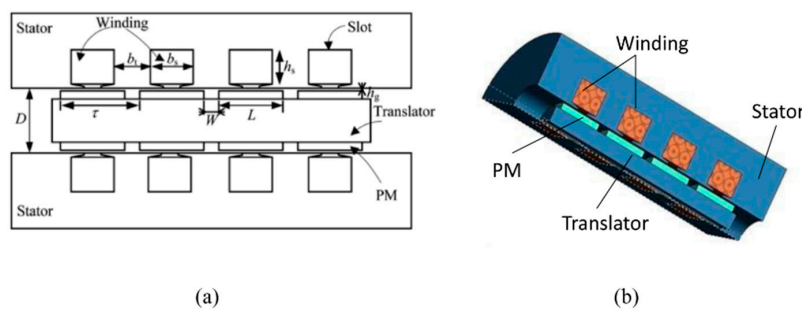

Figure 11. Linear alternator at Shanghai Jiaotong University [36]. (a) Cross-sectional view of flat-type FPLG; (b) Model of tubular linear alternator.

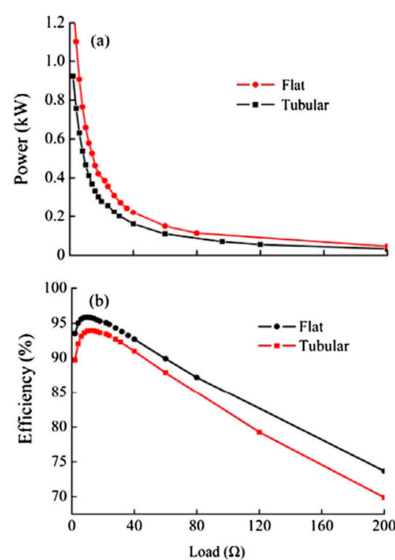

Figure 12. Specific power (a) and efficiency (b) vs. external load [36].

As for hybrid Electric Vehicle (HEV) application, the flat-type can be integrated into the underbody of the vehicles, which provided several advantages such as low center of gravity and more space for the crumple zones at the front [6].

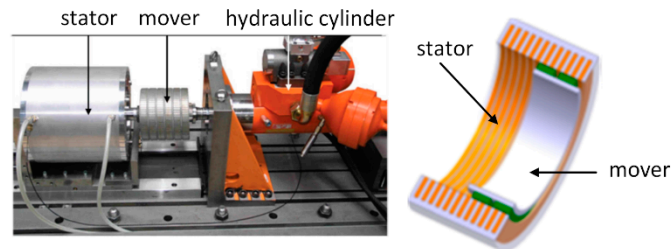

Figure 13. First generation linear generator of DLR [22].

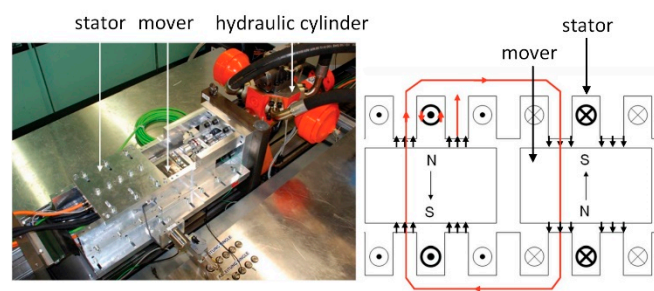

Figure 14. Second generation linear generator of DLR [22].

Among these kinds of PMLEMs, SMPMLEMs show the lowest moving mass, but the power density was not satisfactory. TFPMLEM is a competitive choice in term of power density, however, the power factor is poor due to large flux leakage and the manufacturing cost is relatively high due to their complex structure. And FSPMLEMs are investigated in order to achieve high force density and efficiency. Thus a novel flux switching transverse flux PMLEM which combines the advantages of TFPMLEM and FSPMLEM may be a good choice for the FPLG. For scenarios with space limitations, such as HEV application, the flat-type PMLEM has more advantages.

4. Piston Motion Control

In FPLGs, due to the elimination of the slider-crank mechanism, the resultant force determines the free-piston motion. When the forces acting upon on the piston are disturbed, the consistency of motion trajectory and dead center positions cannot be guaranteed. More importantly, it will affect the compression process, scavenging process, combustion quality, and further produce cycle-to-cycle variations. In particular, under limiting operation conditions such as the dead positions, piston displacement and velocity, the state of reciprocation motion depends on the input and output energy conversion [37,38]. Where the input energy is from fuel burning and the output energy is produced by the resultant force in a cycle. Excessive output energy or insufficient input energy may cause the piston to collide with the cylinder head. Insufficient input or excessive output may result in misfire, undesired compression ratio, or even engine stall, and then an unstable operation in the next cycle. Therefore, the controller design involves input and output energy control. In particular, the input and output energies vary according to the FPLG phase: starting stage or power generation stage.

4.1. Atarting Methods of FPLGs

During the starting stage, the free-piston is at dead stop and an external force is required to accelerate it for compressing the in-cylinder air–fuel mixture during the first few cycles. LEMs can

be used as a prime mover to push the piston conducting reciprocate motion. A rebounding device can also be used as an auxiliary power to start the FPLG system. Different FPLG structures have diverse starting methods. Here, they will be introduced based on the distribution of cylinders, such as single-cylinder, dual-cylinder, or opposed-cylinder.

When FPLG has only one single cylinder, with the help of the rebound device and LEM, the appropriate velocity and compression ratio will be achieved in one cycle, as shown in Figure 15. In [7,10,27,39], the mechanical spring was employed to push the piston back to the top dead center. When starting stage was enabled, the piston was in the intake stroke, and then the mechanical spring was compressed and partially stored the elastic potential energy. Afterwards, the piston was in the compression stroke and was pushed by the elastic force and the electromagnetic force. When the driving energy (including elastic potential and electrical energy) was sufficient, the combustion chamber would reach a specified compression ratio for fuel burning. Similarly, when rebounding device is gas spring, hydraulic system, or auxiliary LEM, their starting methods are the same with mechanical spring [3,9,27,40,41]. Single-cylinder FPLGs could take full advantage of a rebounding device which is used to store energy and then release it, to reach desired combustion conditions. Especially, with this starting method, the peak currents injected could be small in first few cycles.

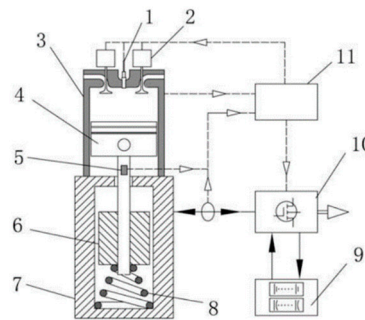

Figure 15. Basic structure of free-piston linear generator (FPLG) at Nanjing University of Science and Technology [7].

When the FPLG has two cylinders, the piston motion is mainly controlled by LEM during the starting process. Some studies focused on the starting process using position feedback or the constant-magnitude motoring force approach [37,42–45]. In order to obtain a desired piston trajectory, the position error serves as a feedback variable to control the thrust force with appropriate value and direction [43]. The feedback control scheme is shown in Figure 16. However, due to the limited rated current of stator coils and insufficient motor force constant, an expected peak compression force cannot push the mover end-to-end in a single stroke. In particular, as the compression ratio increases, a larger electromagnetic force is required. Therefore, a rebound device needs to be operated to provide starting force, which will reduce the LEM current.

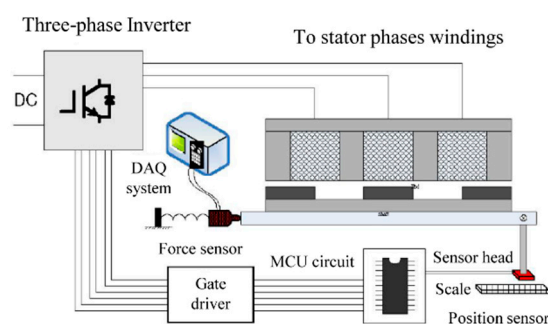

Figure 16. Feedback control scheme for starting the free piston engine [43].

In [42], S. A Zulkifi proposed a rectangular current commutation start-up strategy. The basic principle consists of two aspects: handling LEM in a motoring state via rectangular current commutation, and utilizing reciprocating motion to achieve mechanical resonance. Therefore, with this strategy the compression energy from the current cycle can be absorbed through the compression chamber and used for the next cycle. A low motoring force can be required to cause the piston assembly to initially reciprocate with a small amplitude, as shown in Figure 17. The constant motor force produced is in the same direction of piston motion velocity to profitably increase the piston kinetic energy for the desired compression ratio. However, due to the employment of current open loop control, the compression ratio could not be quite as high as the compression energy gradually increases. Using the same mechanical resonance method, B. Jia designed a closed-loop control strategy coupled with PID compensators, and took piston displacement, velocity, and current as feedbacks, as shown in Figure 18. Ultimately, the compression ratio of combustion chamber was controlled to reach 9:1 [46,47]. The same starting method also was implemented by C. Yuan, in [48].

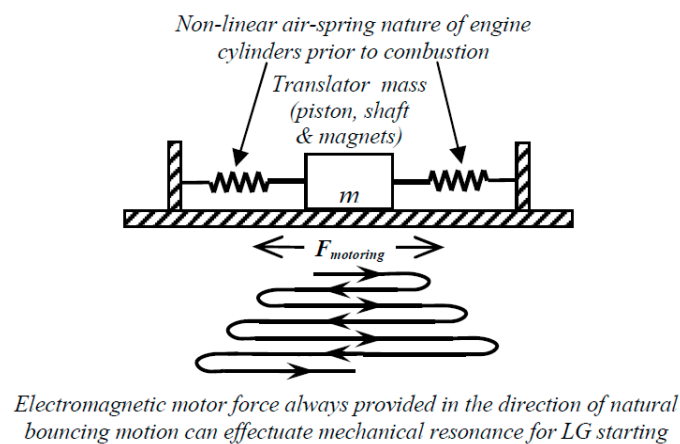

Figure 17. Spring mass representation and mechanical resonance for FPLG starting [42].

Compared with open-loop controller, the closed-loop controller can realize required piston velocity and displacement for ignition more quickly. However, with this method, the control parameters of PID compensators have a significant effect on the magnitude of the current. Especially when the piston is near the TDC and BDC, the actual current would increase due to zero-speed of the piston and larger compression force. Thus, the adaptive adjustment of the control parameters could be a key problem, which requires further investigations.

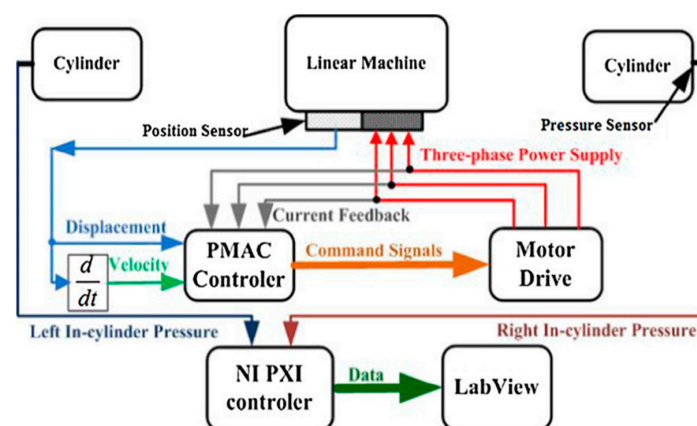

Figure 18. Control system block diagram for the setup at Beijing Institute of Technology [46].

In [17], the opposed-cylinder FPLG was developed, as shown in Figure 19. For starting and maintaining piston motion prior to combustion, a pneumatic drive system was implemented to provide high pressure helium gas. When the start signal was enabled, the piston would get sufficient kinetic energy from high pressure gas in bounce chambers to compress the mixed fuel in central combustion chamber. However, the linear alternators were not used to assist starting, thus it is necessary to generate high gas pressure to overcome friction, gas pressure of central cylinder, and electromagnetic drag force for the sake of reaching specified compression ratio. In [19], the mechanical spring was employed as a rebounding device, which could not be actively controlled to operate piston motion as shown in Figure 20. During the starting process, the LEM was controlled as a motor and its working principle was similar with the single cylinder FPLG equipped with mechanical spring. Especially, the issue of piston synchronization need to be considered for the opposed-cylinder FPLG.

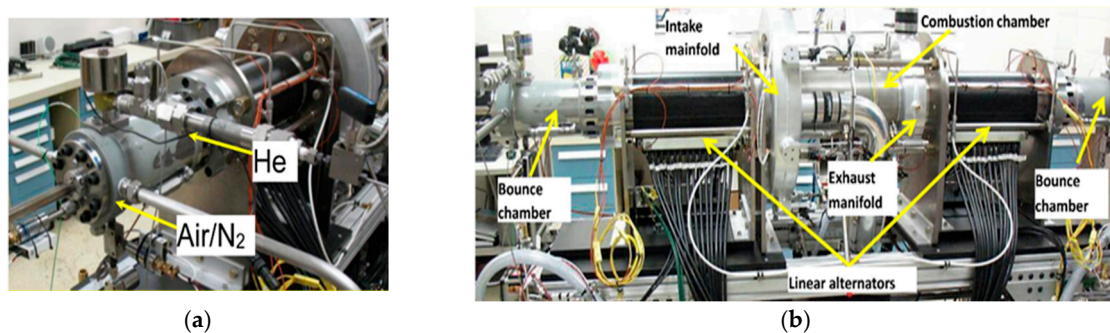

Figure 19. The prototype of opposed-piston FPLG. (a) Diagram of gas supply to bounce chamber; (b) Structure diagram of FPLG.

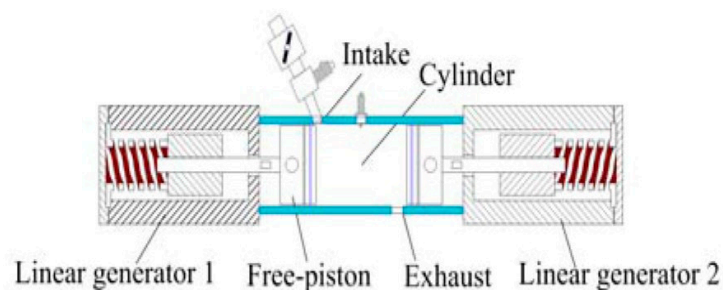

Figure 20. Opposed-piston free-piston linear.

In the starting stage, when LEM is individually used to start FPLG, the input energy is electric energy, which is limited by the armature related current of LEM. When the rebounding device is employed to start and maintain piston motion, the input energy is from high pressure gas or high hydraulic pressure, and is limited by the gas/liquid flow rate. Therefore, the mixed starting mode, including LEM and rebound device, would be a promising starting approach.

4.2. Piston Motion Control during Power Generation Stage

After the starting process, FPLG turns into the next operation state for steady motion. Meanwhile, the dead center piston positions need to be controlled in a stable range for the fixed compression ratio. The prime mover is from the chemical energy of the fuel and the output power mainly generates electricity. Therefore, parameters related to input and output energy could be selected as control variables to control the piston motion. According to control variables, the control method of the free-piston can be categorized as active combustion control, active LEM control, and the mixed control strategy with both combustion and LEM control.

4.2.1. Active Combustion Parameters Control

For active combustion control, piston motion state including piston position, velocity, and dead centers are directly controlled through combustion parameters, such as fuel mass, ignition time, compression ratio, and air–fuel ratio. Nevertheless, LEM is employed to adjust the output power of FPLG system. Mikalsen and Roskilly presented the investigation into the basic control of a single-cylinder FPLG including combustion cylinder, bounce chamber cylinder, and LEM [9,13]. The control variables were fuel injection timing, mass of fuel injected, and the opening and closing timing of bounce pressure valves. As shown in Figure 21, this control scheme consisted of low-level control, piston motion control, and supervisory control systems. At the same time, the dead center positions of piston and bounce pressure were set at the supervisory control level, and they were controlled at piston motion level based on the signal from the low-level control. Due to the good logical structure of the multi-layer control system, this control framework is modified and implemented to control free piston motion by many works of research literature [7,37,49].

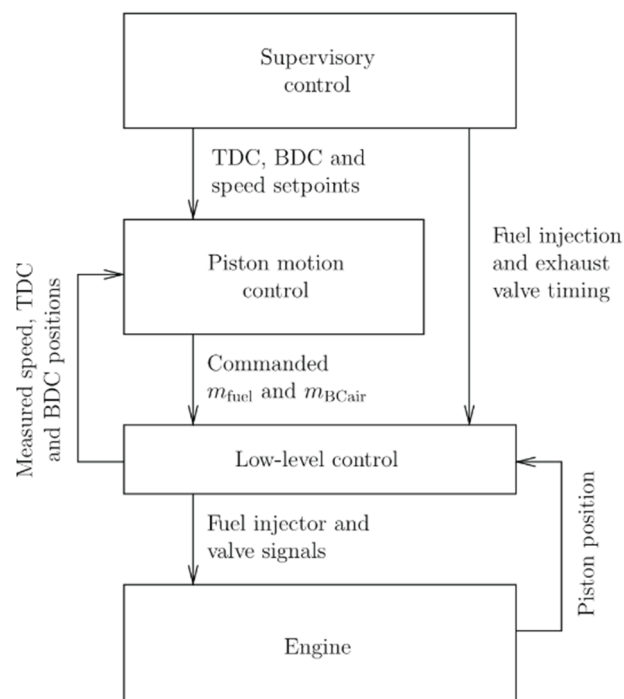

Figure 21. Free-piston engine control structure at Newcastle University [9].

In the following study, the predictive piston motion method was proposed to improve dynamic performance on the top dead center and compression ratio, as shown in Figure 22 [50]. The TDC estimator was based on the piston velocity of the nominal half-stroke point. Results from simulations showed that this control method had good control performance for free-piston engines. In this control strategy, piston motion state is used as an auxiliary variable to control the piston position. It is superior to the control methods of single position feedback. In [51,52], this control principle was developed into a cascade control strategy by B. Jia, as shown in Figure 23. The PID controllers of the outer and inner control loop were designed to adjust target velocity and injection adjustment, respectively.

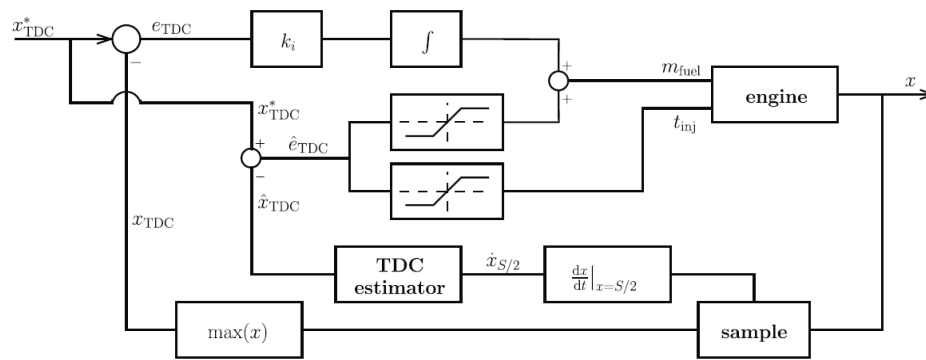

Figure 22. Free-piston engine estimation and control system at Newcastle University [44].

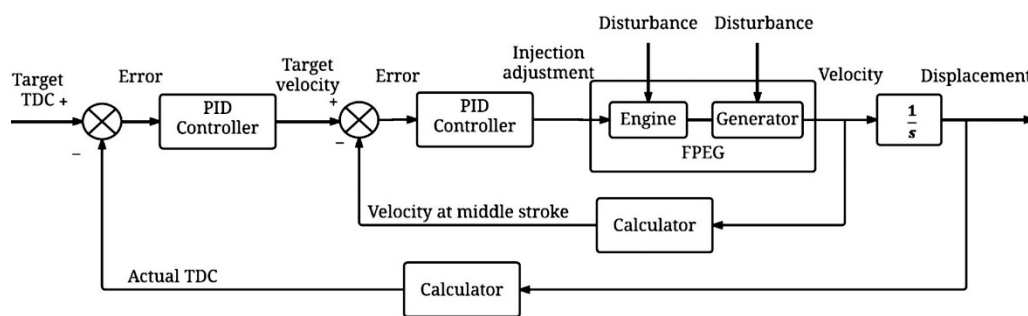

Figure 23. Block diagram FPLG coupled with cascade control [51].

In the above mentioned control methods, the load force from the LEM was assumed to be the disturbance, and the load coefficient was a constant in different cycles. The active control objects were the injected fuel mass and pressure control valves of the bounce chamber. They were directly used to control the piston motion. However, when detonation and incomplete burning happens in combustion chamber, piston position and velocity will be significantly affected, and then position errors of the dead centers will increase. Therefore, the actual control performance of piston position would be limited due to combustion fluctuations by using combustion control method.

4.2.2. Active LEM Control

For active LEM control, LEM is used to operate the piston motion state and even output power. The related control variables of combustion process are not utilized to directly control piston motion, but to change the output energy. In [53], P. Němeček presented a trajectory tracking control, in which the reference trajectory was similar to sinusoidal curves. At the same time, the combustion parameters were set to constant values, such as ignition position, fuel mass, and so on. In this approach, high-precision control was implemented on the position of dead centers, and more freedom was allowed in the piston motion after combustion. The controller avoided collision between the piston and the cylinder head and ensured the piston continuous operation of FPLG. However, due to the offline predefined trajectory, the transient behaviors were not satisfied while the combustion parameters varied.

Similarly, a reference waveform was obtained from model simulation by imitating the actual trajectory [14]. As shown in Figure 24, the feed forward gain of piston velocity was used to the feedback control loop of the piston position. This control method was able to maintain FPLG continuous operation in specified input conditions, but it was not able to control the piston swing motion as the system input power changed. In the following research, this research team designed a novel control method based on the piston maximum reference velocity, the basic principle is shown in Figure 25 [1]. The velocity of the piston motion and dead centers positions were governed. The maximum piston

velocity commands were set based on the dead center errors and the output power of FPLG. This control method can steadily control the dead center positions whether input energy increases or decreases. However, piston motion trajectory produced by this control approach may not be optimal for output power and combustion efficiency because this motion trajectory is just associated with piston maximum velocity and fuel releasing energy, but not related to the combustion parameters and state.

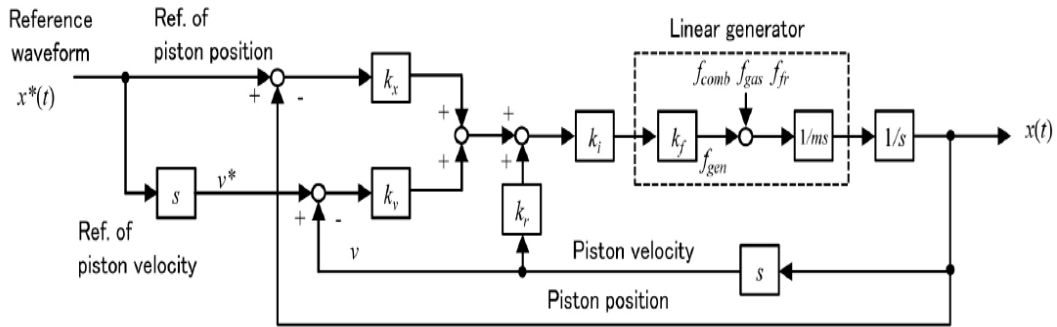

Figure 24. The control diagram of Toyota Central R&D Labs [14].

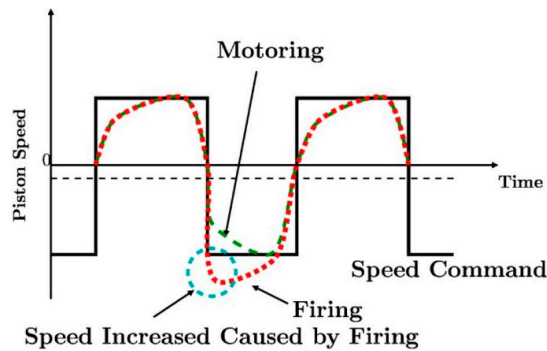

Figure 25. The basic principle diagram of the control method at Toyota Central R&D Labs [1].

In addition, as shown in Figure 26, a hierarchical hybrid controller was designed for FPLG piston motion control by H. Xia [54]. The electro-magnetic force was considered as a flexible input to control the position of dead centers. Meanwhile, the hybrid model of FPLG was built based on the valves switching and the continuous dynamics. x represents the trigger positions of the valve switching; q represents the continuous phase between different valve switching positions. In this case, the piston motion state could be monitored through the switching conditions and the trigger positions. The controller was only simulated in the simulation model, the friction force and the electro-magnetic force were regarded as constant values. However, it provided a state switching control method for FPLG.

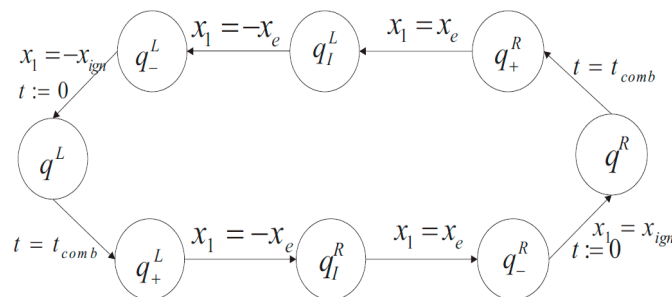

Figure 26. Hybrid automation of FPLG [54].

Similarly, in Figure 27, Z. Xu designed Hierarchical hybrid control of FPLG with a four-stroke combustion process [7,10,55]. A moving coil linear generator was implemented to drive the free piston and generates electricity [56]. In the starting stage, the constant reference electro-magnetic force was used to control the dead center positions in different strokes. In the generator model, the armature current was limited by the maximum reference electro-magnetic force. Meanwhile, considering that the control object was nonlinear, the bang-bang control method was introduced to adjust action time of the actual electro-magnetic force [57]. The control strategy was verified in the designed prototype, and could provide a good control performance at the piston motion and dead center positions. In this control method, the four-stroke operation principle of FPLG brought more cycle periods than the two-stroke to control the top dead center around the combustion process. However, the output power of the four-stroke was less than the two-stroke in the same prototype size.

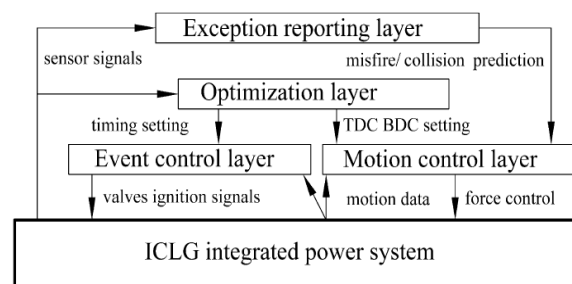

Figure 27. Hierarchical hybrid control strategy of FPLG [7].

In [37,38], considering the acceleration and deceleration characteristic of piston motion, the ladder-like reference electro-magnetic force control strategy was implemented to control piston dead centers, as shown in Figure 28. In a stroke, reference current is divided into two parts: small reference current in acceleration zone, and larger reference current in deceleration. The simulation results of different control strategies shown that it improved the system output power.

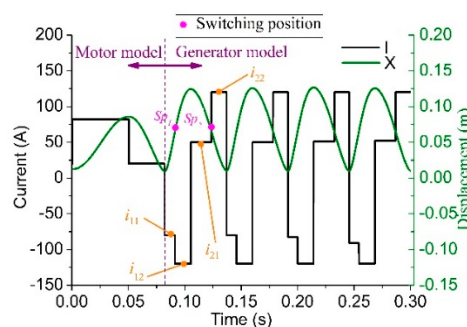

Figure 28. The principle diagram of the ladder-like electromagnetic force control strategy.

Active LEM control is a reliable and effective strategy for the piston motion control. Though some literature provides a possible optimal reference trajectory, piston motion state is not directly related to combustion indicated efficiency, LEM efficiency and system output electric power. With these control strategies, the system efficiency may not be optimal. Therefore, a promising active LEM control method of FPLG should be variable-parameters control based on the combustion performance and output specification.

4.2.3. The Mixed Control Strategy

For the mixed control strategy, LEM and combustion parameters will be used to actively control piston motion. X. Gong et al. studied nonlinear control scheme and proposed a model

predictive control (MPC) strategy of dual-cylinder FPLG [49,58–62]. The researchers built a nonlinear, discrete-time, and control-oriented model based on the energy conservation equation. In this control system, the clearance between the cylinder head and piston motion were used as a control objective. Meanwhile, the dead center positions in current cycles was estimated by Newton's method and Extended State Observer (ESO) [61]. In addition, the control variables were fuel mass and electrical load, as shown in Figure 29. Thus, with this control strategy, the clearance could be maintained in a range between hitting cylinder head and misfire. As demonstrated in simulations, the designed controller provided good performance in tracking clearance height under transient load change. Though this approach was only verified in simulation environment, the control strategy provided promising ideas combining the LEM and combustion parameters control for piston motion. It means that this control strategy connects the output and input parameters to control the piston motion.

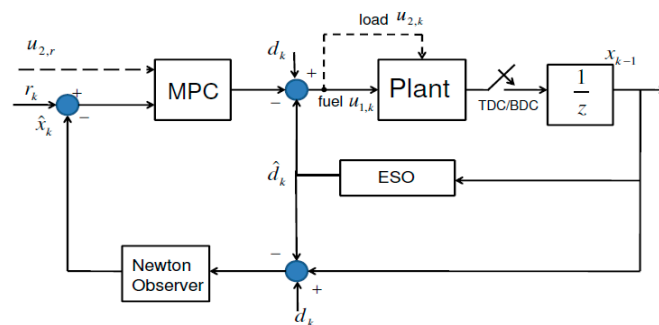

Figure 29. Control scheme of model predictive control [50].

In [5,63–65], the predefined reference trajectory named virtual crankshaft was utilized to control piston motion, and it was planned as an ellipse shape, as shown in Figure 30a. In particular, the reference trajectory of different strokes also could be adjusted according to compression and expansion processes, as shown in Figure 30b. The reference trajectory parameters also can be modified to reduce emission [65]. In this control structure, the combustion parameters and LEM currents are used as the control variables to control piston motion. As a result, according to the timely operation condition, higher indicated thermal efficiency and system efficiency could be obtained. Therefore, this variable reference trajectory can be a promising approach for the piston motion control of FPLG.

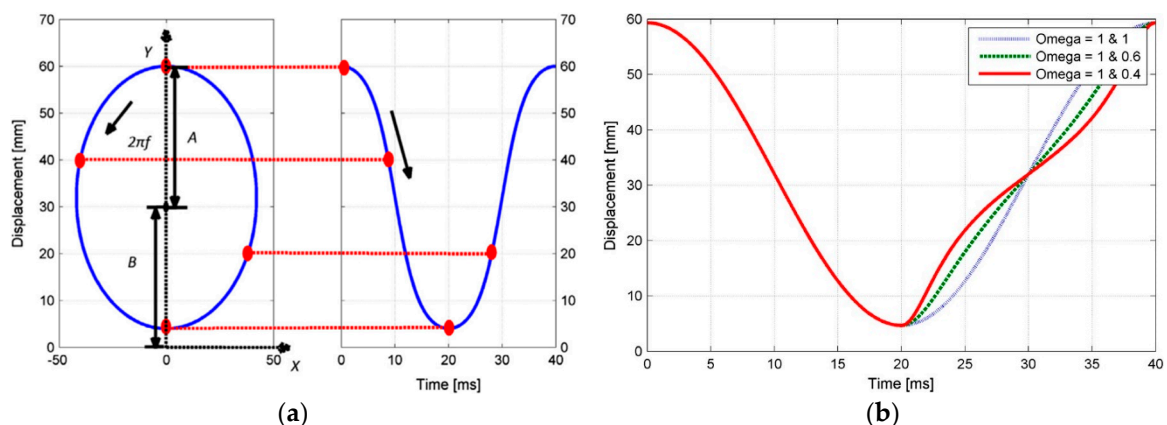

Figure 30. The basic principle diagram of reference trajectory. (a) Description of FPLG piston motions, (b) Various piston trajectories with different omega.

The mixed control strategy connects the combustion performance and system output performance. When facing different operation conditions, it has a fast response to control piston motion state, especially the dead centers. Higher system efficiency can be achieved as the desired compression ratio is guaranteed. Therefore, the mixed control strategy is an attractive control method, which is extensively researched.

5. Conclusions

The FPLG is regarded as a potential energy convertor which can extend the cruise range of hybrid electric vehicles. Therefore, it has attracted extensive research in recent years. This paper investigates different configurations of these FPLGs. The single cylinder FPLG, along with its controllable rebound device, is one of the best suitable structures for ascertaining motion characteristics in early development. The dual cylinder FPLG possesses high power density and compact size. It therefore appears to be the promising structure if the motion control difficulties can be well resolved.

In the FPLGs, LEM design and motion control are the crucial techniques to achieve high power density and stable operation with high efficiency. Permanent magnet LEMs are the most appropriate solution for the FPLG. The employment of ironless mover with Halbach PM arrays is an effective way to reduce moving mass and improve performance of dynamic response. A flat-type structure is more suitable for applications with space limitations. Moving-magnet LEMs are preferred for high power FPLG because of their high reliability compared with moving-coil type. TFPMLEMs and FSPMLEMs both can achieve high power density but suffer from low power factor and complex structure, and the combination of both PMLEMs may be a promising option which need to be further investigated.

In term of piston motion, the existing motion control methods of FPLG are classified into three main categories. When the piston motion is only directly controlled by adjusting the combustion parameters, once the combustion fluctuates, it is difficult to precisely control the piston position to achieve stable operation. On the contrary, the active LEM control is easy to guarantee the stable operation. However, if the predefined trajectory is constant, it is difficult to achieve high combustion performance due to the actual variable operating conditions. Therefore, the combination between combustion control and active LEM control is becoming an attractive scheme to satisfy the control requirements of high frequency reciprocating motion and precise compression ratio.

Author Contributions: All the authors conceived the paper and design the review study. X.Z.W. conducted the searches and analyses of the related literatures and drafted the paper; F.X. Chen and R.F.Z. collected, analyzed references and drafted the motion control and LEM design parts, respectively; C.Z. initialized the writing of this paper, structured and thoroughly revised the manuscript; G.L.Y. attended the discussions of the work and revised this paper.

Funding: This research was funded by Joint Funds of National Natural Science Foundation of China and Zhejiang Province [Grant No. U1609206], International S&T Cooperation Projects of China [Grant No. 2014DFA71010], Zhejiang Science and Technology Department [Grant No. 2018C35041], Ningbo S&T Innovation Team Project [Grant No. 2016B10016] and Key Laboratory of Robotics and Intelligent Manufacturing Equipment of Zhejiang Province.

Conflicts of Interest: The authors declare no conflict of interest.

References

1. Moriya, K.; Goto, S.; Akita, T.; Kosaka, H.; Hotta, Y.; Nakakita, K. Development of free piston engine linear generator system part3-novel control method of linear generator for to improve efficiency and stability. *SAE Tech. Pap.* **2016**. [[CrossRef](#)]
2. Heron, A.; Rinderknecht, F. Comparison of range extender technologies for battery electric vehicles. In Proceedings of the Eighth International Conference and Exhibition on Ecological Vehicles and Renewable Energies (EVER), Monte Carlo, Monaco, 27–30 March 2013; pp. 1–6.
3. Mikalsen, R.; Roskilly, A.P. A review of free-piston engine history and applications. *Appl. Therm. Eng.* **2007**, *27*, 2339–2352. [[CrossRef](#)]
4. Hung, N.B.; Lim, O. A review of free-piston linear engines. *Appl. Energy* **2016**, *178*, 78–97. [[CrossRef](#)]

5. Zhang, C.; Li, K.; Sun, Z. Modeling of piston trajectory-based hcci combustion enabled by a free piston engine. *Appl. Energy* **2015**, *139*, 313–326. [[CrossRef](#)]
6. Schneider, S.; Rinderknecht, F.; Friedrich, H.E. Design of future concepts and variants of the free piston linear generator. In Proceedings of the Eighth International Conference and Exhibition on Ecological Vehicles and Renewable Energies (EVER), Monte Carlo, Monaco, 25–27 March 2014; pp. 1–8.
7. Xu, Z.; Chang, S. Prototype testing and analysis of a novel internal combustion linear generator integrated power system. *Appl. Energy* **2010**, *87*, 1342–1348. [[CrossRef](#)]
8. Kosaka, H.; Akita, T.; Moriya, K.; Goto, S.; Hotta, Y.; Umeno, T.; Nakakita, K. Development of free piston engine linear generator system part 1—Investigation of fundamental characteristics. *SAE Tech. Pap.* **2014**. [[CrossRef](#)]
9. Mikalsen, R.; Roskilly, A.P. The control of a free-piston engine generator. Part 1: Fundamental analyses. *Appl. Energy* **2010**, *87*, 1273–1280. [[CrossRef](#)]
10. Xu, Z.; Chang, S. Hierarchical hybrid control of a four-stroke free-piston engine for electrical power generation. In Proceedings of the International Conference on Mechatronics and Automation, Changchun, China, 9–12 August 2009; pp. 4045–4049.
11. Hung, N.B.; Lim, O.; Iida, N. The effects of key parameters on the transition from si combustion to hcci combustion in a two-stroke free piston linear engine. *Appl. Energy* **2015**, *137*, 385–401. [[CrossRef](#)]
12. Ferrari, C.; Friedrich, H.E. Development of a free-piston linear generator for use in an extended-range electric vehicle. In Proceedings of the EVS26 International Battery, Hybrid and Fuel Cell Electric Vehicle Symposium, Los Angeles, CA, USA, 6–9 May 2012; pp. 6–9.
13. Mikalsen, R.; Roskilly, A.P. The control of a free-piston engine generator. Part 2: Engine dynamics and piston motion control. *Appl. Energy* **2010**, *87*, 1281–1287. [[CrossRef](#)]
14. Goto, S.; Moriya, K.; Kosaka, H.; Akita, T.; Hotta, Y.; Umeno, T.; Nakakita, K. Development of free piston engine linear generator system part 2—investigation of control system for generator. *SAE Tech. Pap.* **2014**. [[CrossRef](#)]
15. Mikalsen, R.; Roskilly, A.P. Performance simulation of a spark ignited free-piston engine generator. *Appl. Therm. Eng.* **2008**, *28*, 1726–1733. [[CrossRef](#)]
16. Zheng, P.; Zhu, S.; Yu, B.; Cheng, L.; Fan, Y. Analysis and optimization of a novel tubular staggered-tooth transverse-flux pm linear machine. *IEEE Trans. Magn.* **2015**, *51*, 1–4. [[CrossRef](#)]
17. Johnson, T.A.; Leick, M.T.; Moses, R.W. *Experimental Evaluation of the Free Piston Engine-Linear Alternator (FPLA)*; Sandia National Laboratories Press: Albuquerque, NM, USA, 2015.
18. Zhu, Y.; Wang, Y.; Zhen, X.; Guan, S.; Wang, J.; Wu, Y.; Chen, Y.; Yin, S. The control of an opposed hydraulic free piston engine. *Appl. Energy* **2014**, *126*, 213–220. [[CrossRef](#)]
19. Huang, L. An opposed-piston free-piston linear generator development for HEV. *SAE Tech. Pap.* **2012**. [[CrossRef](#)]
20. Cosic, A.; Sadarangani, C.; Leksell, M. 3D analyses of a novel transverse flux machine for a free piston energy converter, Electrical Machines. In Proceedings of the 18th International Conference on Electrical Machines, Vilamoura, Portugal, 6–9 September 2008; pp. 1–6.
21. Sun, P.; Zhang, C.; Chen, J.; Zhao, F.; Liao, Y.; Yang, G.; Chen, C. Decoupling design and verification of a free-piston linear generator. *Energies* **2016**, *9*, 1067. [[CrossRef](#)]
22. Rinderknecht, F. A highly efficient energy converter for a hybrid vehicle concept-focused on the linear generator of the next generation. In Proceedings of the 8th International Conference and Exhibition on Ecological Vehicles and Renewable Energies (EVER), Monte Carlo, Monaco, 27–30 March 2013; pp. 1–7.
23. Wang, J.; Baker, N.J. Comparison of flux switching and modulated pole linear machines for use with a free piston. In Proceedings of the IEEE International Electric Machines & Drives Conference (IEMDC), Coeur d’Alene, ID, USA, 10–13 May 2015; pp. 642–648.
24. Tang, R. *Modern Permanent Magnet Motor Theory and Design*; China Machine Press: Beijing, China, 2016.
25. Wang, J.; Howe, D.; Lin, Z. Comparative studies on linear motor topologies for reciprocating vapor compressors. In Proceedings of the IEEE International Electric Machines & Drives Conference, Antalya, Turkey, 3–5 May 2007; pp. 364–369.
26. Wang, J.; West, M.; Howe, D.; Parra, Z.D.L.; Arshad, W.M. Design and experimental verification of a linear permanent magnet generator for a free-piston energy converter. *IEEE Trans. Energy Convers.* **2007**, *22*, 299–306. [[CrossRef](#)]

27. Sun, P.; Zhang, C.; Chen, J.; Zhao, F.; Liao, Y.; Yang, G.; Chen, C. Hybrid system modeling and full cycle operation analysis of a two-stroke free-piston linear generator. *Energies* **2017**, *10*, 213. [[CrossRef](#)]
28. Zheng, P.; Tong, C.; Bai, J.; Yu, B.; Sui, Y.; Shi, W. Electromagnetic design and control strategy of an axially magnetized permanent-magnet linear alternator for free-piston stirling engines. *IEEE Trans. Ind. Appl.* **2013**, *48*, 2230–2239. [[CrossRef](#)]
29. Wang, J.; Howe, D. Tubular modular permanent-magnet machines equipped with quasi-halbach magnetized magnets-part i: Magnetic field distribution, emf, and thrust force. *IEEE Trans. Magn.* **2005**, *41*, 2470–2478. [[CrossRef](#)]
30. Yu, B.; Zheng, P.; Xu, B.; Zhang, J.; Han, L. Flux leakage analysis of transverse-flux pm linear machine. In Proceedings of the 17th International Conference on Electrical Machines and Systems (ICEMS), Hangzhou, China, 22–25 October 2014; pp. 2284–2288.
31. Baker, N.J.; Wang, J.; Atkinson, G.J. Optimization and comparison of linear transverse flux and flux switching machines. In Proceedings of the 22th International Conference on Electrical Machines (ICEM), Lausanne, Switzerland, 4–7 September 2016; pp. 2471–2477.
32. Zhao, M.; Wei, Y.; Yang, H.; Xu, M.; Han, F.; Deng, G.; Hou, D.; Zhang, P. Development and analysis of novel flux switching transverse flux permanent magnet linear machine. *IEEE Trans. Ind. Electron.* **2018**, *1*. [[CrossRef](#)]
33. Cao, R.; Cheng, M.; Mi, C.C.; Hua, W. Influence of leading design parameters on the force performance of a complementary and modular linear flux-switching permanent-magnet motor. *IEEE Trans. Ind. Electr.* **2014**, *61*, 2165–2175. [[CrossRef](#)]
34. Zheng, P.; Tong, C.; Chen, G.; Liu, R.; Sui, Y.; Shi, W.; Cheng, S. Research on the magnetic characteristic of a novel transverse-flux pm linear machine used for free-piston energy converter. *IEEE Trans. Magn.* **2011**, *47*, 1082–1085. [[CrossRef](#)]
35. Wang, J.; Howe, D. Tubular modular permanent-magnet machines equipped with quasi-halbach magnetized magnets-part ii: Armature reaction and design optimization. *IEEE Trans. Magn.* **2005**, *41*, 2479–2489. [[CrossRef](#)]
36. Li, Q.F.; Xiao, J.; Huang, Z. Flat-type permanent magnet linear alternator: A suitable device for a free piston linear alternator. *J. Zhejiang Univ.-Sci. A (Appl. Phys. Eng.)* **2009**, *10*, 345–352. [[CrossRef](#)]
37. Zhang, C.; Chen, F.; Li, L.; Xu, Z.; Liu, L.; Yang, G.; Lian, H.; Tian, Y. A free-piston linear generator control strategy for improving output power. *Energies* **2018**, *11*, 135. [[CrossRef](#)]
38. Chen, F.; Zhang, C. A novel stable control strategy of single cylinder free-piston linear generator. In Proceedings of the IEEE International Conference on Cybernetics and Intelligent Systems (CIS) and IEEE Conference on Robotics, Automation and Mechatronics (RAM), Ningbo, China, 19–21 November 2017; pp. 587–592.
39. Annen, K.D.; Stickler, D.B.; Woodroffe, J. *Miniature Internal Combustion Engine-Generator for High Energy Density Portable Power*; Aerodyne Research Inc. Press: Billerica, MA, USA, 2008.
40. Feng, H.; Song, Y.; Zuo, Z.; Shang, J.; Wang, Y.; Roskilly, A. Stable operation and electricity generating characteristics of a single-cylinder free piston engine linear generator: Simulation and experiments. *Energies* **2015**, *8*, 765–785. [[CrossRef](#)]
41. Robinson, M.C. *Analysis and Optimization of a Dual Free Piston, Spring Assisted, Linear Engine Generator*; ProQuest LLC Press, West Virginia University: West Virginia, WV, USA, 2015.
42. Zulkifli, S.A.; Karsiti, M.N.; Aziz, A.R.A. Starting of a free-piston linear engine-generator by mechanical resonance and rectangular current commutation. In Proceedings of the IEEE Vehicle Power and Propulsion Conference, Harbin, China, 3–5 September 2008; pp. 1–7.
43. Eid, A.M.; Suh, K.-Y.; Choi, K.-J.; Han, H.-D.; Lee, H.-W.; Nakaoka, M. A unique starting scheme of linear-engine tubular pm linear generator system using position feedback controlled pwm inverter. In Proceedings of the 37th IEEE Power Electronics Specialists Conference, Jeju, Korea, 18–22 June 2006; pp. 1–5.
44. Feng, H.; Guo, Y.; Song, Y.; Guo, C.; Zuo, Z. Study of the injection control strategies of a compression ignition free piston engine linear generator in a one-stroke starting process. *Energies* **2016**, *9*, 453. [[CrossRef](#)]
45. Feng, H.; Guo, C.; Jia, B.; Zuo, Z.; Guo, Y.; Roskilly, T. Research on the intermediate process of a free-piston linear generator from cold start-up to stable operation: Numerical model and experimental results. *Energy Convers. Manag.* **2016**, *122*, 153–164. [[CrossRef](#)]

46. Jia, B.; Zuo, Z.; Feng, H.; Tian, G.; Roskilly, A.P. Investigation of the starting process of free-piston engine generator by mechanical resonance. *Energy Procedia* **2014**, *61*, 572–577. [[CrossRef](#)]
47. Jia, B.; Zuo, Z.; Feng, H.; Tian, G.; Smallbone, A.; Roskilly, A.P. Effect of closed-loop controlled resonance based mechanism to start free piston engine generator: Simulation and test results. *Appl. Energy* **2016**, *164*, 532–539. [[CrossRef](#)]
48. Yuan, C.; Feng, H.; He, Y.; Xu, J. Motion characteristics and mechanisms of a resonance starting process in a free-piston diesel engine generator. *Proc. Inst. Mech. Eng. Part A J. Power Energy* **2015**, *230*, 206–218. [[CrossRef](#)]
49. Gong, X.; Zaseck, K.; Kolmanovsky, I.; Chen, H. Modeling and predictive control of free piston engine generator. In Proceedings of the American Control Conference (ACC), Chicago, IL, USA, 1–3 July 2015; pp. 4735–4740.
50. Mikalsen, R.; Jones, E.; Roskilly, A.P. Predictive piston motion control in a free-piston internal combustion engine. *Appl. Energy* **2010**, *87*, 1722–1728. [[CrossRef](#)]
51. Jia, B.; Mikalsen, R.; Smallbone, A.; Zuo, Z.; Feng, H.; Roskilly, A.P. Piston motion control of a free-piston engine generator: A new approach using cascade control. *Appl. Energy* **2016**, *179*, 1166–1175. [[CrossRef](#)]
52. Jia, B.; Smallbone, A.; Feng, H.; Tian, G.; Zuo, Z.; Roskilly, A.P. A fast response free-piston engine generator numerical model for control applications. *Appl. Energy* **2016**, *162*, 321–329. [[CrossRef](#)]
53. Němeček, P.; Vysoký, O. Control of two-stroke free-piston generator. In Proceedings of the 6th Asian Control Conference, Bali, Indonesia, 18–21 July 2006.
54. Xia, H.; Pang, Y.; Grimble, M. Hybrid modelling and control of a free-piston energy converter. In Proceedings of the IEEE International Conference on Control Applications, Munich, Germany, 4–6 October 2006; pp. 373–378.
55. Xu, Z.; Chang, S. Modelling and control of an internal combustion linear generator integrated power system. *Int. J. Model. Ident. Control* **2009**, *7*, 398–404. [[CrossRef](#)]
56. Xu, Z.; Chang, S. Improved moving coil electric machine for internal combustion linear generator. *IEEE Trans. Energy Convers.* **2010**, *25*, 281–286.
57. Xu, Z. Research on Internal Combustion-Linear Generator Intergrated Power System and Its Implementaion. Ph.D. Thesis, Nanjing University of Science & Technology, Nanjing, China, 2010.
58. Xu, F.; Chen, H.; Gong, X.; Mei, Q. Fast nonlinear model predictive control on fpga using particle swarm optimization. *IEEE Trans. Ind. Electron.* **2016**, *63*, 310–321. [[CrossRef](#)]
59. Gong, X.; Hu, Y.; Yang, R.; Chen, H. Piston motion control of free piston engine based on iterative reference governor. *Control Theor. Appl.* **2017**, *34*, 188–196.
60. Gong, X.; Zaseck, K.; Kolmanovsky, I.; Chen, H. Dual-loop control of free piston engine generator. *IFAC-PapersOnLine* **2015**, *48*, 174–180. [[CrossRef](#)]
61. Gong, X. Modeling and Optimal Control of free Piston Engine. Ph.D. Thesis, Jilin University, Jilin, China, 2016.
62. Yang, R.; Gong, X.; Hu, Y.; Chen, H. Motion control of free piston engine generator based on LQR. In Proceedings of the 34th Chinese Control Conference (CCC), Hangzhou, China, 28–30 July 2015; pp. 8091–8096.
63. Li, K.; Sadighi, A.; Sun, Z. Active motion control of a hydraulic free piston engine. *IEEE/ASME Trans. Mechatron.* **2014**, *19*, 1148–1159. [[CrossRef](#)]
64. Li, K.; Zhang, C.; Sun, Z. Precise piston trajectory control for a free piston engine. *Control. Eng. Pract.* **2015**, *34*, 30–38. [[CrossRef](#)]
65. Zhang, C.; Sun, Z. Using variable piston trajectory to reduce engine-out emissions. *Appl. Energy* **2016**, *170*, 403–414. [[CrossRef](#)]

