

Optimal Multiscale Capacity Planning in Seawater Desalination Systems

Authors:

Hassan Baaqeel, Mahmoud M. El-Halwagi

Date Submitted: 2018-07-31

Keywords: Scheduling, Optimization, process integration, multi-effect distillation, membrane distillation, desalination

Abstract:

The increasing demands for water and the dwindling resources of fresh water create a critical need for continually enhancing desalination capacities. This poses a challenge in distressed desalination network, with incessant water demand growth as the conventional approach of undertaking large expansion projects can lead to low utilization and, hence, low capital productivity. In addition to the option of retrofitting existing desalination units or installing additional grassroots units, there is an opportunity to include emerging modular desalination technologies. This paper develops the optimization framework for the capacity planning in distressed desalination networks considering the integration of conventional plants and emerging modular technologies, such as membrane distillation (MD), as a viable option for capacity expansion. The developed framework addresses the multiscale nature of the synthesis problem, as unit-specific decision variables are subject to optimization, as well as the multiperiod capacity planning of the system. A superstructure representation and optimization formulation are introduced to simultaneously optimize the staging and sizing of desalination units, as well as design and operating variables in the desalination network over a planning horizon. Additionally, a special case for multiperiod capacity planning in multiple effect distillation (MED) desalination systems is presented. An optimization approach is proposed to solve the mixed-integer nonlinear programming (MINLP) optimization problem, starting with the construction of a project-window interval, pre-optimization screening, modeling of screened configurations, intra-process design variables optimization, and finally, multiperiod flowsheet synthesis. A case study is solved to illustrate the usefulness of the proposed approach.

Record Type: Published Article

Submitted To: LAPSE (Living Archive for Process Systems Engineering)

Citation (overall record, always the latest version):

LAPSE:2018.0360

Citation (this specific file, latest version):

LAPSE:2018.0360-1

Citation (this specific file, this version):

LAPSE:2018.0360-1v1

DOI of Published Version: <https://doi.org/10.3390/pr6060068>

License: Creative Commons Attribution 4.0 International (CC BY 4.0)

Article

Optimal Multiscale Capacity Planning in Seawater Desalination Systems

Hassan Baaqeel ^{1,2}  and Mahmoud M. El-Halwagi ^{1,*}

¹ Chemical Engineering Department, Texas A&M University, College Station, TX 77843-3122, USA; hassanmb@tamu.edu

² Chemical Engineering Department, King Fahad University of Petroleum & Minerals, Dhahran 31261, Saudi Arabia

* Correspondence: el-halwagi@tamu.edu; Tel.: +1-979-845-3484

Received: 13 May 2018; Accepted: 25 May 2018; Published: 1 June 2018



Abstract: The increasing demands for water and the dwindling resources of fresh water create a critical need for continually enhancing desalination capacities. This poses a challenge in distressed desalination network, with incessant water demand growth as the conventional approach of undertaking large expansion projects can lead to low utilization and, hence, low capital productivity. In addition to the option of retrofitting existing desalination units or installing additional grassroots units, there is an opportunity to include emerging modular desalination technologies. This paper develops the optimization framework for the capacity planning in distressed desalination networks considering the integration of conventional plants and emerging modular technologies, such as membrane distillation (MD), as a viable option for capacity expansion. The developed framework addresses the multiscale nature of the synthesis problem, as unit-specific decision variables are subject to optimization, as well as the multiperiod capacity planning of the system. A superstructure representation and optimization formulation are introduced to simultaneously optimize the staging and sizing of desalination units, as well as design and operating variables in the desalination network over a planning horizon. Additionally, a special case for multiperiod capacity planning in multiple effect distillation (MED) desalination systems is presented. An optimization approach is proposed to solve the mixed-integer nonlinear programming (MINLP) optimization problem, starting with the construction of a project-window interval, pre-optimization screening, modeling of screened configurations, intra-process design variables optimization, and finally, multiperiod flowsheet synthesis. A case study is solved to illustrate the usefulness of the proposed approach.

Keywords: desalination; multi-effect distillation; membrane distillation; process integration; optimization; scheduling

1. Introduction

In arid regions of the world, thermal desalination technologies, such as multiple effect distillation (MED), are mainstream for producing desalinated water for both residential and industrial sectors. Desalination technologies, in general, and thermal desalination technologies, specifically, are generally characterized by their high capital intensity. For example, fixed cost charges in MED typically account for 40–50% of the unit cost of production, while it is 30% in RO systems. When examining the capacities of desalination projects in arid areas, such as the Gulf countries, one cannot help but notice the widespread use of large capacity desalination projects. Large desalination plants were justified in the past to cope with the booming population in the area. For example, the population growth rate in Saudi Arabia has increased incessantly from 3% in 1960 to over 6% in 1982 [1]. However, it has plateaued since then, at around 2%. Despite that, the trend of installing large desalination projects

has continued in recent years. In 2014, Saudi Arabia built one of the world's largest desalination plants, with a design capacity of 226 million imperial gallons per day (MIGD), using multistage flash (MSF) and reverse osmosis (RO) [2]. The country is expected to spend \$27 billion in the next 20 years towards desalination projects. Hence, planning for capacity expansion of desalination systems in such situations poses a great multiperiod multiscale optimization opportunity.

Large investments are typically justified by the economies of scale associated with large projects and, in some cases, additional technological and operational limitations. However, as many technological and operational limitations diminish with the maturity of desalination technologies, the design capacity of future desalination projects is primarily an economic optimization problem. The downside of large investments lies in the higher fixed operating cost associated with larger underutilized systems and lower capital productivity.

The optimization of the capacity planning problem has been widely studied from different vistas. In the field of operational research, it is studied under the problem formulation of "Time-Capacity Optimization". The essence of this field is to optimize the size of future investment, taking advantages of the economies of scale exhibited by larger investments and at the same time, minimizing cost associated with money value of time. In a temporal order, Manne [3] was among the first to develop an analytical solution for the case of constant linear demand growth with an infinite horizon in his book "Investment for Capacity Expansion". Scarato [4] and Shuhaibar [5] explored the time-capacity expansion problem using Manne's framework in urban water systems and MSF desalination systems, respectively. Both studies have contended that the cost function is flat near the optimum point. Other papers have examined the problem in other applications, such as in the planning of hydroelectric projects [6], waste treatment systems [7], and power systems [8,9]. The problem was reconstructed by Neebe and Rao [10] for discrete technology selection with fixed capacities. Several studies [11–14] in the field of PSE (e.g., process systems engineering) address the capacity planning optimization for both deterministic and stochastic problems, and at various applications and solution techniques. In water desalination network design, process synthesis techniques have been employed for the design of desalination units of a specific technology. Example research in the synthesis of reverse osmosis networks includes the work by El-Halwagi [15] and subsequent research contributions, e.g., [16,17]. Design and optimization techniques have been developed to assess several configurations of MSF systems for various criteria [18,19]. Druetta et al. [20] evaluated the detailed design of MED seawater desalination systems for the minimization of total cost, where mixed-integer nonlinear programming (MINLP) model is employed to determine the nominal optimal sizing of system's equipment. Gabriel et al. [21] used linearization techniques to achieve global solutions of the design of MED systems. Several research contributions have been made in the area of optimizing the synthesis of MD networks for various applications [22–25]. Other research has focused on the synthesis of hybrid desalination systems. Bamufleh et al. [26] developed the framework for synthesis of a MED–MD desalination system that is thermally coupled with industrial process. Al-Aboosi and El-Halwagi [27] developed an approach for the optimization of the design of RO–MED hybrid systems using a water-energy nexus approach. Huang et al. integrated multiple desalination technologies with combined heat and power in industrial and power plants [28]. Kermani et al. [29] provided a review of water-heat nexus with a meta-analysis of network features.

Notwithstanding previous research in the field, to the extent of the authors' knowledge, no optimization framework has been established for the multiscale optimization of capacity planning in water desalination systems taking into consideration mass and heat integration opportunities with emerging desalination technologies. This paper aims at developing an optimization formulation for the capacity expansion planning that systematically extracts the optimal process design over time from numerous alternatives while considering retrofit options of existing desalination units and heat and mass integration between desalination systems. It will also simultaneously optimize the intra-process design and operating variables. This work seeks to answer the following questions in the context of capacity planning of desalination systems:

- What is the optimum staging/sizing of the new desalination units that optimize the selected objective function? Which technologies should be selected for water demand satisfaction?
- What are the optimum design and operating variables (i.e., evaporator's area, top brine temperature, etc.) for the existing and newly installed desalination units over the planning horizon?
- How shall existing and new desalination units in each planning interval be integrated (i.e., mass and heat integration) for the optimization of the objective function?

2. Problem Statement

The multiscale capacity planning problem in desalination network may be stated as follows: Given is a water desalination system subject to capacity expansions within a planning horizon of N_t years. The horizon is discretized to annual counterparts, $INTERVAL = (t|t = 1, 2, \dots, N_t)$, where $t = 1$ represents the initial time of the planning horizon, satisfied by the initial desalination system. Expansion projects commence at $t = 2$. In each interval, the total water desalination capacity of the system is denoted D_t , while the water demand at a given period is denoted d_t . Desalinated water price, Pr_t , may vary in each interval.

The set $CONFIG = (i|i = 1, 2, \dots, N_i)$ of desalination configurations are considered to meet the water demand increase. Two subsets for each configuration exist. The set $INLET_i = (m|m = 1, 2, \dots, N_{m_i})$ represents the inlet nodes for i th configuration. The set $OUTLET_i = (n|n = 1, 2, \dots, N_{n_i})$ represents the outlet node for i th configuration. For example, the configuration of MED-RO desalination depicted in Figure 1a has two inlet nodes and four outlet nodes, while the one depicted in Figure 1b has one inlet node and three outlet nodes.

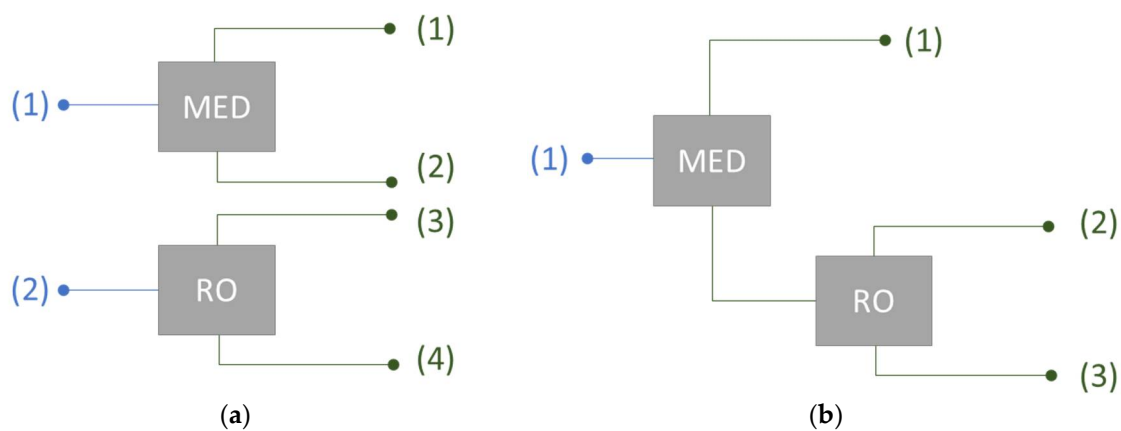

Figure 1. Example configurations for water desalination (a) with two inlet nodes and four outlet nodes, (b) with one inlet node and three outlet nodes.

The initial design of the system is fixed with a known distillate capacity of $D_t = D_1$. Due to distillate demand growth in the horizon, expansion of the desalination system is required to meet the planning horizon water demand. Saline water feed, F_t^{sw} , with a fixed salinity, x^{sw} , is available as a feedstock to new desalination units. On the overall system's level, a constraint exists on the total brine reject flowrate B_{max}^{reject} from the system, while the salinity of the system's brine and distillate are constrained by x_{max}^b and x_{max}^d , respectively.

In the context of this study, the objective is to maximize the net present value (NPV) of capital investment portfolio in the system accounting for annual revenue, fixed and operating cost, and book values. However, the formulation may be adjusted to target other objectives such as other economic, environmental, and reliability objectives. At a given minimum rate on investment (r), the objective is

to determine the optimal planning for the desalination system capacity that maximizes the total net present value (NPV) while fulfilling water-demand forecast.

Figure 1 is a schematic representation of the multiperiod capacity planning problem in a desalination system. The superstructure shows the multiperiod interactions between the potential configurations in each interval.

3. Synthesis Approach

The representation in Figure 2 typifies the synthesis approach for the system. The change in the system's distillate capacity is measured by the added capacity at each interval, ΔD_t . It is assumed that the inherited system design from a preceding interval is fixed, and changes in the system are limited to the selected configuration added at the current interval and its design variables. Nonetheless, all intervals' designs will be solved simultaneously. In each interval, all possible configurations are evaluated, each named a $SUBSYSTEM_{i,t}$. For example, the first configuration in the second interval holds the notation $SUBSYSTEM_{1,2}$.

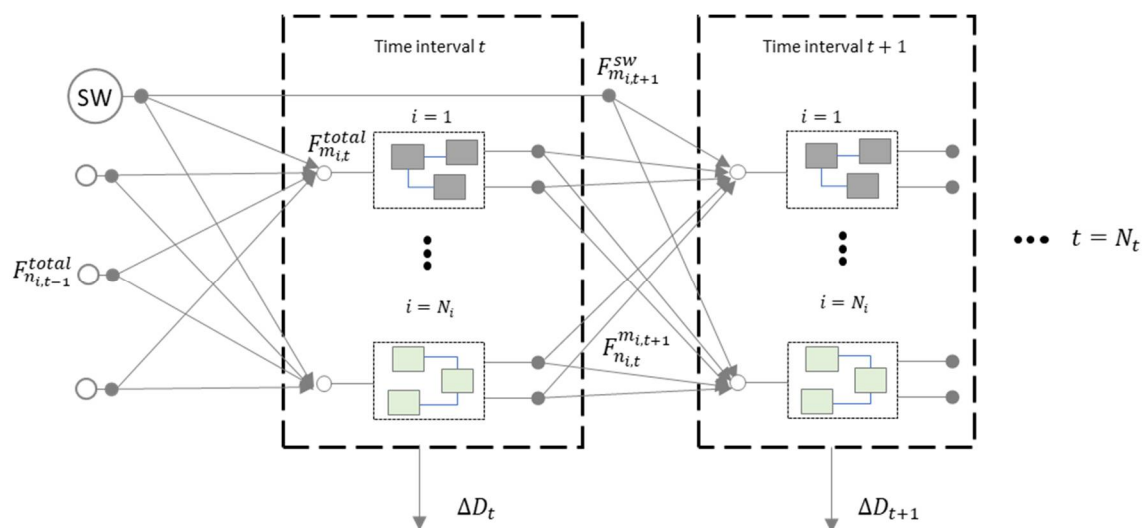

Figure 2. Multiperiod superstructure of the desalination capacity planning problem.

The multiperiod superstructure is rich enough to embed many potential designs of interest in the desalination system. For example, hybridization of desalination configurations can be done across intervals. However, the complexity of the superstructure can be prohibitive for a feasible mathematical optimization. For example, there is a total of 9,765,625 possible designs for a 10-interval horizon, and 5 five considered desalination configurations.

Our approach for a feasible optimization is shown in Figure 3. A pre-optimization screening of configurations is carried out on the system. The extensive list of desalination configurations is screened based on characteristic data of the system and knowledge on the commerciality, maturity, and economic efficacy of each configuration. In this step, unfeasible configurations, either economically or technically, based on parameters such as feed water salinity, distillate quality, range of distillate capacity, and minimum required recovery are, first, identified. The pre-optimization screening can be done in one of two ways:

- Complete elimination of configurations as a possible element of the optimal policy. This is applied on configurations with no hope of making it in the optimal flowsheet of the water system. For example, previous research and experience indicates the efficacy of RO in desalinating low- and medium-salinity water feed (i.e., brackish water) compared to MED. However, reliability and performance issues hinder its application for high-salinity water desalination. Hence,

knowledge of the feed-water quality enables the elimination of some desalination technologies and configurations. Other factors for the screening of candidate configurations are listed in Figure 3 that include, but are not limited to, their ability to achieve product quality (e.g., boron separation), meet a system constraint (e.g., brine salinity), and achieve an acceptable level of commerciality.

- Disjunction of configuration's selection based on the problem's parameters. For example, the selection between simple MED and MD desalination configurations can be modelled by a disjunctive inequality based on the targeted design capacity, Equation (1). Assuming previous knowledge of the technical and economical feasible capacity range for each configuration, the disjunction can be reformulated using common disjunctive inequality solution techniques, such as convex hull or big-M reformulation.

$$\left[\begin{array}{c} y_{MD} \\ D_{MD}^{min} \leq D_{subsystem} \leq D_{MD}^{max} \\ \vdots \end{array} \right] \vee \left[\begin{array}{c} y_{MED} \\ D_{MED}^{min} \leq D_{subsystem} \leq D_{MED}^{max} \\ \vdots \end{array} \right] \quad (1)$$

Next, key intra-process design variables are screened. Candidate design variables for the application of Bellman's principle of optimality are locally optimized within the configuration. In the cases where the design variable's optimality depends on the design capacity of the potential desalination configuration, a profile of the design variable's optimal policy with the design capacity is developed. The outputs from the disjunction, configurations' modelling, and intra-process design variables optimization are entered into the overall system optimization model. In the next section, the general formulation of the problem is presented, followed by a discussion on the special case of optimizing multiple effect distillation (MED) desalination systems.

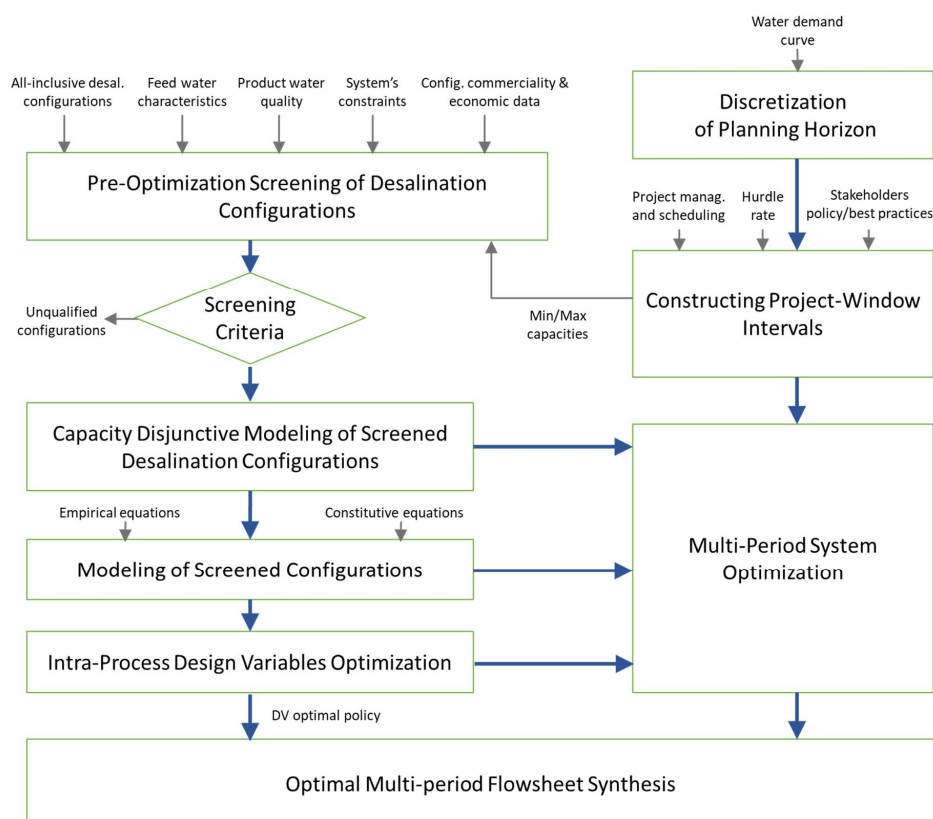

Figure 3. Optimization approach for the multiperiod capacity planning problem.

4. General Formulation

The objective function, presented later in the formulation, is subject to the following constraints:

4.1. System's Distillate Capacity

The capacity of the system shall meet or exceed water demand at any t th interval, as expressed in Equation (2), where D_t is the interval system total capacity, and d_t is the interval's water demand.

$$D_t \geq d_t \quad \forall t \quad (2)$$

The total distillate capacity can change across the multiperiod horizon. The total system's capacity at a given interval is the summation of the total distillate capacity from the previous interval and the added distillate capacity, ΔD_t , at the interval, as given by:

$$D_t = D_{t-1} + \Delta D_t \quad \forall t \quad (3)$$

The added capacity at any interval consists of the distillate capacity of the subsystems, $D_{i,t}$, installed in the interval.

$$\Delta D_t = \sum_i D_{i,t} \quad \forall t \quad (4)$$

4.2. Subsystem's Mass Balance

The mass balance on each subsystem (i.e., configuration) is given by:

$$\sum_m F_{m,i,t}^{total} - \sum_n F_{n,i,t}^{total} - D_{i,t} = 0 \quad \forall t \quad \forall i, \quad (5)$$

where $F_{m,i,t}^{total}$ is the mass flowrate to the m th inlet node of a given subsystem. The mass flowrates in all inlet nodes constitute the total inlet feed to the subsystem. Conversely, $F_{n,i,t}^{total}$ is the mass flowrate for the n th outlet node of the subsystem. The mass flowrates in all outlet nodes from all subsystems constitute the interval's brine reject, as in Equation (6), where $B_{i,t}$ and B_t are the brine flowrate of a subsystem and the interval, respectively.

$$B_{i,t} = \sum_n F_{n,i,t}^{total} \quad \forall t \quad \forall i \quad (6)$$

$$B_t = \sum_i B_{i,t} \quad \forall t \quad (7)$$

4.3. Subsystem's Inlet and Outlet Nodes

Given $F_{n,i,t}^{m,i,t+1}$ denotes the flow from n th node in $SUBSYSTEM_{i,t}$ to the m th inlet node in $SUBSYSTEM_{i,t+1}$, the split of n th outlet node is modelled as follows:

$$F_{n,i,t}^{total} = \sum_m F_{n,i,t}^{m,i,t+1} \quad \forall t \quad \forall i, \quad (8)$$

The mixing in m th inlet node in any subsystem is given by:

$$F_{m,i,t}^{total} = F_{m,i,t}^{sw} + \sum_n F_{n,i,t-1}^{m,i,t} \quad \forall t \quad \forall i, \quad (9)$$

where $F_{m,i,t}^{sw}$ is the fresh water (i.e., seawater) mass flowrate to the inlet node. Similar to Equation (3) for distillate capacity, the total seawater flowrate at any interval increases over intervals as in Equation (10).

$$F_t^{sw} = F_{t-1}^{sw} + \sum_m F_{m,i,t}^{sw} \quad \forall t \quad (10)$$

4.4. Subsystem's Modeling Equations and Constraints

Each desalination configuration is described by a distinct vector of modelling equations and constraints that characterize the performance and limitations of the subsystems employing the configuration. In addition to the design capacity and compositions, a configuration is characterized by the vectors $DV_{i,t}$ for design variables, $OV_{i,t}$ for operational variables, and $SV_{i,t}$ for state variables.

$$\phi_i(D_{i,t}, x_{i,t}^d, x_{i,t}^b, DV_{i,t}, OV_{i,t}, SV_{i,t}) = 0 \quad \forall t \quad \forall i \quad (11)$$

$$\phi_i(D_{i,t}, x_{i,t}^d, x_{i,t}^b, DV_{i,t}, OV_{i,t}, SV_{i,t}) \geq 0 \quad \forall t \quad \forall i \quad (12)$$

Key constraints for desalination configurations include the design capacity as in Equation (13), and limits on some design variables (i.e., membrane area), as in Equation (14).

$$D_i^{min} \leq D_{i,t} \leq D_i^{max} \quad \forall t \quad \forall i \quad (13)$$

$$DV_i^{min} \leq DV_{i,t} \leq DV_i^{max} \quad \forall t \quad \forall i \quad (14)$$

In some cases, the limitation on the design variable extends across intervals, for example, the maximum RO modules in series, or a constraint on the maximum number of evaporative effects in series across all intervals. Such constraints may be captured by the following:

$$\sum_t DV_{i,t} \leq DV_i^{max} \quad \forall t \quad \forall i. \quad (15)$$

One key constraint for the system, to be met in all intervals, is the salinity constraint in both the brine and distillate. The following provide the component mass balances for the system's distillate and brine, respectively:

$$x_t^d D_t = x_{t-1}^d D_{t-1} + \sum_i x_i^d \Delta D_t \quad \forall t \quad \forall i, \quad (16)$$

$$x_t^b B_t = \sum_i x_i^b B_{i,t} \quad \forall t \quad \forall i. \quad (17)$$

Given a fixed maximum salinity on the brine, x_{max}^b and the distillate x_{max}^d , the respective constraints are given by

$$x_t^b \leq x_{max}^b \quad \forall t, \quad (18)$$

$$x_t^d \leq x_{max}^d \quad \forall t. \quad (19)$$

4.5. System's Costing and Objective Function

The total capital investment of each subsystem is correlated with the design variables and design capacity. Total operating cost correlates with the actual distillate production at the interval, as well as, all design and operating variables of the constituent subsystems.

$$TCI_{i,t} = f_i^c(D_{i,t}, DV_{i,t}) \quad \forall i \quad \forall t \quad (20)$$

$$TCI_t = \sum_i TCI_{i,t} \quad \forall i \quad \forall t \quad (21)$$

$$AOC_t = f_i^o(d_t, DV_{i,t}, OV_{i,t}) \quad \forall i \quad \forall t \quad (22)$$

The proposed objective function is the maximization of the net present value (NPV) as an economic metric of the desalination system as given by Equation (23). Thus, other economic metrics, such as internal rate of return (IRR), may easily be used instead. The terms V_t , AOC_t , and TCI_t represent the revenue, annual operating cost, and total capital investment at t th interval, respectively. All cash flows are properly discounted with the underlying assumption of the cash flow's realization at the beginning of the year. A linear depreciation model with no salvage value is assumed to estimate the system's

book value, BV_t , at the end of the planning horizon. The service life, SL , is assumed constant for all units in the desalination system.

$$\text{Maximize NPV} = \sum_t \frac{REV_t - AOC_t - TCI_t}{(1+r)^{(t-2)}} - \frac{BV_t}{(1+r)^{(H-1)}} \quad \forall t \quad (23)$$

$$BV_t = TCI_t \times \text{argmax} \left(0, 1 - \frac{H - (t-1)}{SL} \right) \quad \forall t \quad (24)$$

$$REV_t = D_t \times Pr_t \quad \forall t \quad (25)$$

To model the project-window intervals stipulated in synthesis approach (e.g., Figure 2), a new constraint is introduced on the allowable intervals for plant's installation. It is unlikely for capacity expansion projects to sequence in annual or biannual basis for economic and other considerations (i.e., safety, reliability, project management, etc.). Assuming a fixed period between project windows, τ , the constraint is enforced by assuming zero added desalination capacity for potential desalination plants in between project-permissible intervals, as given by

$$\Delta D_t = 0 \quad \forall t \in \text{INTERVAL} : t \neq \tau, 2\tau, \dots, n\tau. \quad (26)$$

5. MED Special Case Formulation

Characterized by large design capacity and its capacity for integration with other desalination technologies, seawater multiple effect distillation (MED) desalination systems are good candidates for the presented optimization formulation. In this section, a shortcut method is proposed for the modelling and optimization of capacity expansion planning in MED desalination system. A set of three technologies are considered as modifications in the network to meet water demand. The conventional option is installing a new grassroots MED unit. Alternatively, existing MED units may be retrofitted with additional evaporative effects for additional water recovery or integrated with MD for brine treatment.

Next, a step-by-step application of the synthesis approach in Figure 2 on MED desalination systems for capacity expansion is carried out to develop a shortcut method for the special case.

5.1. Desalination Configuration Screening

A strategy of screening unfeasible desalination technologies and technologies that do not integrate with the existing system is adopted. MED and MD are the two technologies considered, forming three distinct configurations: new standalone MED unit, new evaporative effects to existing MED units, and MD unit for brine treatment. MD desalination of fresh seawater is eliminated based on previous techno-economic analysis and research on MD [26].

5.2. Capacity Disjunctive Modelling

In this step, the search space for the optimal flowsheet is reduced by applying the predetermined knowledge on the optimality of each screened configuration. For the retrofit configuration (EE), a capacity range, D_{EE}^{low} and D_{EE}^{high} is determined in which retrofit is part of the optimality policy. The decision is based on three distinct features of this configuration: limited distillate production, higher energy efficiency, and modest capital investment. The disjunction is expressed mathematically as follows:

$$I_{EE,t} D_{EE}^{low} \leq D_t \leq I_{EE,t} D_{EE}^{high} \quad \forall t, \quad (27)$$

$$I_{EE,t} D_{EE}^{high} \leq D_t \leq I_{EE,t} D_{MED}^{max} \quad \forall t, \quad (28)$$

where $I_{i,t}$ is a binary variable for each desalination subsystem. In the case where one configuration is allowed in each interval, the sum of the binary variables at any given interval must not exceed one.

$$\sum_i I_{i,t} \leq 1 \quad \forall t \quad \forall i \quad (29)$$

5.3. Configuration's Modeling

Various models were evaluated for use in the special formulation for the MED configuration [21,30–32]. A modified version of the MED model presented by El-Halwagi [32] is used here. The modification intends to make the model suitable for capacity expansion optimization applications, in which retrofitting the system with additional effects is considered. All the above mathematical models target a grassroots design. Hence, the implication of adding additional effects on an existing MED unit on water production, steam consumption, and capital and operating cost are not easily inferred.

For a given MED system with a variable number of effects, N_{eff} , the total MED distillate production is given by

$$D_{MED} = \sum_{n=1}^{N_{eff}} D_n, \quad (30)$$

where n is the evaporative effect number. D is the distillate water mass flowrate. The heat load of each evaporator, $Q_{evp,n}$ is estimated by the heat of vaporization, λ_n , at the temperature of the evaporator:

$$Q_{evp,n} = \lambda_n D_n. \quad (31)$$

Several types of evaporators may be used, including falling film, rising film, and forced circulation. Assuming a horizontal-tube falling film evaporator (HTFFE), the evaporator's design (i.e., area) is given by

$$Q_{evp,n} = U_{HTFFE,n} A_{HTFFE,n} \Delta T_{LM,n}. \quad (32)$$

For a conceptual design of a water system, like the one treated in this paper, the following simplifying assumptions are deemed acceptable, reducing the MED distillate capacity equation to Equation (35):

- The log-mean temperature difference may be assumed equal to the temperature difference between the vapor temperature in the tubes and the evaporator's temperature, Equation (33).
- The temperature difference between all effects are equal. Therefore, the MED temperature profile is estimated by Equation (34).
- All evaporators are identical in size.

$$\Delta T_{LM,n} = T_{n-1} - T_n \quad (33)$$

$$\Delta T_{LM,n} = \frac{(T_s - T_c)}{N_{eff} + 1} \quad (34)$$

$$D_{MED} = \frac{A_{HTFFE} (T_s - T_c)}{(N_{eff} + 1)} \sum_n^{N_{eff}} \frac{U_{HTFFE,n}}{\lambda_n} \quad (35)$$

Several correlations exist for U_{HTFFE} and λ with temperature, examples of which are presented in Equations (36) and (37). Assuming a linear correlation of both parameters with temperature, the summation term of the U/λ ratio may be correlated to three design variables: T_s , T_c , and N_{eff} . Numerical analysis of the term shows a linear correlation of the term with N_{eff} at a fixed T_s and T_c values. Therefore, Equation (35) can be rewritten as

$$U_{HTFFE,n} = 0.8552 + 0.0047 T_n, \quad (36)$$

$$\lambda_n = -2.7532 T_n + 3278.8, \quad (37)$$

$$D_{MED} = \frac{A_{HTFFE}(T_s - T_c)}{(N_{eff} + 1)} (\alpha_{MED} N_{eff}). \quad (38)$$

α_{MED} is a design parameter, estimated from the steam and cooling water temperature available at the facility. It is linearly estimated by Equation (39), where a_s and a_c are two scalar values.

$$\alpha_{MED} = \alpha_s T_s + \alpha_c T_c \quad (39)$$

Hence, Equation (35) may be rewritten as follows:

$$D_{MED} = \alpha_{MED} (T_s - T_c) \left(\frac{N_{eff}}{N_{eff} + 1} \right) A_{HTFFE}. \quad (40)$$

The new equation correlates, conveniently, the unit's total water production with the area and number of evaporative effects. Gained output ratio, GOR, is a useful estimate of the unit's thermal efficiency. It is defined by Equation (40) and empirically estimated by Equation (42).

$$M^s = \frac{D}{GOR} \quad (41)$$

$$GOR = N_{eff} (0.98)^{N_{eff}} \quad (42)$$

Combining Equations (39)–(41), the total steam consumption is given by

$$M^s = \frac{\alpha_{MED}(T_s - T_c)A_{HTFFE}}{(N_{eff} + 1)(0.98)^{N_{eff}}}. \quad (43)$$

It is reckoned that Equations (40) and (43) are very useful in modeling the second configuration, the evaporative effects retrofit (EE). Figure 4 shows the distillate capacity and steam consumption incremental change with the increase or decrease of an evaporative effect, based on the above model.

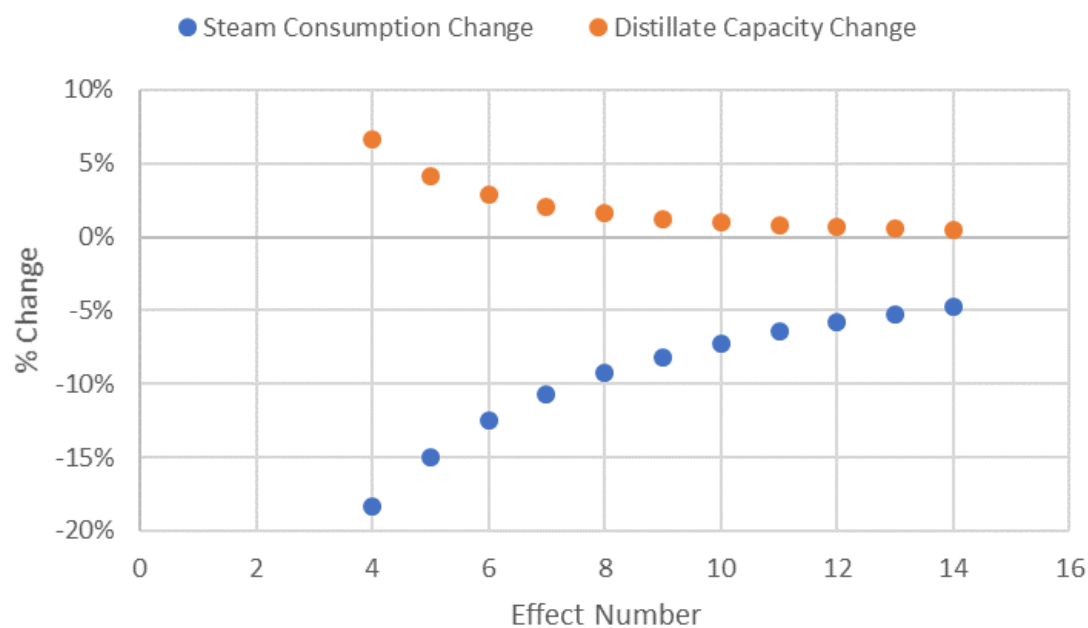

Figure 4. Net change in distillate production and steam consumption with e increase in number of evaporation effects.

5.4. Intra-Process Design Variables Optimization

In the special case, three design variables within the considered configurations are investigated: top brine temperature (TBT) in MED, number of effects in MED, and bulk feed temperature (TBF) in MD. The optimization TBT and TBF variables are associated with a tradeoff between operating and capital cost in their respective units, and have no association with the inter-process design of the system (i.e., subsystem capacity). Therefore, they are locally optimized, and inferred as a constituent of the global optimization solution.

The optimization of MED number of effects must be solved simultaneously with the multiperiod planning optimization. Alternatively, an optimal policy of the effect's number and the subsystem capacity is generated, and fed to the system multiperiod optimization.

6. Case Study

6.1. Case Study Description

The case study considers the capacity planning of an industrial water desalination system with five identical MED units, each consisting of 6 evaporative effects capable of producing 300 kg/s of distilled water. All the units are currently fully exhausted by the water demand. Due to a planned expansion in the industrial facility, water demand in a horizon of 30 years is expected to drastically increase in the next 20 years, followed by slim increases in the remaining 10 years. The demand curve is shown in Figure 5.

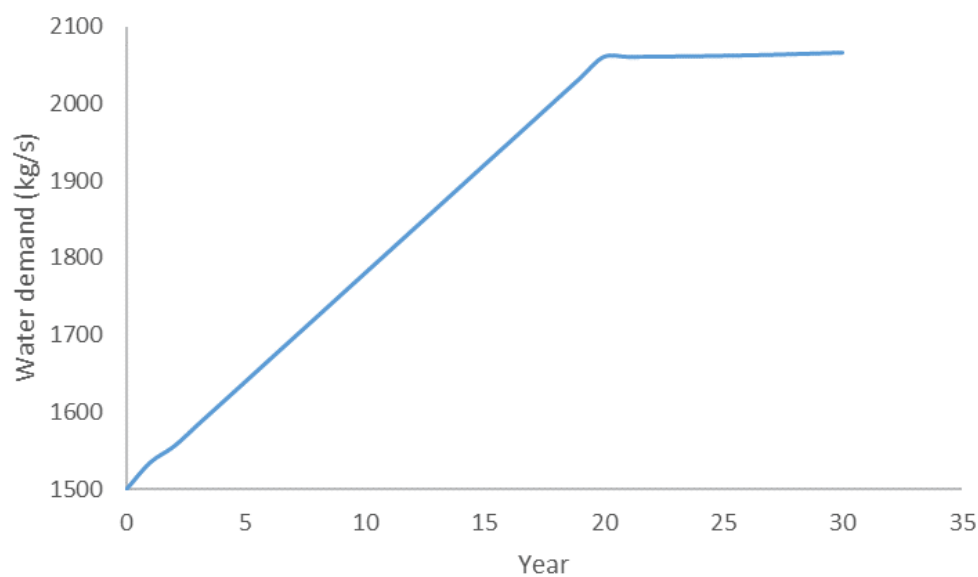

Figure 5. Water demand curve for the case study.

Seawater feed and brine parameters, as well as cost parameters, are shown in Table 2. The price of water product is fixed throughout the planning period at \$1.5 per m³. Project windows are assigned every 5 years (i.e., $\tau = 5$). Additional parameters are listed in Table 1.

For MD, a polypropylene hollow-fiber membrane MD020CP2N manufactured by Microdyn is used. The hollow fibers have a length, inner diameter, and outer diameter of 0.45 m, 1.5 mm, and 2.8 mm. Remaining details on the membrane can be found in [33]. MD design and costing model was adopted from Elsayed et al. [34]. For this case study, membrane permeability, B_w , is assumed constant at $1.92 \times 10^{-7} \frac{\text{kg}}{\text{m}^2 \cdot \text{s} \cdot \text{Pa}}$. Annualized fixed cost and annual operating cost for MD system is given by [33]

$$TCI_{MD} = 459 A_m + 13,117(1 + \gamma)F_{MD} \quad (44)$$

$$AOC_{MD} = c_{HU} \left(\frac{J_w H_{vw}}{\eta_m} \right) + (1411 + 43(1 - \zeta) + 1613(1 + \gamma)) F_{MD}, \quad (45)$$

where c_{HU} is cost of heating utility, ζ is water recovery, γ is ratio of MD recycle flowrate to feed flowrate. Design and costing equations for MED are adopted from El-Halwagi [32]. Assuming a Lang-factor of 3.5, the total capital cost is given by

$$TCI_{MED} = 24,600 N_{eff} A_{HTFFE}^{0.6}. \quad (46)$$

It is desirable to synthesize the expansion of the system for the planning horizon of 30 years, considering the three desalination configurations listed for the MED special case. The objective is to develop an optimal investment strategy to maximize net present value of the system. A minimum rate on investment for stakeholders is 15% (e.g., hurdle rate). In scenario #2, an environmentally-driven limitation of $3600 \frac{m^3}{hr}$ on the seawater mass flowrate is considered.

Table 1. Design basis for the case study.

Parameter	Symbol	Value	Unit
Seawater feed temperature	T_{sw}	298	K
Seawater salinity	x^{sw}	30,000	ppm
MED brine maximum salinity	x_{MED}^b	75,000	ppm
Steam temperature	T_s	373	K
Cooling water temperature	T_c	298	K
Steam price	c_{HU}	2.5	\$/MJ
MED minimum capacity	D_{MED}^{min}	50	kg/s
MED maximum capacity	D_{MED}^{max}	350	kg/s

6.2. Solution

The horizon was discretized to annual intervals, $N_t = 30$, with allowable expansion windows every 5 years. The optimization formulations are solved using the software LINGO® [35]. The problem is formulated as MINLP with 1337 variables, and solved on Intel Core i7-6700 CPU with 16 GB RAM in 274 s. A summary of the optimization results for all the scenarios are shown in Table 2.

Table 2. Summary of results for the case study.

	Units	Base Case	Scenario #1	Scenario #2
NPV	10^6 \$/year	−7.1	10.5	6.9
New MED Units (MED)		1	3	3
Retrofitted effects (EE)		0	1	1
Total MD area (MD)	m^2	0	0	10,800
MED top brine temperature	K	358	358	358
MD feed temperature	K	363	363	363

As a benchmark for the case study results, the results of a base case scenario of installing one MED system capable of handling the full capacity required for the planning horizon is presented.

First, two intra-process design variables are optimized locally: the TBT and TBF temperature. Within specific design limits, both involve a tradeoff between capital and operating cost. Higher top brine temperature in MED, for example, yields higher thermal efficiency, (i.e., lower specific latent heat of vaporization) and lower specific evaporative area (i.e., higher heat transfer coefficient). On the other hand, higher unit cost of steam as well as reliability and operability issues (i.e., scaling) may be incurred. The optimum TBT and TBF temperatures for all the scenarios are 358 K and 363 K, respectively. Additionally, the optimal policy for MED number of effects vs MED capacity is developed and presented in Table 3.

Table 3. Number of effects optimal policy for various MED capacities.

Number of Effects	Min. Capacity Limit (kg/s)	Max. Capacity Limit (kg/s)
6	30	55
7	55	94
8	95	150
9	151	270

Scenario #1. The optimization formulation is solved without any constraints on the seawater mass flowrate or water recovery. The solution is shown by Figure 6. Three MED units are installed in interval 1, 10, and 15. In the period of sluggish demand increase (e.g., year 20–30), retrofit of the largest MED unit with two additional effects was included in the solution. This exploits the advantage of the retrofit option: modest increase in production with positive gain in thermal efficiency.

Scenario #2: MED units are limited in water recovery by the maximum salinity in brine. Hence, with the introduction of a constraint on seawater feed, MD became a constituent of the optimal flowsheet to satisfy the required water demand with the limited fresh feed through brine treatment. MD was introduced to the flowsheet at year 15 with a total area of 10,800 m² producing a total of 54 kg/s. The total MD capital investment is estimated to be \$9.87 millions. The solution is shown by Figure 7.

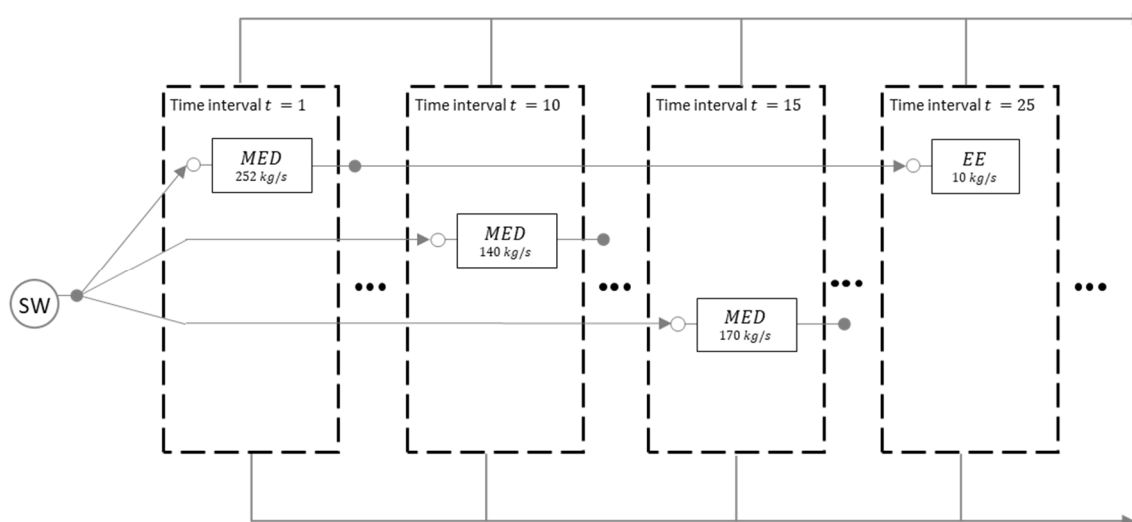
**Figure 6.** Results for Scenario #1.

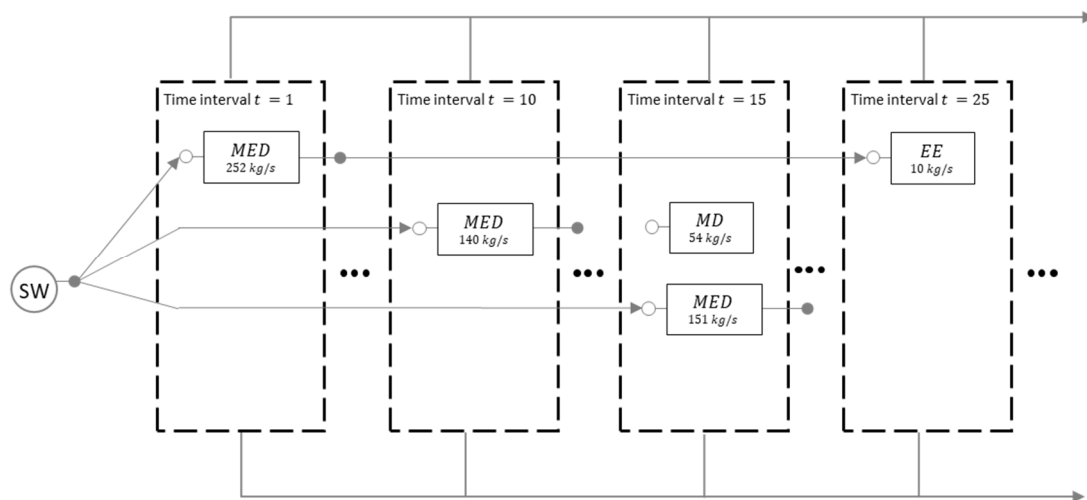

Figure 7. Results for Scenario #2.

7. Conclusions

This paper has introduced a multiperiod optimization approach for the capacity-expansion planning of water desalination systems to satisfy a forecasted demand growth over a given time horizon. The approach was illustrated in a general formulation, and in a special case for the capacity expansion in MED desalination systems, where three options were considered for capacity expansion: grassroots MED, existing MED retrofits, and MD desalination. The presented formulation simultaneously optimizes design capacities, period of installation, as well as technology-specific design variables, such as the number of MED effect, TBT, and MD feed temperature. A case study has been solved for three different scenarios to illustrate the merits of the presented approach. The results have illustrated the impact of considering alternative options for capacity expansion on the optimal design. Notwithstanding the economic challenges facing emerging technologies, alternative options to meeting demand growth, such as MD, provide advantages to the system by providing valuable flexibility and modularity in the design stage to maximize economic return.

Author Contributions: This paper is a joint collaboration between the two authors. Both authors contributed to the conception of the problem statement; solution approach; and optimization framework. H.B. carried out the computational aspects of the case study under the supervision of M.E.-H. Both authors contributed to writing and editing of the manuscript.

Conflicts of Interest: The authors declare no conflict of interest.

Nomenclature

A_{HTFFE}	area of MED evaporators, m^2
A_m	area of MD module, m^2
AOC_t	annual operating cost at t th interval
$B_{i,t}$	brine flowrate of a subsystem, kg/s
B^t	system's brine flowrate, kg/s
BV_t	end-of-horizon book value of investments at t th interval
c_{HU}	unit price of heating utility
D_t	system total distillate capacity at an interval, kg/s
$D_{i,t}$	subsystem's water capacity, kg/s
d_t	water demand at an interval, kg/s
ΔD_t	added distillate capacity at an interval, kg/s

$DV_{i,t}$	design variables of a subsystem
$F_{m,i,t}^{total}$	mass flowrate to the m th inlet node, kg/s
$F_{n,i,t}^{total}$	mass flowrate for the n th outlet node, kg/s
$F_{n,i,t}^{m,i,t}$	mass flowrate from n th outlet node to m th inlet node, kg/s
F^{sw}	seawater mass flowrate, kg/s
GOR	gained output ratio
H_{vw}	water heat of vaporization
$I_{i,t}$	binary variables for the existence of i th configuration at t th interval
J_w	water mass flux in MD, kg/(s m ²)
M^s	MED steam mass flowrate, kg/s
NPV	net present value
N_{eff}	number of evaporative effects
$OV_{i,t}$	operating variables of a subsystem
Q_{evp}	heat duty of MED evaporative effect, W
REV_t	revenue at t th interval
r	minimum rate of return
$SV_{i,t}$	state variables of a subsystem
SL	average subsystem service life
TCI_t	total capital cost of t th interval
T_s	temperature of heating steam in MED, K
T_c	temperature of cooling medium in MED, K
U_{HTFFE}	overall heat transfer coefficient of horizontal-tube falling film evaporators, W/(m ² K)
$x_{i,t}^d$	distillate salinity from a subsystem
$x_{i,t}^b$	brine salinity from a subsystem
x_i^d	overall distillate salinity of the system
x_i^b	overall brine salinity of the system
Indices	
i	index for desalination configuration
m	index for configuration's inlet node
n	index for configuration's outlet notes or number of effects
t	index for hourly time interval
Greek	
η	thermal efficiency
α	MED temperature-dependent design parameter
γ	ratio of MD recycle flowrate to fresh feed
ξ	MD water recovery
λ_n	heat of evaporation at a given MED effect, W

References

1. *Population Growth (Annual %)*; The World Bank. Available online: <https://data.worldbank.org/indicator/SP.POP.GROW?locations=SA> (accessed on 1 November 2017).
2. *Ras Al Khair Desalination Plant*; Water-Technology. Available online: <https://www.water-technology.net/projects/ras-al-khair-desalination-plant>. (accessed on 1 May 2018).
3. Manne, A.S. *Investment for Capacity Expansion*; The MIT Press: Cambridge, MA, USA, 1967.
4. Scarato, R.F. Time-capacity expansion of urban water systems. *Water Resour. Res.* **1969**, *5*, 929–936. [CrossRef]
5. Shuhaibar, Y.K. *Staging of Investment in Desalination Facilities and Associated Storage Facilities*; The University of Arizona: Tucson, AZ, USA, 1972.
6. Hreinsson, E.B. Economies of scale and optimal selection of hydroelectric projects. In Proceedings of the International Conference on Electric Utility Deregulation and Restructuring and Power Technologies (DRPT 2000), London, UK, 4–7 April 2000; pp. 284–289.
7. Rachford, T.M.; Scarato, R.F.; Tchobanoglous, G. Time-capacity expansion of waste treatment systems. *J. Sanit. Eng. Div.* **1969**, *95*, 1063–1078.

8. Billinton, R.; Karki, R. Capacity expansion of small isolated power systems using PV and wind energy. *IEEE Trans. Power Syst.* **2001**, *16*, 892–897. [[CrossRef](#)]
9. Malcolm, S.A.; Zenios, S.A. Robust optimization for power systems capacity expansion under uncertainty. *J. Oper. Res. Soc.* **1994**, *45*, 1040–1049. [[CrossRef](#)]
10. Neebe, A.M.; Rao, M.R. Sequencing capacity expansion projects in continuous time. *Manag. Sci.* **1986**, *32*, 1467–1479. [[CrossRef](#)]
11. Sahinidis, N.V.; Grossmann, I.E.; Fornari, R.E.; Chathrathi, M. Optimization model for long range planning in the chemical industry. *Comput. Chem. Eng.* **1989**, *13*, 1049–1063. [[CrossRef](#)]
12. Maravelias, C.T.; Sung, C. A projection-based method for production planning of multiproduct facilities. *AIChE J.* **2009**, *55*, 2614–2630.
13. Iyer, R.; Grossmann, I.E. Synthesis and operational planning of utility systems for multiperiod operation. *Comput. Chem. Eng.* **1998**, *22*, 979–993. [[CrossRef](#)]
14. Mitra, S.; Pinto, J.M.; Grossmann, I.E. Optimal multi-scale capacity planning for power-intensive continuous processes under time-sensitive electricity prices and demand uncertainty. Part I: Modeling. *Comput. Chem. Eng.* **2014**, *65*, 89–101. [[CrossRef](#)]
15. El-Halwagi, M.M. Synthesis of reverse-osmosis networks for waste reduction. *AIChE J.* **1992**, *38*, 1185–1198. [[CrossRef](#)]
16. Khor, C.S.; Foo, D.C.Y.; El-Halwagi, M.M.; Tan, R.R.; Shah, N. A superstructure optimization approach for membrane separation-based water regeneration network synthesis with detailed nonlinear mechanistic reverse osmosis model. *Ind. Eng. Chem. Res.* **2011**, *50*, 13444–13456. [[CrossRef](#)]
17. Vince, F.; Marechal, F.; Aoustin, E.; Bréant, P. Multi-objective optimization of RO desalination plants. *Desalination* **2008**, *222*, 96–118. [[CrossRef](#)]
18. El-Dessouky, H.; Alatiqi, I.; Ettouney, H. Process synthesis: The multi-stage flash desalination system. *Desalination* **1998**, *115*, 155–179. [[CrossRef](#)]
19. El-Halwagi, M.M. A Shortcut Approach to the Design of Once-Through Multi-Stage Flash Desalination Systems. *Desalin. Water Treat.* **2017**, *62*, 43–56. [[CrossRef](#)]
20. Druetta, P.; Aguirre, P.; Mussati, S. Minimizing the total cost of multi effect evaporation systems for seawater desalination. *Desalination* **2014**, *344*, 431–445. [[CrossRef](#)]
21. Gabriel, K.J.; Linke, P.; El-Halwagi, M.M. Optimization of multi-effect distillation process using a linear enthalpy model. *Desalination* **2015**, *365*, 261–276. [[CrossRef](#)]
22. Elsayed, N.A.; Barrufet, M.A.; El-Halwagi, M.M. An Integrated Approach for Incorporating Thermal Membrane Distillation in Treating Water in Heavy Oil Recovery using SAGD. *J. Unconv. Oil Gas Resour.* **2015**, *12*, 6–14. [[CrossRef](#)]
23. Elsayed, N.A.; Barrufet, M.A.; Eljack, F.T.; El-Halwagi, M.M. Optimal Design of Thermal Membrane Distillation Systems for the Treatment of Shale Gas Flowback Water. *Int. J. Membr. Sci. Technol.* **2015**, *2*, 1–9.
24. González-Bravo, R.; Nápoles-Rivera, F.; Ponce-Ortega, J.M.; Nyapathi, M.; Elsayed, N.A.; El-Halwagi, M.M. Synthesis of Optimal Thermal Membrane Distillation Networks. *AIChE J.* **2015**, *61*, 448–463. [[CrossRef](#)]
25. González-Bravo, R.; Elsayed, N.A.; Ponce-Ortega, J.M.; Nápoles-Rivera, F.; Serna-González, M.; El-Halwagi, M.M. Optimal Design of Thermal Membrane Distillation Systems with Heat Integration with Process Plants. *Appl. Therm. Eng.* **2014**, *75*, 154–166. [[CrossRef](#)]
26. Bamufleh, H.; Abdelhady, F.; Baaqeel, H.M.; El-Halwagi, M.M. Optimization of multi-effect distillation with brine treatment via membrane distillation and process heat integration. *Desalination* **2017**, *408*, 110–118. [[CrossRef](#)]
27. Al-Aboosi, F.Y.; El-Halwagi, M.M. An Integrated Approach to Water-Energy Nexus in Shale Gas Production. *Processes* **2018**, *6*, 52. [[CrossRef](#)]
28. Huang, X.; Luo, X.; Chen, J.; Yang, Z.; Chen, Y.; Ponce-Ortega, J.M.; El-Halwagi, M.M. Synthesis and dual-objective optimization of industrial combined heat and power plants compromising the water–energy nexus. *Appl. Energy* **2018**, *224*, 448–468. [[CrossRef](#)]
29. Kermani, M.; Kantor, I.D.; Maréchal, F. Synthesis of heat-integrated water allocation networks: A meta-analysis of solution strategies and network features. *Energies* **2018**, *11*, 1158. [[CrossRef](#)]
30. El-Dessouky, H.; Alatiqi, I.; Bingulac, S.; Ettouney, H. Steady-state analysis of the multiple effect evaporation desalination process. *Chem. Eng. Technol.* **1998**, *21*, 437–451. [[CrossRef](#)]

31. Mistry, K.H.; Antar, M.A.; Lienhard, V.J.H. An improved model for multiple effect distillation. *Desalin. Water Treat.* **2013**, *51*, 807–821. [[CrossRef](#)]
32. El-Halwagi, M.M. Water-energy nexus for thermal desalination processes. In *Sustainable Design through Process Integration: Fundamentals and Applications to Industrial Pollution Prevention, Resource Conservation, and Profitability Enhancement*; Butterworth-Heinemann: Oxford, UK, 2017; Chapter 17, pp. 441–506.
33. Al-Obaidani, S.; Curcio, E.; Macedonio, F.; di Profio, G.; Al-Hinai, H.; Drioli, E. Potential of membrane distillation in seawater desalination: Thermal efficiency, sensitivity study and cost estimation. *J. Membr. Sci.* **2008**, *323*, 85–98. [[CrossRef](#)]
34. Elsayed, N.A.; Barrufet, M.A.; El-Halwagi, M.M. Integration of thermal membrane distillation networks with processing facilities. *Ind. Eng. Chem. Res.* **2013**, *53*, 5284–5298. [[CrossRef](#)]
35. Schrage, L. *Optimization Modeling with LINGO*, 6th ed.; LINDO Systems: Chicago, UL, USA, 2006.



© 2018 by the authors. Licensee MDPI, Basel, Switzerland. This article is an open access article distributed under the terms and conditions of the Creative Commons Attribution (CC BY) license (<http://creativecommons.org/licenses/by/4.0/>).